



Crewsaver®

SERVICE MANUAL

CREWFIT 165N SPORT

LIFEJACKET

Crewsaver®

Survitec House, Lederle Lane, Gosport,
Hants. PO13 0FZ, England.
Tel: +44 (0) 1329 820000 Fax: +44 (0) 1329 236218
email: crewsaver@survitecgroup.com
Web: www.crewsaver.com

 **survitecgroup**

Service Bulletins and Amendments Register

No.	Description	Date
Issue 1	Reference to Venturi Vacuum System added (sections 6.1.2, 8.1.2 and Parts List) Back pressure test added	Nov. 2016

Scope

This manual covers primarily the servicing of the Crewfit 165N Sport Lifejacket.

Index

Section 1	1.1	Introduction
	1.2	Product Description
	1.3	Data Sheet
	1.4	General Features
	1.5	Donning Instructions
Section 2	2.1	Service Station Guidelines
	2.2	On Receipt Inspection
	2.3	General Care
	2.4	Servicing Tools
	2.5	Lifejacket Servicing Record Sheet
Section 3	3.1	Unpacking the Lifejacket
Section 4	4.1	Cleaning Lifejackets
Section 5	5.1	Inspection
Section 6	6.1	Testing
Section 7	7.1	Repairs
Section 8	8.1	Assembly
Section 9	9.1	Replacement Parts

1.1 Introduction

- 1.1.1. This Service Manual will be published on the Crewsaver website (www.crewsaver.com). Click on PARTNER /LOGIN at the top of the screen. Personnel who have been trained in the servicing procedures for this lifejacket will be issued with a Username and Password to enable them to access the download section. Each manual carries an Issue Number and records of issue are logged by Crewsaver to ensure that the service network maintains correct and up to date servicing information. Emails will be sent regarding any new Issues. Periodically service bulletins may be issued which will be published on the Crewsaver website (www.crewsaver.com). Emails will also be sent. It is the service station's responsibility to regularly check the website for any new bulletins and to ensure inclusion within the servicing manual. The service bulletin register at the front of the Manual should be completed.
- 1.1.2. The information referenced in each section follows a standard servicing procedure by which the inspection should take place.
- 1.1.3. This servicing manual details information to enable regular maintenance and servicing of the lifejacket to help prolong the life of the product and ensure it functions correctly.
- 1.1.4. The manual should be used as a reference document following training in servicing procedures instructed by Crewsaver approved personnel. The manual also details the equipment and parts needed for correct maintenance to be performed.
- 1.1.5. Servicing must be carried out annually at a service station authorised by the manufacturer. 
- 1.1.6. Regular servicing is to be carried out by qualified personnel trained by Crewsaver and holding a valid servicing certificate. Certificates are valid for a period of 3 years.

1.2 Product Description

- 1.2.1. The Crewfit 165N Sport is a single chamber 150N inflatable lifejacket.
- 1.2.2. The lifejacket is ISO approved to 12402-3.
- 1.2.3. The lifejacket is easy to don.
- 1.2.4. The buoyancy of the jacket is provided by a single chamber with an oral tube to ensure the full buoyancy can be achieved upon or after inflation.
- 1.2.5. This lifejacket is inflated either manually or by automatic firing mechanisms.
- 1.2.6. This lifejacket comes in two different versions, the waist belt version and integral deck safety harness version. The harness version, approved to ISO 12401, is fitted with a soft loop in place of the usual stainless steel D-ring.
- 1.2.7. The outer cover is made from a hard wearing material and is fastened by zip. The colour of the outer cover is normally red, blue or navy blue.

1.3 Data Sheet

Features:	Crewfit 165N Sport Lifejacket
Chamber Buoyancy:	165N
Buoyancy Category:	150N
Cover Colour	Red, Blue or Navy Blue
MCA (UK) Approved	-
SOLAS Approved	-
ISO Approved	X
Cylinder size	33g
UML Mk5 Automatic Head	According to
HR 840 Manual Head	customer choice
Manual Override	X
Oral inflation tubes	X
Pressure relief valves	N/A
Hard wearing cover	X
Whistle - fitted	X
Retro-reflective tape	X
Lifting Becket - fitted	X
Light	Optional
Spray Hood	Optional
Thigh straps - fitted *	X
Fall Arrest Harness	N/A
Closure method	Quick burst Zip
* Optional for Australia	

1.4 General Features - Crewfit 165 Sport

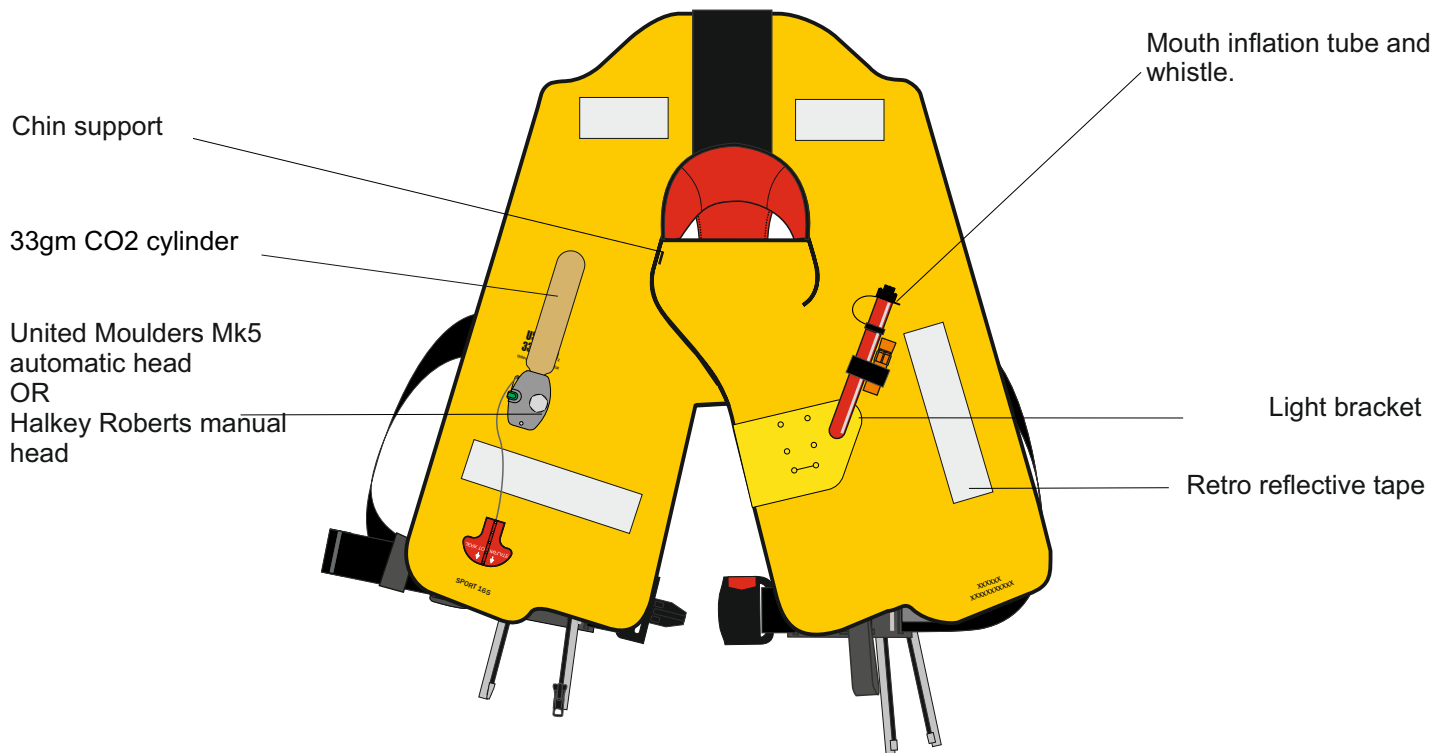

1.5 Donning Instructions - Crewfit 165 Sport

- 1 & 2 Don like a normal jacket
- 3 Fasten front buckle
- 4 Adjust waist belt by pulling side webbing backwards for a close secure fit
- 5 Fasten crotch strap* buckle and adjust straps by pulling webbing downwards for a close secure fit.

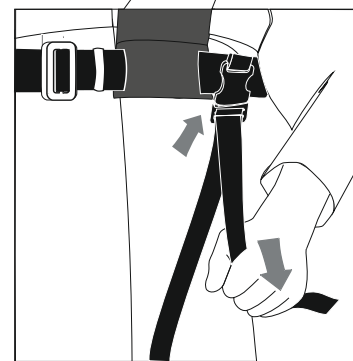
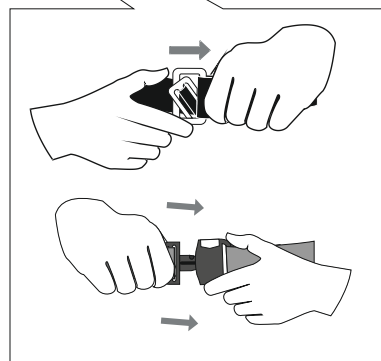
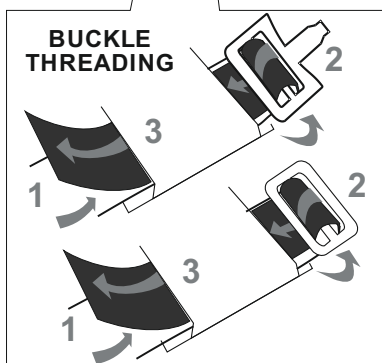
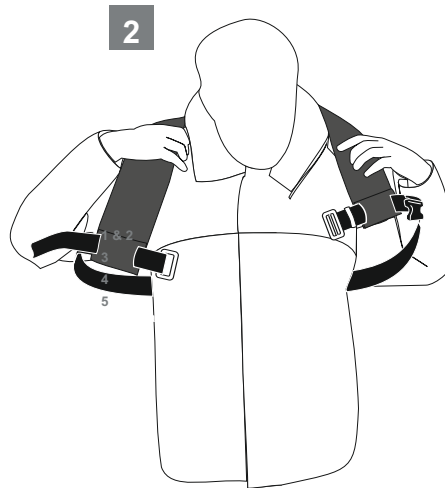
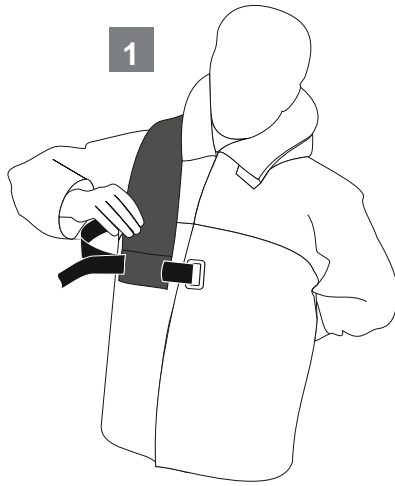

* Purchased as an optional extra on lifejackets sold into Australia

2.1 Service Stations

- 2.1.1 Service stations shall comply with the following as a minimum;
 - 2.1.1.1 Servicing of Inflatable Lifejackets shall be carried out in a fully enclosed area only.
 - 2.1.1.2 The area shall be well lit and protected from direct sunlight.
 - 2.1.1.3 The temperature and humidity shall be sufficiently controlled to ensure that the servicing of inflatable Lifejackets may be carried out successfully.
 - 2.1.1.4 The area shall be efficiently ventilated but free from draught.
 - 2.1.1.5 Sufficient tools (including specialist tools) shall be available to ensure Lifejackets may be disassembled, tested and reassembled in accordance with this Manual. These shall include but not limited to:
 - 2.1.1.5.1 Manometers and pressure gauges.
 - 2.1.1.5.2 Oil free and dry air supply.
 - 2.1.1.5.3 Scales for weighing Gas Cylinders.
 - 2.1.1.5.4 Crewsaver Service tool kit (See 2.6). This is recommended but similar calibrated devices may also be used.
 - 2.1.1.6 Stock of materials and components to allow efficient servicing with readily available replacement parts to ensure a prompt service for the customer.
 - 2.1.1.7 Only personnel trained and certified in accordance with Crewsaver requirements are approved to carry out Servicing and Maintenance. They must be holders of a valid Certificate issued by Crewsaver.
 - 2.1.1.8 The service station shall be of an approved standard.
 - 2.1.1.9 Procedures shall be introduced to ensure that service bulletins, Manuals and replacement parts are obtained from Crewsaver.
 - 2.1.1.10 Subsequent to initial approval and thereafter the service station shall be subject to regular surveillance by Crewsaver.
 - 2.1.1.11 The service station must comply with and have met all QA criteria in the Crewsaver servicing protocol file.

2.2 On Receipt Inspection

- 2.2.1 On receipt of the Lifejacket(s), check the state of the packaging before opening and notify the owner and the company delivering the package of any defects or damage.
- 2.2.2 On opening the package, check the contents for their general condition and quantity.
- 2.2.3 Prepare Servicing Record Sheet.
- 2.2.4 Visually inspect the cover and inflation chamber for damage, abrasion, contamination etc. In accordance with this manual.
- 2.2.5 Note repairs or replacements required on the record sheet.
- 2.2.6 Unless obvious damage is evident, test the Lifejacket in accordance with Section 6. If it is considered that the damage found would cause the Lifejacket to fail the tests then corrective action shall be carried out prior to testing.
- 2.2.7 Damaged areas shall only be marked using wax based crayon. Marks shall be with a small circle or cross. Ballpoint, rollerball or other forms of ink shall not be used. If in doubt refer to Crewsaver for guidance.
- 2.2.8 Repairs to welded components including the inflation chamber are expressly forbidden.

2.3 General Care

- 2.3.1 The Lifejacket should be stowed in accordance with the manufacturer's instructions.
 - 2.3.1.1 Lifejackets should be stowed in a dry compartment. Avoid high humidity, such as a car boot.
 - 2.3.1.2 Automatic Lifejackets should have stowage facilities which are provided with a method to encourage moisture removal.
 - 2.3.1.3 Lifejackets should be stowed vertically, for example hung on hooks, in order that any trapped water or condensation can drain away naturally.
 - 2.3.1.4 Lifejackets should be rinsed in fresh water and dried thoroughly after use.

WARNING

Prior to sponging or washing remove automatic capsules from the firing mechanism. Allow to dry thoroughly afterwards.

- 2.3.2 Contaminants such as oil or diesel fuel may be sponged off immediately with clean water and allowed to dry naturally.
- 2.3.3 Mud can be removed with a stiff (not wire) brush when dry.
- 2.3.4 The outer cover may be hand washed in good quality mild detergent in cool water (40°C). Rinse well, drip dry naturally in air.
- 2.3.5 Sponge the inflation chamber with pure soap solution only. Rinse in clean water immediately, inflate and allow to dry naturally in air.

WARNING

Do not use proprietary cleaning fluids, thinners, spirits or similar substances.

- 2.3.6 In cases of severe contamination the unit shall be deemed beyond economic repair and the customer advised to purchase a replacement lifejacket.

2.4 Lifejacket Servicing Tools

Fig. 2.4 Table of Tools Required

Description	Type
Crewsaver Servicing Tool Kit A fine screw driver or tool suitable for removing gaskets Boning tool Roller Brushes Scissors or good quality trimming shears “Chinagraph” pencil Tailors chalk Fine point indelible pen 1 off metal calibrated metre stick Scales to weigh gas cylinders Adaptor/tee piece for testing inflation chambers. Manometer Timing Device Thermometer Crewsaver Vemnturi Vacuum System Clean and dry air supply 1 off ball pein hammer 450mm wide bag sealer (3mm element) Back pressure test unit	0-1000gram (+1/-1 grams) 0-500Mbar 0-40°C

Suitable large surface area for the work to be carried out
 1 off FR steel cabinet (adhesive store)
 1 off HD industrial sewing machine (e.g. Singer 96K, Juki, Durkopp etc.)

N.B. In case of difficulty contact Crewsaver direct (Not sewing machines, cabinets or tables - these parts may be sourced locally.)

Note: Prior consent to carry out any repairs must be pre-approved by Crewsaver. All repairs to stitching must be in accordance with this manual.

2.5 Lifejacket Service Record Sheet

- 2.5.1. An electronic copy of the sheet is available to aid reproduction (or copy next page).
- 2.5.2. Each lifejacket serviced should be recorded either individually or as a batch, showing the serial numbers and the work performed during the service.
- 2.5.3. The service record sheet should be signed and a copy given to the owner certifying that the lifejacket has been serviced.
- 2.5.4. All replacement parts should be noted - recording either the serial numbers of the component or the expiry date.
- 2.5.5. The record sheet shown on the next page is a recommended version. Similar record sheets, including the same information, may also be used.



CERTIFICATE NUMBER:

LIFEJACKET SERVICING SCHEDULE

W/O Number:

TYPE	
CUSTOMER	
VESSEL	
LAST SERVICED BY	DATE OF LAST SERVICE

SERIAL NUMBER/S:

CHAMBER INSPECTION	<input type="checkbox"/> <input type="checkbox"/>	COMMENTS
GENERAL CONDITION		
MATERIAL		
WELDS		
WEBBINGS		
RETRO TAPE		
WHISTLE		
ORAL TUBES		
RELIEF VALVES		
MANIFOLDS		
SCHRAEDER VALVES		
CYLINDERS		
LIGHT		
CYALUME POCKET		
BUDDY LINE		

INFLATION MECHANISM	<input type="checkbox"/> <input type="checkbox"/>	COMMENTS
OPERATING MECHANISM		
CORD		
AUTOMATIC CAPSULE		
WASHERS		
RETAINING NUT		
RETAINING CLIP		
TOGGLE		

SPRAY HOOD	<input type="checkbox"/> <input type="checkbox"/>	COMMENTS
FABRIC		
ATTACHMENT		
VELCRO		

WEBBINGS	<input type="checkbox"/> <input type="checkbox"/>	COMMENTS
WAIST BELT / HARNESS		
BACK STRAP		
LIFTING BECKET		
CROTCH STRAP		
BUCKLES		
STITCHING		

COVER	<input type="checkbox"/> <input type="checkbox"/>	COMMENTS
MATERIAL		
VELCRO		
ZIP		
PLB POCKETS		

PRESSURE TEST RESULTS

TIME	FRONT CHAMBER	REAR CHAMBER
ON		
OFF		
TEMP.	ON	OFF

RELIEF VALVE TEST RESULTS

	FRONT CHAMBER	REAR CHAMBER
OPEN		
CLOSE		

REPAIRED ITEMS (COMMENTS)

SERVICED BY:

DATE:

2.6 Lifejacket Servicing Tool Kit

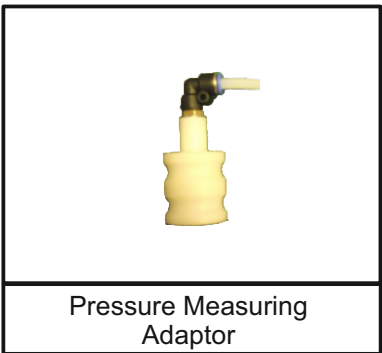
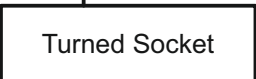
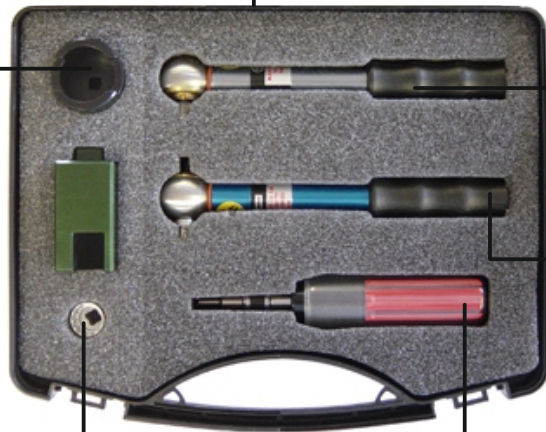
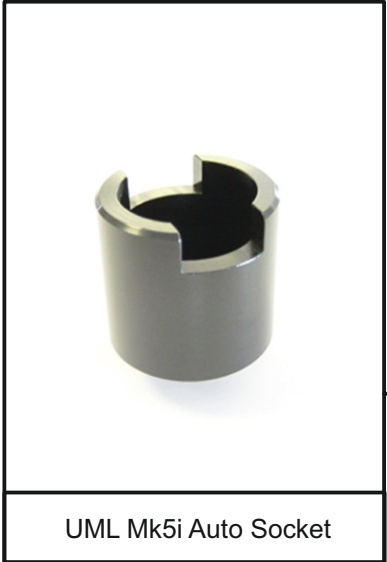

3.1 Unpacking

- 3.1.1 Open the velcro tab. To avoid damaging the lifejacket zip, pull apart the zip, and open the zip via the quick burst elements, holding the cover on either side.
Once the zip has opened insert the a finger and slide it around the outside of the lifejacket. The lifejacket cover should now be open and the inflation chamber visible. Both sides of the zip should be apart with the zip slider free to move back around the lifejacket to the start.

WARNING: All defects should be noted onto the service record sheet.

- 3.1.2 Remove the operating mechanisms.

- 3.1.2.1 Following unpacking refer to Fig 3.2 - UML Mk5 Operating Head or Fig 3.3 - Halkey Roberts Manual Operating Head.

- 3.1.2.1.1 Automatic Only. Unscrew the Automatic Capsule if fitted from the operating mechanism. Place to one side for testing and reassembly later. See Section 6 for details.
- 3.1.2.1.2 Carefully remove the inflation cylinder by unscrewing it from the operating mechanism. Retain for further Inspection. Refer to Section 5.
- 3.1.2.1.3 Remove Operating Mechanisms by unscrewing the retaining nut on the top of the inflation mechanism. Retain for further Inspection. Refer to Section 5.

- 3.1.3. Remove light if fitted. Place to one side for further inspection. Refer to section 5.
- 3.1.4. For Cleaning. Refer to Section 4.
- 3.1.5. Carry out visual inspection. Refer to section 5.

Fig 3.2 UML Mk5 Operating Head

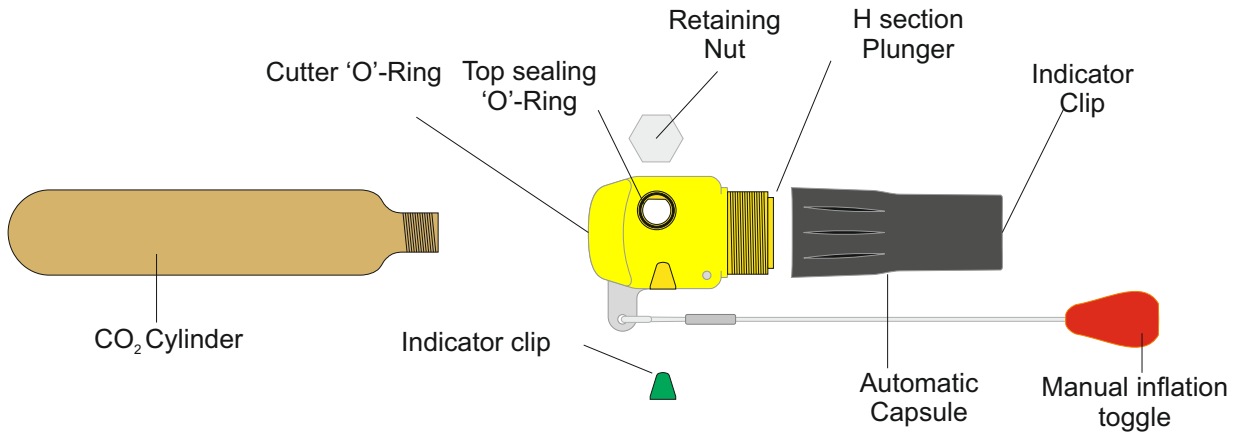

- 1 Unscrew the Automatic firing capsule from the end of the operating head. This should only be done after the test detailed in Section 6 has been performed in order to test the old unit, or if the operating head has already been fired. Discard and replace with a new automatic firing capsule upon reassembly. The Capsule must be replaced if it expires before the date of the next annual service.
- 2 Unscrew the CO₂ cylinder from the operating head. Once the cylinder has been removed inspect the Cutter O-Ring . Check the 'O' Ring is in place and that it is in a good condition. Take the cylinder and check to see if the cylinder has been used. This should be performed by check weighing. If under the minimum weight as displayed on the cylinder body, discard in a safe manner.
- 3 Unscrew the retaining nut from the top of the firing head, using 9/16" socket or spanner. Check for corrosion and discard if corroded. Inspect the top sealing O-ring. This must be replaced with a new part if damaged.
- 4 Remove the operating head from the manifold which is welded to the inflation chamber fabric. Inspect the bottom sealing O-ring. This must be replaced with a new part if damaged.
- 5 Check the pull cord and toggle for fraying or damage.

Fig 3.3 Halkey Roberts Manual Operating Head

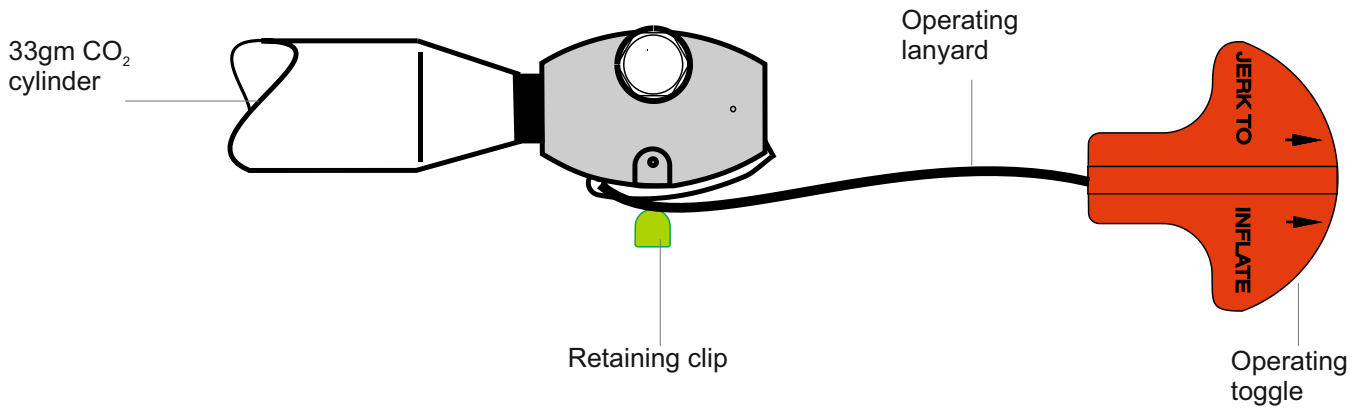

- 1 Unscrew the CO₂ cylinder from the operating head. Once the cylinder has been removed inspect the cylinder sealing washer . Check the washer is in place and that it is in a good condition. Take the cylinder and check to see if the cylinder has been used. This should be performed by check weighing. If under the minimum weight as displayed on the cylinder body, discard in a safe manner.
- 2 Unscrew the retaining nut from the top of the firing head, using 9/16" socket or spanner. Check for corrosion and discard if corroded. Remove and discard the top sealing washer. This must be replaced with a new part.
- 3 Remove the operating head from the manifold which is welded to the inflation chamber fabric. Remove and discard the bottom sealing washer. This must be replaced with a new part.
- 4 Check the pull cord and toggle for fraying or damage.

4.1 Cleaning Lifejackets

- 4.1.1 The current standard cover of the Crewfit 165 Sport is made from a 300d polyester fabric with a polyurethane coating that can be cleaned with care.
- 4.1.2 For all types of cover, mud can be removed with clean water and can be cleaned with a stiff (not wire) brush when dry.
 - 4.1.2.1 Contaminants such as oil or diesel fuel may be sponged off immediately with clean water and allowed to dry naturally.
 - 4.1.2.2 Mud can be removed with a stiff (not wire) brush when dry.
 - 4.1.2.3 Covers may be hand washed in good quality mild detergent in cool water (40°C). Rinse well, air drip dry.
- 4.1.3 Sponge the inflation chamber with PURE SOAP SOLUTION ONLY. Rinse in clean water immediately, inflate and air dry.

WARNING: Do not use proprietary cleaning fluids, thinners, spirits or similar substances.

5.1 Outer Cover Inspection

- 5.1.1 Visually inspect the cover material for wear, abrasion, pulled threads, contamination, cuts and holes.
- 5.1.2 If necessary the cover may be washed. Refer to Section 4.

NOTE: Due to the construction of this lifejacket no individual cover is available for replacement, therefore the lifejacket as a whole must be replaced.

5.2 Inflation Chamber Inspection

- 5.2.1 Visually inspect the inflation chamber material for wear, pulled threads, contamination or signs of mistreatment.
- 5.2.2 Visually inspect all welds.
- 5.2.3 Visually inspect all webbings in accordance with Section 5.6
- 5.2.4 Visually inspect the whistle and its attachment to the lifejacket for mistreatment, defects, and fraying of the cord and its attachment.
- 5.2.5 Test Lifejacket in accordance with Section 6.

5.3 Gas Cylinders

- 5.3.1 Visually examine:
 - 5.3.1.1. For Corrosion (All cylinders corroded with red rust or with visible pitting must be replaced).
 - 5.3.1.2. Pierced or damaged piercing disc.
 - 5.3.1.3. That the cylinder has the correct gas charge - 33 grams CO₂.
- 5.3.2 Check Min Weight of Cylinder against that marked on the barrel.

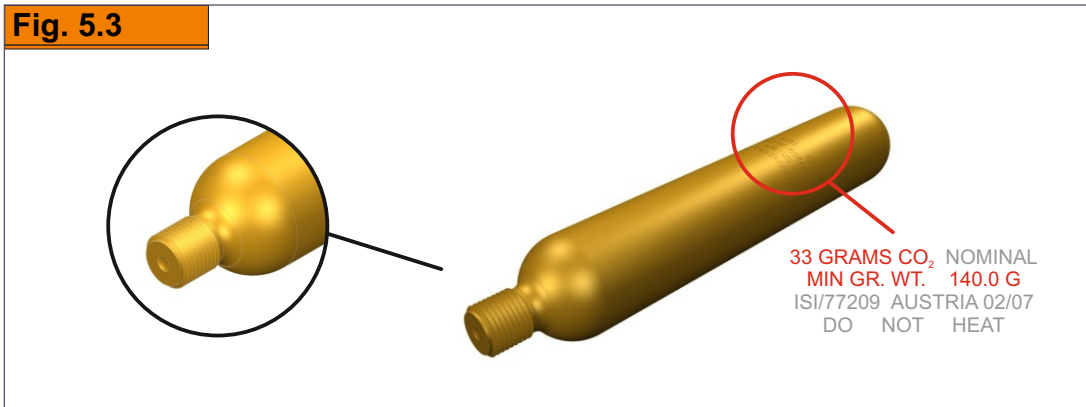

Remedial Action: If any of the above conditions are found to be incorrect the cylinder shall be replaced. See Section 9.

5.4 Mouth Inflation Valve

- 5.4.1 Visually inspect for damage.
- 5.4.2 Test in accordance with Section 6.

Remedial Action: These items are not repairable. Refer to Section 9 for replacement part.

5.5 Inflation System

- 5.5.1 Visually inspect the Operation of the Manual or Automatic Mechanism for:
 - 5.5.1.1 Operation of the Manual override lever. This shall move easily and freely.
 - 5.5.1.2 Operation of the firing pin cam action. Similarly this shall be a smooth action when the lever is operated.
 - 5.5.1.3 Firing Pin centre discharge hole clear.
 - 5.5.1.4 Activation cord for frays and damage.
 - 5.5.1.5 Moulded body for cracks and damage. Special attention to be given to the areas around the operating lever/body connection pin.
 - 5.5.1.6 Check the Automatic plunger (Automatic Head Only) at the base of the unit when depressed moves the firing pin and that the plunger and the firing pin return to their original positions when released.

- 5.5.2 Visually inspect the Operation of the Automatic Capsule on the automatic Operating Head:
 - 5.5.2.1 Check plug is in place at the base of the capsule.
 - 5.5.2.2 New Capsules are to be fitted where the expiry date is before the next annual service of the lifejacket. Capsules are marked with the month and year of expiry.
 - 5.5.2.2.1 If the capsule is to be replaced – Re-fit the old capsule and carry out operational tests. Refer to section 6.

Remedial Action: In the event that the Operating Mechanism fails any of the above inspection procedures, the complete unit shall be replaced. No Repairs are allowed. Refer to Section 9 for the part number of the relevant replacement part.

5.6 Webbings

- 5.6.1 Visually inspect for damage:
 - 5.6.1.1. Fraying
 - 5.6.1.2. Pulled Threads
 - 5.6.1.3. Broken Stitches

Remedial Action: No repairs are allowed. In the case of damage being found, return the Lifejacket to Crewsaver.

5.7 Buckles

- 5.7.1 Visually inspect all buckles used on the webbings for signs of damage or corrosion.

Remedial Action: No repairs are allowed. In the case of damage being found, return the Lifejacket to Crewsaver.

5.8 Labelling/Markings

- 5.8.1. Check all Markings and Labelling are clear and legible.

Remedial Action: No repairs are allowed. In the case of damage being found, return the Lifejacket to Crewsaver.

5.9 Lights (if fitted)

- 5.9.1 The Crewfit 165 Sport can be fitted with the Crewsaver CSL Water Activated Light.

Visually inspect the light for signs of damage to:

- 5.9.1.1. The switch.
- 5.9.1.2. the cable.
- 5.9.1.3. the lens and its mounting or housing.

- 5.9.2 Check the expiry date. The expiry date must exceed the date of the next annual service. If the light has expired or expires before the next service then it must be replaced. (See Section 9).

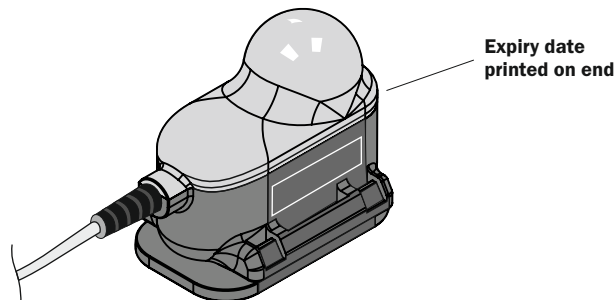

- 5.9.3 Ensure that the switch is in the Auto-on position.

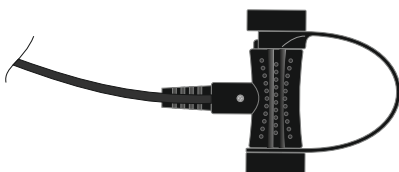

Water activated switch in Auto-on position

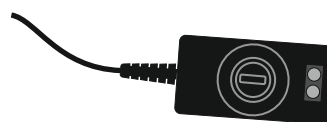

Water activated switch in Auto-on position (Later models)

- 5.9.4 Test the assembly as detailed in Section 6

6.1 Inflation Chamber

6.1.1. Air Holding Test.

6.1.1.1 Connect through a suitable Tee piece and adaptor, the oral tube with the oral valve in the open position, to a graduated water manometer (or a similar digital device for measuring back pressure).

Note: Hammar inflators must be tested with the Hammar operating head fitted to the inflation chamber.

6.1.1.2 Slowly inflate the lifejacket from a regulated supply until manometer reads 200mbar

Warning: Regulated supply pressure must not exceed 20psi.

6.1.1.3 Close off the air supply and leave for 10 minutes to ensure pressure is stable.

6.1.1.4 Check and record the pressure and temperature reading on the Service Record Sheet.

6.1.1.5 Leave for 30 minutes.

6.1.1.6 Check and record the pressure and temperature reading on the Service Record Sheet.

The maximum difference in the two pressure readings (pressure drop) allowed is 10%. The temperature differential shall be within plus or minus 3 degrees of the original reading. For each degree Centigrade rise in temperature subtract 2.5 mbar. For each degree Centigrade drop in temperature add 2.5 mbar to the readings to obtain the actual pressure variation. Should the temperature variation be outside 3 degrees either way then the test shall be repeated.

PSI	mH ₂ O	mHg	mmH ₂ O	mmHg	kg/cm ₂	bar	mbar	Pa	kPa
1.0	27.71	2.036	703.1	51.75	0.0703	0.0689	68.95	6895	6.895
1.1	30.48	2.240	773.4	56.93	0.0773	0.0758	75.85	7585	7.585
1.2	33.25	2.443	843.7	62.10	0.0844	0.0827	82.74	8274	8.274
1.3	36.02	2.647	914.0	67.28	0.0914	0.0896	89.64	8964	8.964
1.4	38.79	2.850	984.3	72.45	0.0984	0.0965	96.53	9653	9.653
1.5	41.57	3.054	1054.7	77.63	0.1055	0.1034	103.43	10343	10.34
1.6	44.34	3.258	1125.0	82.80	0.1125	0.1102	110.32	11032	11.03
1.7	47.11	3.461	1195.3	87.98	0.1195	0.1171	117.22	11722	11.72
1.8	49.88	3.665	1265.6	93.15	0.1265	0.1240	124.11	12411	12.41
1.9	52.65	3.868	1335.9	98.33	0.1336	0.1309	131.01	13101	13.10
2.0	55.42	4.072	1406.2	103.50	0.1406	0.1378	137.90	13790	13.79
2.1	58.19	4.276	1476.5	108.68	0.1476	0.1447	144.80	14480	14.48
2.2	60.96	4.479	1546.8	113.85	0.1547	0.1516	151.69	15169	15.17
2.3	63.73	4.683	1617.1	119.03	0.1617	0.1585	158.59	15859	15.86
2.4	66.50	4.886	1687.4	124.20	0.1687	0.1654	165.48	16548	16.55
2.5	69.28	5.090	1757.8	129.38	0.1758	0.1723	172.38	17238	17.24
2.6	72.05	5.294	1828.1	134.55	0.1828	0.1791	179.27	17927	17.93
2.7	74.82	5.497	1898.4	139.73	0.1898	0.1860	186.17	18617	18.62
2.8	77.59	5.701	1968.7	144.90	0.1968	0.1929	193.06	19306	19.31
2.9	80.36	5.904	2039.0	150.08	0.2039	0.1998	199.96	19996	20.00
3.0	83.13	6.108	2109.3	155.25	0.2109	0.2067	206.85	20685	20.69
3.1	85.90	6.312	2179.6	160.43	0.2179	0.2136	213.75	21375	21.37
3.2	88.67	6.515	2249.9	165.60	0.2250	0.2205	220.64	22064	22.06
3.3	91.44	6.719	2320.2	170.78	0.2320	0.2274	227.54	22754	22.75
3.4	94.21	6.922	2390.5	175.95	0.2390	0.2343	234.43	23443	23.44
3.5	96.99	7.126	2460.9	181.13	0.2461	0.2412	241.33	24133	24.13
3.6	99.76	7.330	2531.2	186.30	0.2531	0.2480	248.22	24822	24.82
3.7	102.53	7.533	2601.5	191.48	0.2601	0.2549	255.12	25512	25.51
3.8	105.30	7.737	2671.8	196.65	0.2671	0.2618	262.01	26201	26.20
3.9	108.07	7.940	2742.1	201.83	0.2742	0.2687	268.91	26891	26.89
4.0	110.84	8.144	2812.4	207.00	0.2812	0.2756	275.80	27580	27.58
4.1	113.61	8.348	2882.7	212.18	0.2882	0.2825	282.70	28270	28.27
4.2	116.38	8.551	2953.0	217.35	0.2953	0.2894	289.59	28959	28.96
4.3	119.15	8.755	3023.3	222.53	0.3023	0.2963	296.49	29649	29.65
4.4	121.92	8.958	3093.6	227.70	0.3093	0.3032	303.38	30338	30.34
4.5	124.70	9.162	3164.0	232.88	0.3164	0.3101	310.28	31028	31.03
4.6	127.47	9.366	3234.3	238.05	0.3234	0.3169	317.17	31717	31.72
4.7	130.24	9.569	3304.6	243.23	0.3304	0.3238	324.07	32407	32.41
4.8	133.01	9.773	3374.9	248.40	0.3374	0.3307	330.96	33096	33.10
4.9	135.78	9.976	3445.2	253.58	0.3445	0.3376	337.86	33786	33.79
5.0	138.55	10.180	3515.5	258.75	0.3515	0.3445	344.75	34475	34.48
5.1	141.32	10.384	3585.8	263.93	0.3585	0.3514	351.65	35165	35.16
5.2	144.09	10.587	3656.1	269.10	0.3656	0.3583	358.54	35854	35.85
5.3	146.86	10.791	3726.4	274.28	0.3726	0.3652	365.44	36544	36.54
5.4	149.63	10.994	3796.7	279.45	0.3796	0.3721	372.33	37233	37.23
5.5	152.41	11.198	3867.1	284.63	0.3867	0.3790	379.23	37923	37.92
5.6	155.18	11.402	3937.4	289.80	0.3937	0.3858	386.12	38612	38.61
5.7	157.95	11.605	4007.7	294.98	0.4007	0.3927	393.02	39302	39.30
5.8	160.72	11.809	4078.0	300.15	0.4077	0.3996	399.91	39991	39.99
5.9	163.49	12.012	4148.3	305.33	0.4148	0.4065	406.81	40681	40.68
6.0	166.26	12.216	4218.6	310.50	0.4218	0.4134	413.70	41370	41.37

6.1 Inflation Chamber cont.

- 6.1.1.7. If Lifejacket fails the Air holding test inspect as follows.
- 6.1.1.7.1 With the lifejacket inflated carefully brush or spray the surface with a weak solution of soap and water or alternatively lower the lifejacket into a tank of water to observe for bubbles.
 - 6.1.1.7.2 Identify and mark the source of leakage. Wash off in clean water and allow to dry naturally in air.
 - 6.1.1.7.2.1 Special Attention to be given to:
 - a) Manifold Schraeder Core
 - b) Oral Tube/ Top-up Valve
- 6.1.2 If the test is satisfactory deflate the Lifejacket in preparation for re-assembly. Refer to Section 8.
- 6.1.2.1. Insert the inverted oral valve dust cap into the top of the oral valve and expel the air. Lifejackets may also be deflated using the Venturi Vacuum System. For the part number, refer to Section 9.

6.2 Valves

- 6.2.1. Oral Valve.
- 6.2.1.1. When removing the test adapter from each oral valve check that the oral valve reseats. If in doubt this may be checked by placing the valve underwater.
- 6.2.2 Schraeder Valve.
- 6.2.2.1 Should a leak be found in the Schraeder valve the faulty core must be removed and a new valve inserted using the Torque Screwdriver from the tool kit.

6.3 Inflation Mechanisms

- 6.3.1 Operational Test for Manual Operation.
- 6.3.1.1 Remove the operating mechanism from the lifejacket. With the cylinder also removed, pull the lever on the side of the operating head, and check that the firing pin is visibly moving inside the open end.
 - 6.3.1.2 If the lever does not move, or the firing pin is not clearly moving, the operating head must be replaced. Refer to Section 9 for part number.
- 6.3.2 Operational Test for Automatic Operating Heads (to be performed when capsules have expired).
- 6.3.2.1 Remove the operating mechanism from the lifejacket and remove the cylinder.
 - 6.3.2.2 Assemble the expired capsule onto the body of the operating mechanism.
 - 6.3.2.3 Place the complete unit into water and check that the unit operates within 5 seconds.
 - 6.3.2.4 If the mechanism fails to pass repeat test replace the complete unit. Refer to Section 9 for part Number of the replacement part.

NOTE: all failures of this test must be reported to Crewsaver. Crewsaver may require the failed units to be returned. Please do not discard.

6.4 Retro Reflective Tape

- 6.4.1 If the retro reflective tape shows any signs of degradation the following tests shall be carried out in accordance with Marine Guidance Note MGN 105 (M+F) Issued by the UK Marine and Coast guard Agency March 1999.
- 6.4.1.1 Place a new piece of the same retro-reflective material to, and on the same plane as, a representative piece of material fitted to the appliance.
 - 6.4.1.2 Pour water over both pieces of material.
 - 6.4.1.3 Using a powerful torch or "Aldis" lamp held at eye level, compare the performance of the two pieces of material from a distance of 10 Metres.
 - 6.4.1.4 If a noticeable deterioration in performance is observed then the retro-reflective material on the appliance should be replaced.
 - 6.4.1.5 Dry off the lifejacket before repacking.

6.5 Lights

- 6.5.1. Testing Procedure for lights fitted to lifejackets.
- 6.5.1.1 Crewsaver CSL Water Activated Light.

Test the light by immersing the sensor in water. The light must flash, remove the light from the water and dry it. The light must stop flashing. If the light does not flash the unit has expired and must be replaced.

7.1 Outer Cover

7.1.1 No repairs are permitted to the outer cover.

7.2 Inflation Chamber

7.2.1 No repairs are permitted to the inflator fabric or its assembly, due to the construction of this lifejacket.

7.2.2 Components attached to the inflator may be repaired in line with the limits defined below.

7.3 Gas Cylinders

7.3.1 No repairs permitted. For the Part No. of the replacement part refer to Section 9

7.3.2 Please ensure cylinders are disposed of in accordance with local regulations.
Treat empty cylinders as steel for recycling purposes.

7.4 Valves

7.4.1 No repairs permitted. For the Part No. of the replacement parts refer to Section 9

7.4.2 Replacement of the Oral valve may be achieved by.

7.4.2.1 Carefully removing the defective unit by applying force, with a blunt instrument, behind the oral valve Squeezing the tube and gently pushing the valve out.

7.4.2.2 Push the replacement valve into the oral tube.

Fig. 7.4

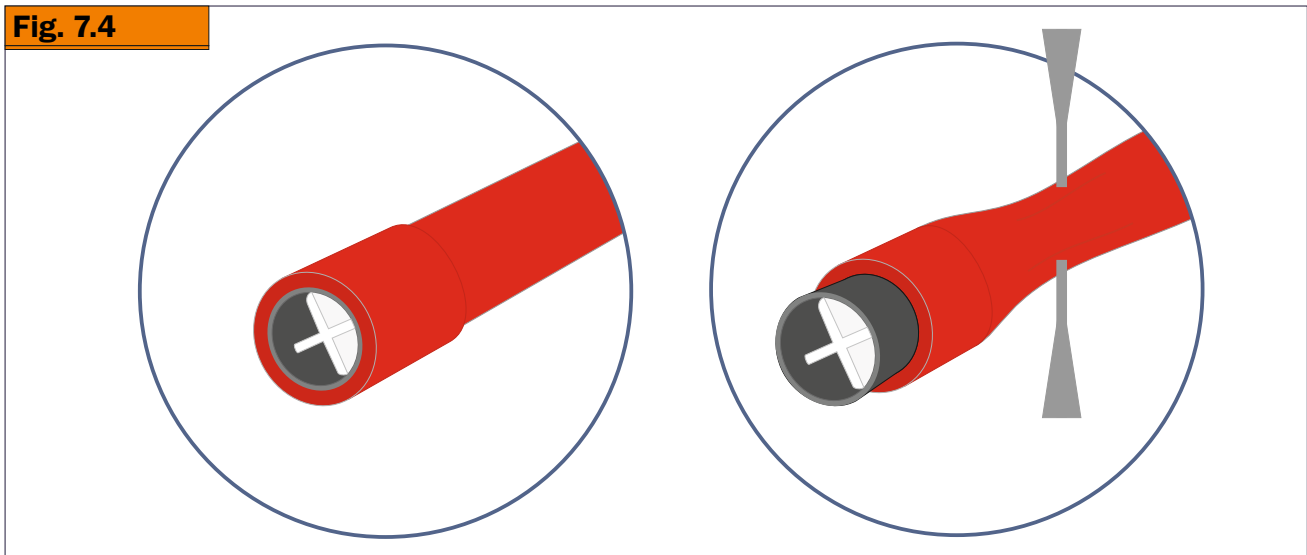

7.5 Inflation System

7.5.1 A Schrader core is located inside the Valve Stem.

7.5.1.1 Remove and replace using the calibrated torque driver for Schrader valves set to 0.32 - 0.36 Nm. Refer to Section 9 for the Part No. of the replacement part.

WARNING: Only fit replacement Schrader valves obtained from Crewsaver.

7.5.2 Operating Mechanism.

7.5.2.1 No repairs permissible. Replace the complete unit. Refer to Section 9 for the Part No. of the replacement part.

7.6 Webbing

7.6.1 These components are not repairable or replaceable. Lifejackets with damaged webbing should be returned to Crewsaver.

7.7 Buckles

7.7.1. These components are not repairable or replaceable. Lifejackets with damaged buckles should be returned to Crewsaver.

8.1 Assembly

- 8.1.1 Ensure the whistle is positioned and tied in correctly.
- 8.1.2 Expel the air from the chamber by inverting the dust cap on the oral tube. Lifejackets may also be deflated using the Crewsaver Venturi Vacuum System. For the part number, refer to Section 9.
- 8.1.3 Assemble the Operating Mechanism to the inflator.
 - 8.1.3.1 For Halkey Roberts Manual Operating Mechanisms. See Fig 8.2
 - 8.1.3.1.1 A new firing retaining pin/ clip, upper and lower manifold gaskets must be fitted. Refer to Section 9 for Part Numbers.
 - 8.1.3.1.2 Fit new lower gasket.
 - 8.1.3.1.3 Locate operating head onto manifold.
 - 8.1.3.1.4 Fit new top gasket.
 - 8.1.3.1.5 Tighten the retaining nut onto the body using the Calibrated torque driver provided in the Crewsaver servicing tools. Note: Retaining nut must be tightened to between 2.5 and 2.7 Nm.
 - 8.1.3.1.6 Firmly screw the cylinder adaptor by hand into the head
 - 8.1.3.1.7 Connect the cylinder adaptor to the pressure test unit
 - 8.1.3.1.8 Pressurise the head to between 25 and 30 psi and release the control to its vertical position.
 - 8.1.3.1.9 There may be a slight decrease in pressure over the first 2 seconds as the unit stabilises. Leave for 10 seconds and check for any further decrease in pressure shown on the gauge
 - 8.1.3.1.10 Release the pressure by turning the control to deflate.
 - 8.1.3.1.11 If there had been any decrease in pressure remove the cylinder adaptor, remove the operating head and check the following.
 - a. Thick and thin washer either side of the head.
 - b. Damage to the D post seating.
 - c. Cross thread chrome nut
 - d. The cylinder seating washer.
 - e. The schrader or pang valve in the 'D' post.
 - f. The operating head
 - 8.1.3.1.12 Fit the gas cylinder to the firing mechanism by hand then check using the torque wrench (4Nm) and head adaptor from the tool kit. The operating head is gripped in one hand and the cylinder tightened using the torque wrench with the cylinder tightening tool held in the other hand.

Warning: Care must be taken not to 'cross thread' the connection.

- 8.1.3.2 For United Moulders Mk5 Automatic Operating Mechanisms. See Fig 8.3
 - 8.1.3.2.1 A new retaining clip must be fitted. Refer to Section 9 for replacement parts.
 - 8.1.3.2.2 Fit the new automatic firing capsule to the operating head, screw hand tight.
 - 8.1.3.2.3 Locate Operating head onto the Manifold.
 - 8.1.3.2.4 Tighten the retaining nut onto the body using the Calibrated torque driver provided in the Crewsaver servicing tools. Note: Retaining nut must be tightened to between 2.5 and 2.7 Nm.
 - 8.1.3.2.5 Firmly screw the cylinder adaptor by hand into the head
 - 8.1.3.1.6 Connect the cylinder adaptor to the pressure test unit
 - 8.1.3.1.6 Pressurise the head to between 25 and 30 psi and release the control to its vertical position.
 - 8.1.3.1.7 There may be a slight decrease in pressure over the first 2 seconds as the unit stabilises. Leave for 10 seconds and check for any further decrease in pressure shown on the gauge
 - 8.1.3.1.8 Release the pressure by turning the control to deflate.
 - 8.1.3.1.9 If there had been any decrease in pressure remove the cylinder adaptor, remove the operating head and check the following.
 - a. Thick and thin washer either side of the head.
 - b. Damage to the D post seating.
 - c. Cross thread chrome nut
 - d. The cylinder seating washer.
 - e. The schrader or pang valve in the 'D' post.
 - f. The operating head

Warning: Care must be taken not to 'cross thread' the connection.

8.1.3.2.10 Fit the gas cylinder to the firing mechanism by hand then check using the torque wrench and head adaptor from the tool kit (4Nm). The operating head is gripped in one hand and the cylinder tightened using the torque wrench with the cylinder tightening tool held in the other hand.

Warning: The lifejacket folding procedures must be followed accurately to ensure that the lifejacket inflation mechanism operates and the lifejacket deploys correctly. The lifejacket shall not be folded and/or packed using any other method or procedure than that specified.

Fig 8.2 Halkey Roberts Operating Head

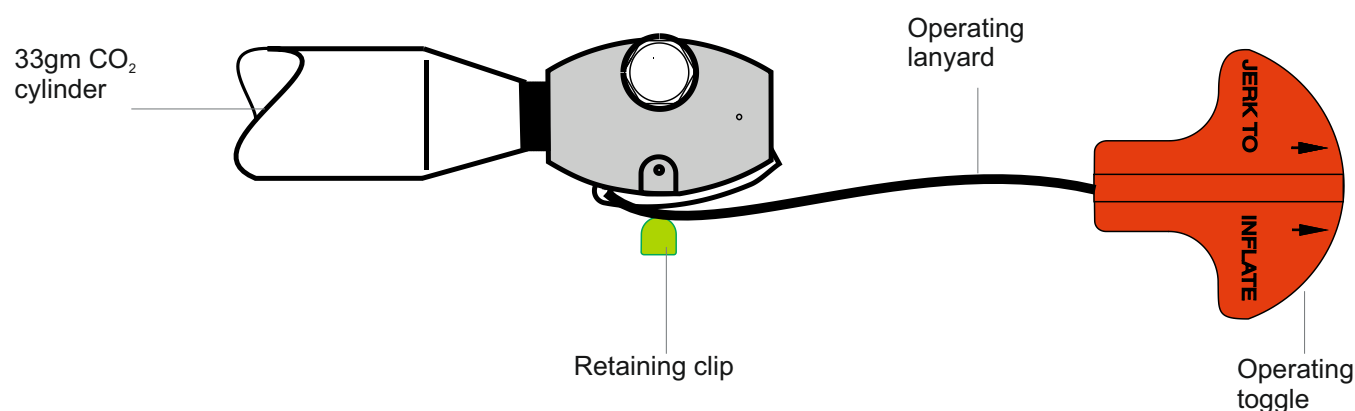

1. Following the inspection and testing procedures for Halkey Roberts Manual operating heads as detailed in Section 5 and 6. Fit the retaining clip by pressing it over the firing arm and in to the recess either side in the centre of the operating head. The clip will click into place, thereby preventing the arm from moving
2. Check that the cylinder sealing gasket in the end of the operating head has been correctly fitted, or replace if necessary. Ensure that the cylinder has been check weighed before fitting to the lifejacket. Fit the gas cylinder to the firing mechanism using the torque wrench (4Nm) and head adaptor from the tool kit. The cylinder is gripped in one hand and the head tightened using the torque wrench held in the other hand.
3. Fit the new bottom sealing washer on to the manifold. The washer must sit flat on the manifold and lie underneath the bottom collar at the base of the manifold. Before fitting the operating head onto the manifold, Check that the schrader valve is fitted - if fitting a new schrader valve use a calibrated torque driver set to 0.32 - 0.36 Nm. Then place the operating head onto the manifold, so that the cylinder is pointing upwards.
4. With the operating head fitted to the manifold, place the top sealing washer into the recess over the protruding end of the manifold. The two washers differ in size as shown below:-

Bottom Sealing Washer



Top Sealing Washer

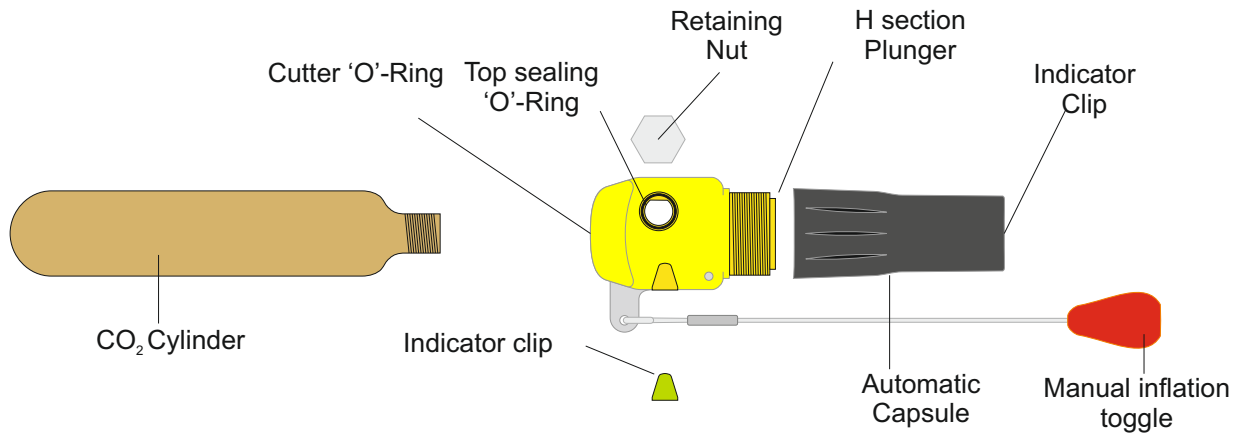

5. With the top washer in place, fit the retaining nut. The retaining nut should be screwed in to place using a torque wrench or driver fitted with a 9/16" socket. The wrench or driver should be set to between 2.5 and 2.7 Nm. This will prevent damage to the operating head and ensure a good seal is maintained.

Fig 8.3 United Moulders Mk5 Operating Head

1. Check that the Cutter 'O'-Ring in the end of the operating head has been correctly fitted, or replace if necessary. Fit the 33 gram CO₂ cylinder. Ensure that the cylinder has been check weighed before fitting to the lifejacket. Fit the gas cylinder to the firing mechanism using the torque wrench (4Nm) and head adaptor from the tool kit. The cylinder is gripped in one hand and the head tightened using the torque wrench held in the other hand.
2. Fit the new automatic capsule onto the operating head. The capsule fitted on the United Moulders Mk5 head is the black Mk5i capsule. The capsule should be screwed tight to the end. Make a note of the expiry date on to service record sheet.
3. With the firing capsule fitted, fit the indicator clip. The clip is fitted by pressing it over the firing arm and in to the recess either side in the centre of the operating head. The clip will click into place, thereby preventing the arm from moving.
4. Check the bottom O-ring seal is in place. Before fitting the operating head onto the manifold, check that the schrader valve is fitted. If fitting a new schrader valve use a calibrated torque driver set to 0.32 - 0.36 Nm. Then place the operating head onto the manifold , so that the cylinder is pointing upwards.
5. Check the O-ring seal is in the recess on the top face of the operating head. With the top O-ring in place, fit the retaining nut. The retaining nut should be screwed into place using a torque wrench or driver fitted with a 9/16" socket. The wrench or driver should be set to between 2.5 and 2.7 Nm. This will prevent damage to the operating head and ensure a good seal is maintained.

Fig 8.4 Crewfit 165 Packing Instructions

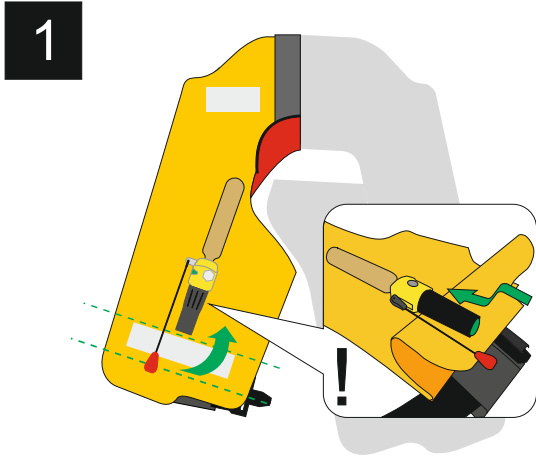

Start by folding the bottom left of chamber up over operating head then fold in half to make a concertina underneath the inflation mechanism.

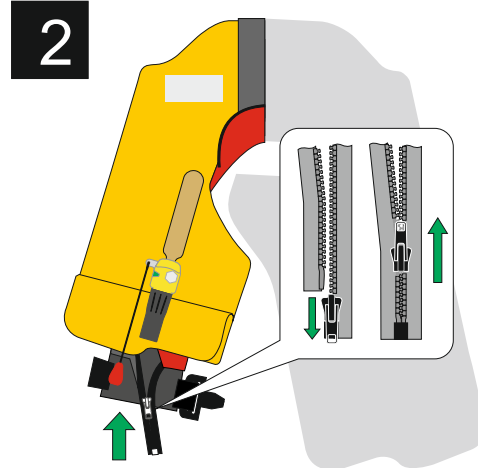

Start to close the zip.

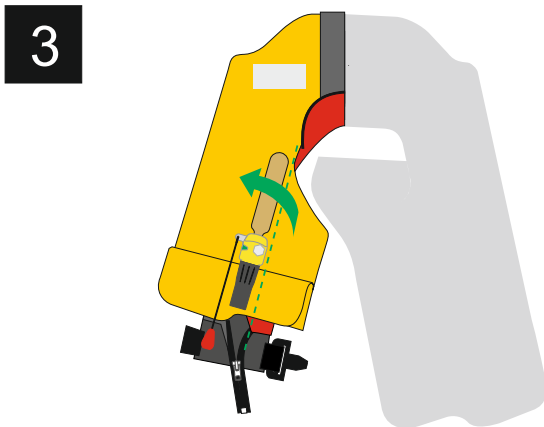

Fold inner side over to the other side.

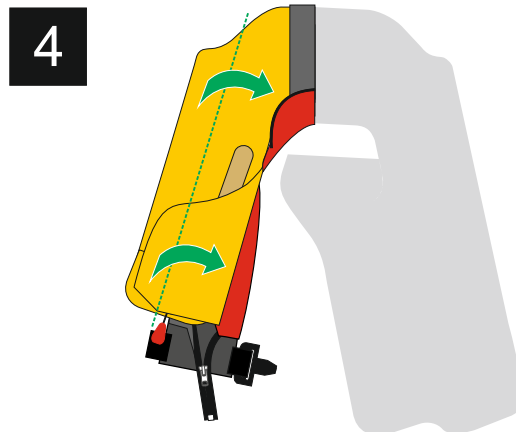

Fold the outside edge over the firing mechanism.

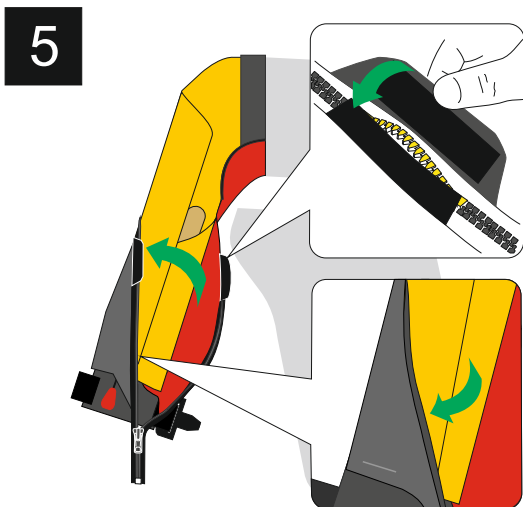

Tuck chamber inside the cover and secure in place with the velcro tabs.

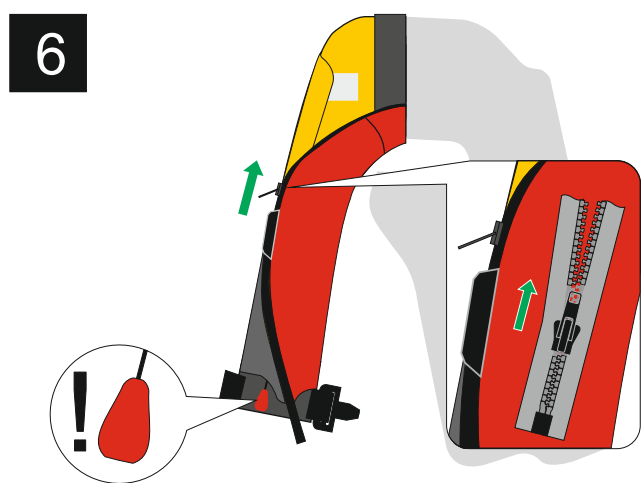

Do up zip past velcro tab. Ensure the manual pull toggle is accessible.

Fig 8.4 Crewfit 165 Packing Instructions

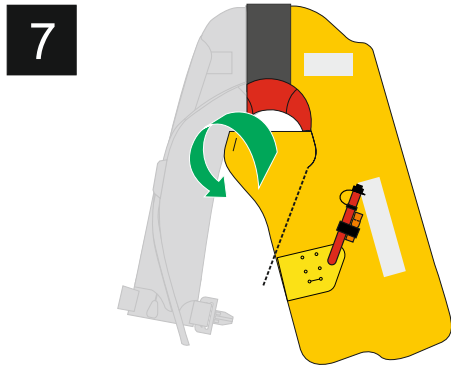

Fold the right side chin support diagonally underneath itself.

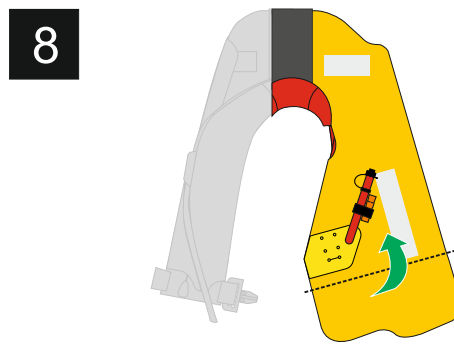

Fold the bottom right of the chamber up over the oral tube.

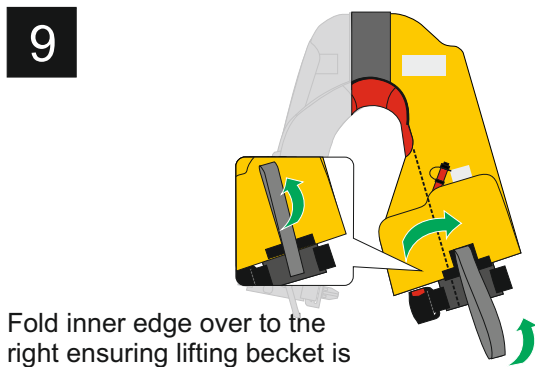

Fold inner edge over to the right ensuring lifting becket is folded up into the cover.

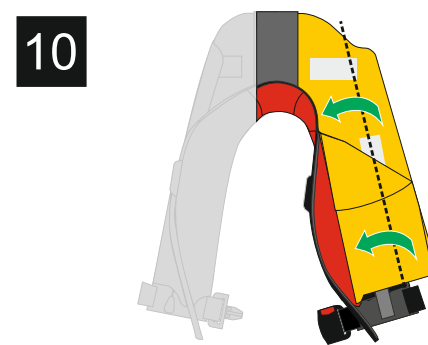

Fold the outside edge over.

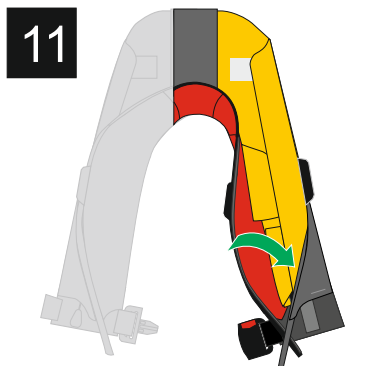

Tuck chamber inside the cover.



Secure cover in place with the velcro tabs.

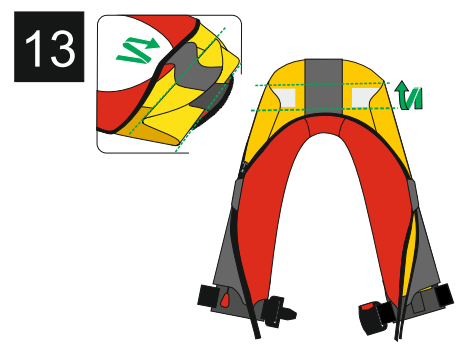

Concertina the chamber collar with two folds and tuck in the fabric neck retainer.

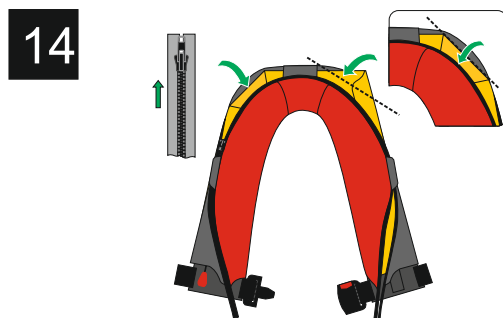

Fold in the last corners of the chamber and bring the zip round to close.



Make sure Velcro tabs are secure and zip ends are tucked up inside the cover.

9.1 Parts List

Part Description	Product Code
UM Mk5 Auto Head and Capsule	11044
UM Mk5i Auto Capsule, Black	10017
Halkey Roberts Manual Head	10550
33gm CO ₂ Cylinder	12040
UM Auto Head Sealing 'O' Ring (Top and Bottom)	10373
UM Auto Head Cutter 'O' Ring	11048
Manual Head Sealing Washer (Thick)	10096
Manual Head Sealing Washer (Thin)	10097
Auto Head Retaining Clip	11043
Manual Head Retaining Clip	10210
CSL Light	10226
Whistle	10678
Mouth Inflation Valve	10208
Mouth Inflation Valve Cap	10151
Schrader Valve	10049
Retaining Nut	11047
Venturi Vacuum System	10481
Servicing tool kit	10467
Cylinder adaptor for back pressure System	900032
Back pressure test unit	900031
Cylinder tightening tool	900030