



Crewsaver®

SERVICE MANUAL

HARVESTER LIFEJACKET AND SWR HARVESTER LIFEJACKET

Crewsaver®

Survitec House, Lederle Lane, Gosport,
Hants. PO13 0FZ, England.
Tel: +44 (0) 1329 820000 Fax: +44 (0) 1329 236218
email: crewsaver@survitecgroup.com
Web: www.crewsaver.com

 **survitecgroup**

Service Bulletins and Amendments Register

No.	Description	Date
Issue 2	Page 4 - change in procedure for accessing manuals on the website. Section 5.10 - Expired L6 Lights to be replaced by CSL Lights. New Section 6.6 added regarding testing of Lights. CSL Light added to Parts List. Reference to Venturi Vacuum System added (sections 6.1.2, 8.1.2 and Parts List) Back pressure testing of the operating head added	November 2015

Scope

This manual covers the servicing of the Harvester range of 150N lifejackets. The elements contained within the manual also cover other types of lifejacket as listed below. Training will have been given in these lifejackets and if any aspect is critical to its operation this will be shown in this manual.

1. SWR Harvester Lifejacket
2. Coastguard Water Rescue Lifejacket

Index

Section 1	1.1	Introduction
	1.2	Product Description
	1.3	Data Sheet
	1.4	General Features
Section 2	2.1	Service Station Guidelines
	2.2	On Receipt Inspection
	2.3	General Care
	2.4	Servicing Tools
	2.5	Lifejacket Servicing Record Sheet
Section 3	3.1	Unpacking the Lifejacket
Section 4	4.1	Cleaning Lifejackets
Section 5	5.1	Inspection
Section 6	6.1	Testing
Section 7	7.1	Repairs
Section 8	8.1	Assembly
Section 9	9.1	Replacement Parts

1.1 Introduction

- 1.1.1. This Service Manual will be published on the Crewsaver website (www.crewsaver.com). Click on PARTNER /LOGIN at the top of the screen. Personnel who have been trained in the servicing procedures for this lifejacket will be issued with a Username and Password to enable them to access the download section. Each manual carries an Issue Number and records of issue are logged by Crewsaver to ensure that the service network maintains correct and up to date servicing information. Emails will be sent regarding any new Issues. Periodically service bulletins may be issued which will be published on the Crewsaver website (www.crewsaver.com). Emails will also be sent. It is the service station's responsibility to regularly check the website for any new bulletins and to ensure inclusion within the servicing manual. The service bulletin register at the front of the Manual should be completed.
- 1.1.2. The information referenced in each section follows a standard servicing procedure by which the inspection should take place.
- 1.1.3. This servicing manual details information to enable regular maintenance and servicing of the lifejacket to help prolong the life of the product and ensure it functions correctly.
- 1.1.4. The manual should be used as a reference document following training in servicing procedures instructed by Crewsaver personnel. The manual also details the equipment and parts needed for correct maintenance to be performed.
- 1.1.5. Servicing must be carried out annually at a service station authorised by the manufacturer 
- 1.1.6. Regular servicing is to be carried out by qualified personnel trained by Crewsaver or and holding a valid servicing certificate. Certificates are valid for a period of 3 years.

1.2 Product Description

- 1.2.1. The Harvester Lifejacket combines the comfort of a 50N buoyancy aid and its inherent buoyancy with a full 150N Lifejacket when the inflation chamber is deployed.
- 1.2.2. The lifejacket is CE approved to EN 396 -150N Lifejackets.
- 1.2.3. The lifejacket is easy to don and work in whilst still retaining high in-water performance.
- 1.2.4. The buoyancy of the jacket is provided by a 150N single chamber combined with 50N of foam. An oral tube is available to ensure that the full buoyancy can be achieved upon or after inflation.
- 1.2.5. This lifejacket is available with either manual or standard automatic operation and acts as a 50N buoyancy aid without the chamber inflated. It can be fitted with a light that is operated when the lifejacket inflates.
- 1.2.6. This lifejacket comes in a waistcoat version with a heavy duty front zip.
- 1.2.7 The outer cover is made from a hard wearing red material.
- 1.2.8 The inflation chamber can be removed from the jacket to allow for replacement if necessary.
- 1.2.9 The SWR version is fitted with a quick release harness belt and crutch straps.

1.3.1 Data Sheet

Features:	Harvester Lifejacket
Chamber Buoyancy	160N
Permanent Buoyancy	50N
Buoyancy Category	150N
Cover Colour	Red
MCA (UK) Approved	-
SOLAS Approved	-
CE Approved	X
Cylinder size	33g
Standard Automatic	X
Hammar Automatic	-
Manual Firing head	X
Manual Override	X
Oral inflation tubes	X
Pressure relief valves	N/A
Hard wearing cover	X
Whistle - fitted	X
Retro-reflective tape	X
Lifting Becket - fitted	X
Light - fitted	Optional
Spray Hood	-
Thigh straps - fitted	X
Fall Arrest Harness	N/A
Closure method	Zip and interlocking stainless steel buckle
Alternative covers	-

1.3.2 Data Sheet

Features:	SWR Harvester Lifejacket
Chamber Buoyancy	160N
Permanent Buoyancy	50N
Buoyancy Category	150N
Cover Colour	Red
MCA (UK) Approved	-
SOLAS Approved	-
CE Approved	X
Cylinder size	33g
Standard Automatic	X
Hammar Automatic	-
Manual Firing head	X
Manual Override	X
Oral inflation tubes	X
Pressure relief valves	N/A
Hard wearing cover	X
Whistle - fitted	X
Retro-reflective tape	X
Lifting Becket - fitted	X
Light - fitted	Optional
Spray Hood - fitted	-
Thigh straps - fitted	X
Fall Arrest	N/A
Quick release belt	X
Closure method	Zip and interlocking stainless steel buckle
Alternative covers	Blue (Coastguard WR Lifejacket)

1.4.1 General Features - Harvester Lifejacket

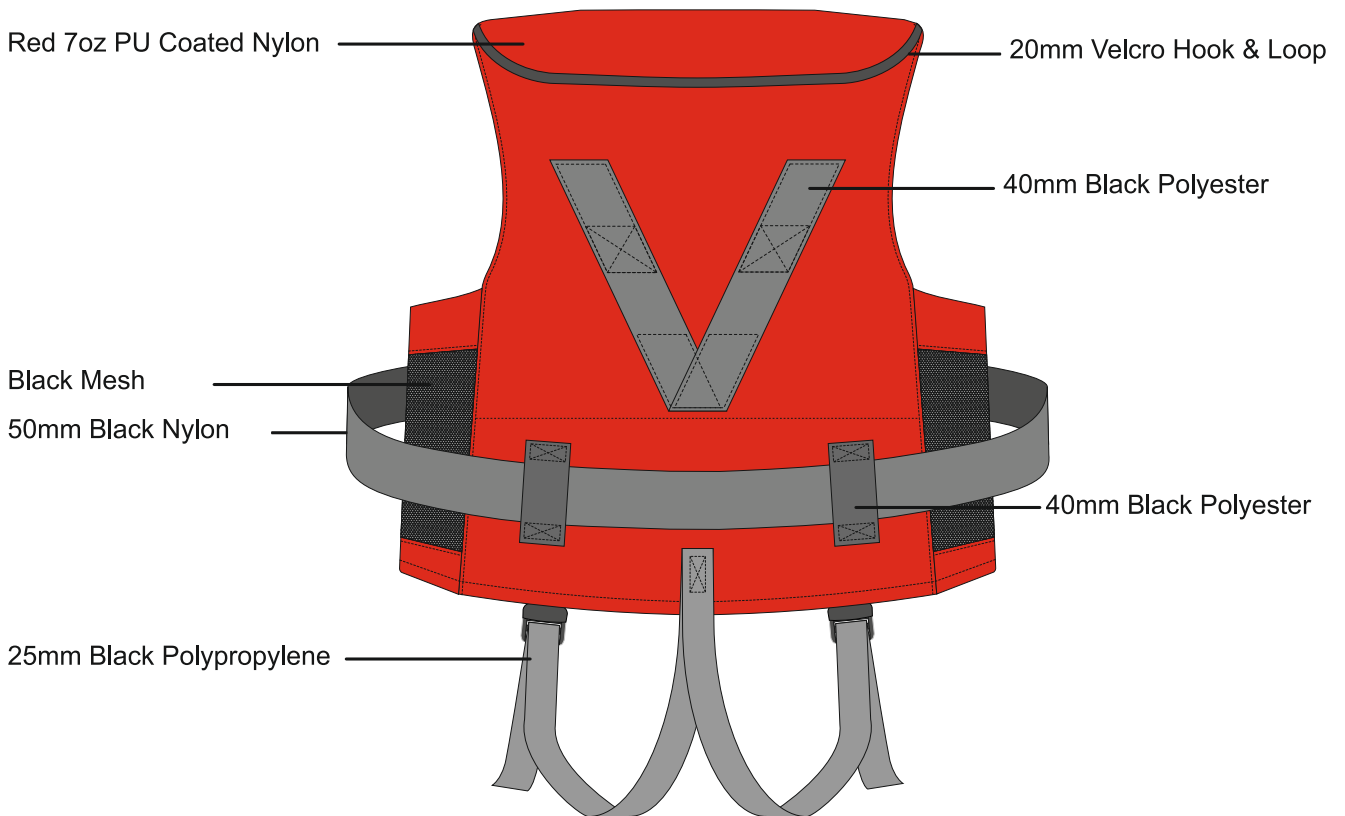

1.4.2 General Features - SWR Harvester Harness

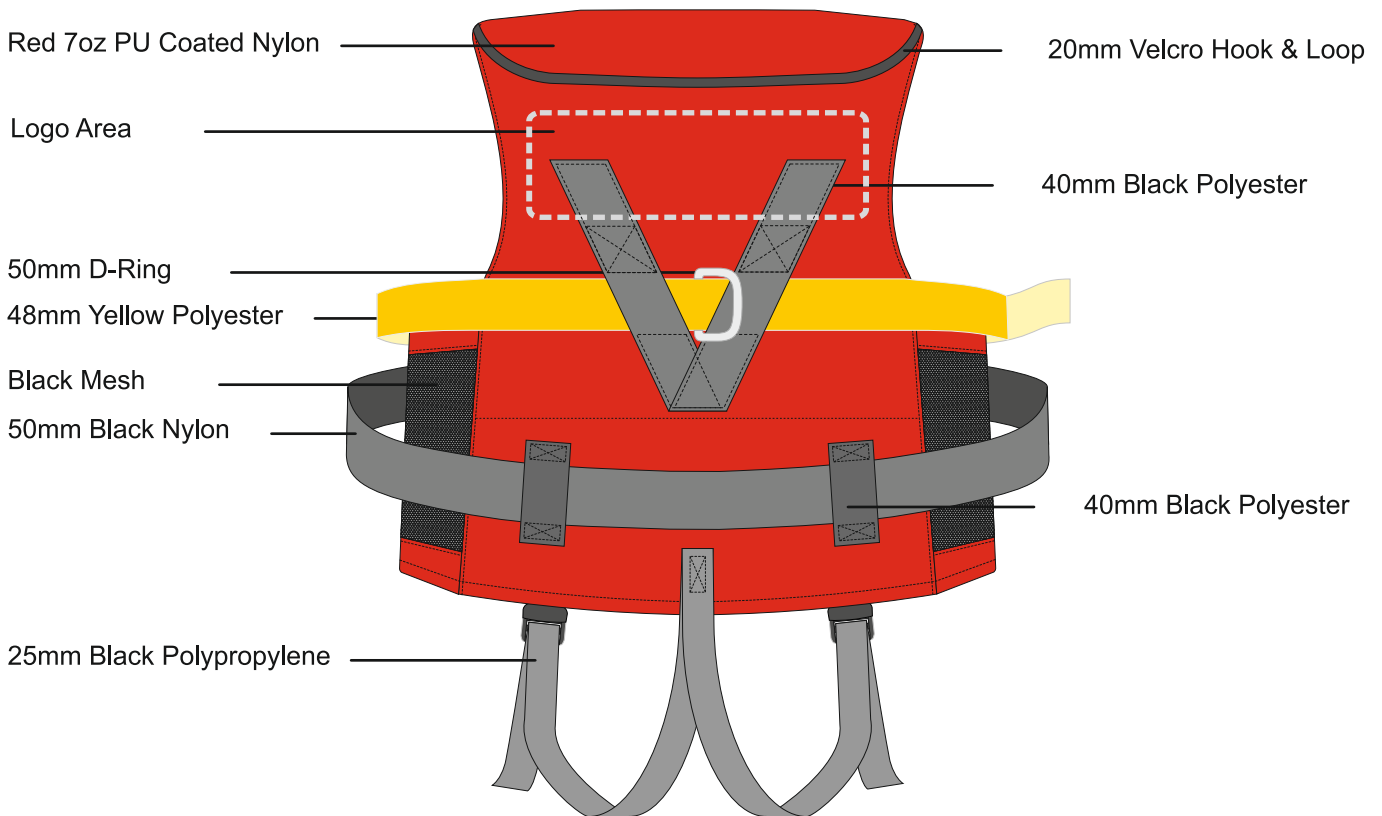
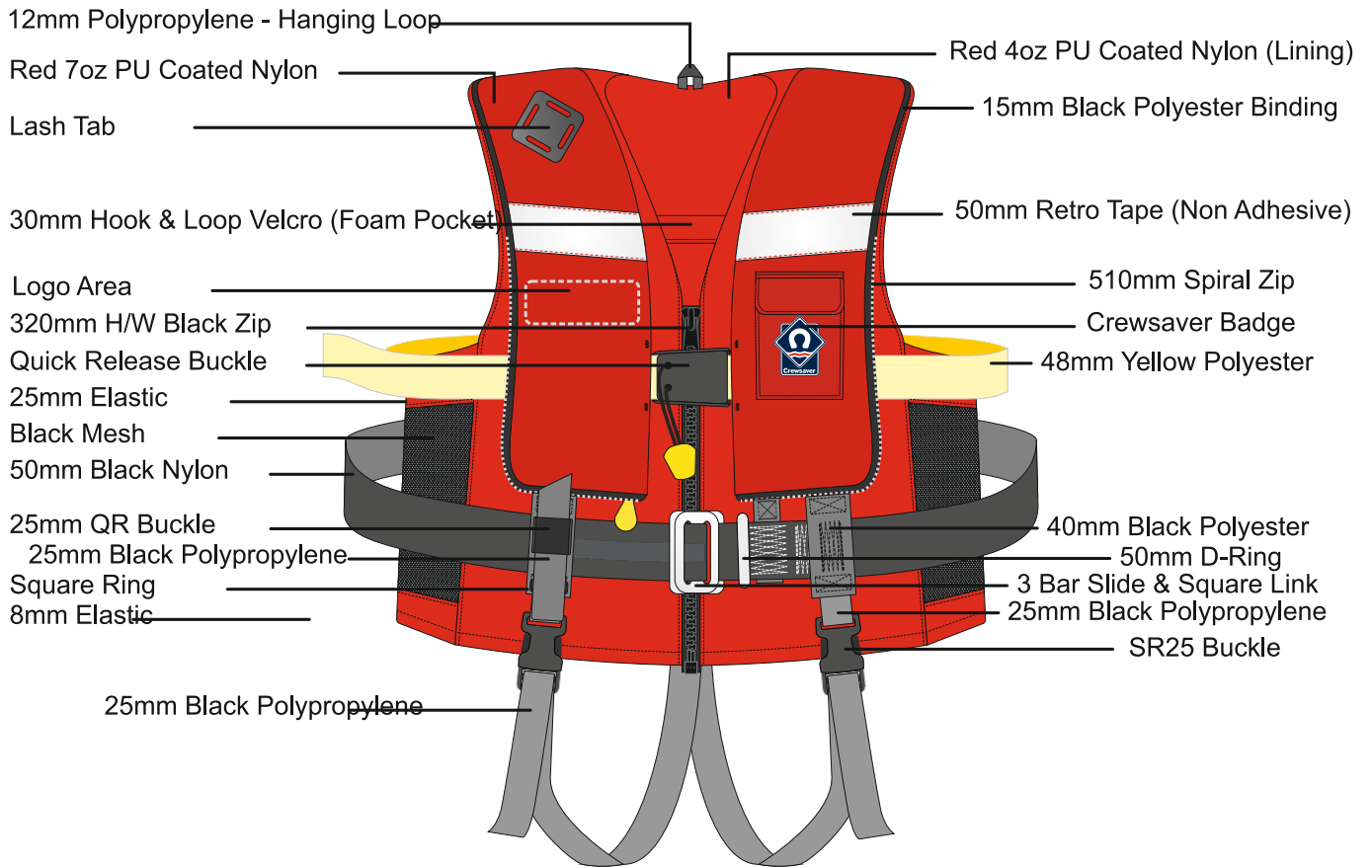

1.4.3 General Features - Coastguard WR Lifejacket

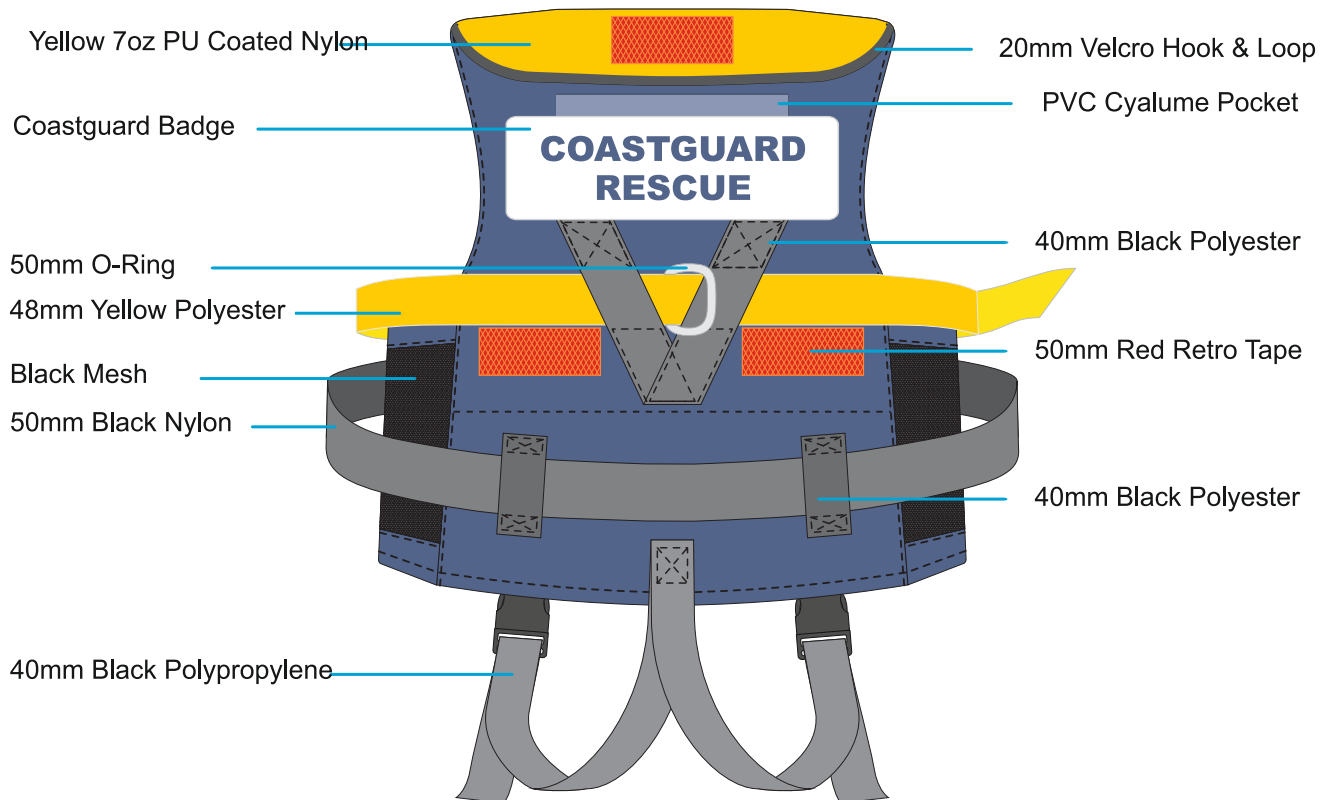
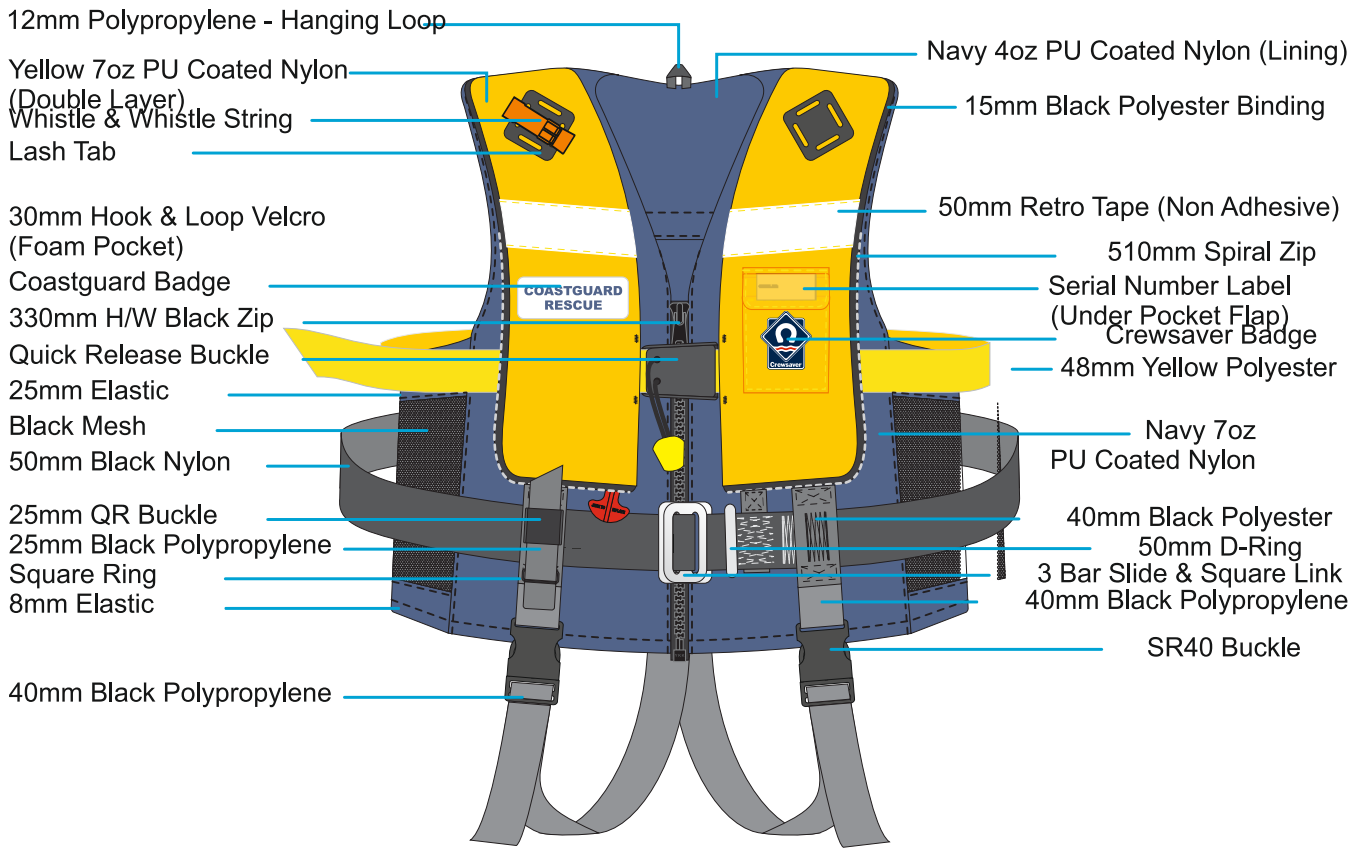

2.1 Service Stations

- 2.1.1 Service stations shall comply with the following as a minimum;
 - 2.1.1.1 Servicing of Inflatable Lifejackets shall be carried out in a fully enclosed area only.
 - 2.1.1.2 The area shall be well lit and protected from direct sunlight.
 - 2.1.1.3 The temperature and humidity shall be sufficiently controlled to ensure that the servicing of inflatable Lifejackets may be carried out successfully.
 - 2.1.1.4 The area shall be efficiently ventilated but free from draught.
 - 2.1.1.5 Sufficient tools (including specialist tools) shall be available to ensure Lifejackets may be disassembled, tested and reassembled in accordance with this Manual. These shall include but not limited to:
 - 2.1.1.5.1 Manometers and pressure gauges.
 - 2.1.1.5.2 Oil free and dry air supply.
 - 2.1.1.5.3 Scales for weighing Gas Cylinders.
 - 2.1.1.5.4 Crewsaver Service tool kit (See 2.6). This is recommended but similar calibrated devices may also be used.
 - 2.1.1.6 Stock of materials and components to allow efficient servicing with readily available replacement parts to ensure a prompt service for the customer.
 - 2.1.1.7 Only personnel trained and certified in accordance with Crewsaver requirements are approved to carry out Servicing and Maintenance. They must be holders of a valid Certificate issued by Crewsaver.
 - 2.1.1.8 The service station shall be of an approved standard.
 - 2.1.1.9 Procedures shall be introduced to ensure that service bulletins, Manuals and replacement parts are obtained from Crewsaver.
 - 2.1.1.10 Subsequent to initial approval and thereafter the service station shall be subject to regular surveillance by Crewsaver.
 - 2.1.1.11 The service station must comply and have met all QA criteria in the Crewsaver servicing protocol file.

2.2 On Receipt Inspection

- 2.2.1 On receipt of the Lifejacket(s), check the state of the packaging before opening and notify the owner and the company delivering the package of any defects or damage.
- 2.2.2 On opening the package, check the contents for their general condition and quantity.
- 2.2.3 Prepare Servicing Record Sheet.
- 2.2.4 Visually inspect the cover and inflation chamber for damage, abrasion, contamination etc. In accordance with this manual.
- 2.2.5 Note repairs or replacements required on the record sheet.
- 2.2.6 Unless obvious damage is evident, test the Lifejacket in accordance with Section 6. If it is considered that the damage found would cause the Lifejacket to fail the tests then corrective action shall be carried out prior to testing.
- 2.2.7 Damaged areas shall only be marked using wax based crayon. Marks shall be with a small circle or cross. Ballpoint, rollerball or other forms of ink shall not be used. If in doubt refer to Crewsaver for guidance.
- 2.2.8 Repairs to the outer cover are limited to that detailed in section 7.1.
- 2.2.9 Repairs to welded components including the inflation chamber are expressly forbidden.

2.3 General Care

- 2.3.1 The Lifejacket should be stowed in accordance with the manufacturer's instructions.
- 2.3.1.1 Lifejackets should be stowed in a dry compartment. Avoid high humidity, such as a car boot.
 - 2.3.1.2 Automatic Lifejackets should have stowage facilities which are provided with a method to encourage moisture removal.
 - 2.3.1.3 Lifejackets should be stowed vertically, for example hung on hooks, in order that any trapped water or condensation can drain away naturally.
 - 2.3.1.4 Lifejackets should be rinsed in fresh water and dried thoroughly after use.

WARNING

Prior to sponging or washing remove automatic capsules from the firing mechanism. Allow to dry thoroughly afterwards.

- 2.3.2 Contaminants such as oil or diesel fuel may be sponged off immediately with clean water and allowed to dry naturally.
- 2.3.3 Mud can be removed with a stiff (not wire) brush when dry.
- 2.3.4 The outer cover may be hand washed in good quality mild detergent in cool water (40°C). Rinse well, drip dry naturally in air.
- 2.3.5 Sponge the inflation chamber with pure soap solution only. Rinse in clean water immediately, inflate and allow to dry naturally in air.

WARNING

Do not use proprietary cleaning fluids, thinners, spirits or similar substances.

- 2.3.6 In cases of severe contamination the unit shall be deemed beyond economic repair and the customer advised to purchase a replacement lifejacket.

WARNING

Make sure you know how to use and fit this Lifejacket before an emergency occurs. Always try and inflate the Lifejacket in the water. If already inflated, cross arms over the chest before jumping.

- 2.3.7 It is advised that personnel are familiarised with the operation of all Lifejackets and lifesaving appliances.

2.4 Lifejacket Servicing Tools

Fig. 2.4 Table of Tools Required

Description	Type
Crewsaver Servicing Tool Kit A fine screw driver or tool suitable for removing gaskets Boning tool Roller Brushes Scissors or good quality trimming shears “Chinagraph” pencil Tailors chalk Fine point indelible pen 1 off metal calibrated metre stick Scales to weigh gas cylinders Adaptor/tee piece for testing inflation chambers. Manometer Timing Device Thermometer Clean and dry air supply 1 off ball pein hammer 450mm wide bag sealer (3mm element) Crewsaver Venturi Vacuum System Back pressure test unit	0-1000gram (+1/-1 grams) 0-500Mbar 0-40°C
Suitable large surface area for the work to be carried out 1 off FR steel cabinet (adhesive store) 1 off HD industrial sewing machine (e.g. Singer 96K, Juki, Durkopp etc.) <i>N.B. In case of difficulty contact Crewsaver direct (Not sewing machines, cabinets or tables. These parts may be sourced locally.)</i> <i>Note: Prior consent to carry out any repairs must be pre-approved by Crewsaver. All repairs to stitching must be in accordance with this manual.</i>	

2.5 Lifejacket Service Record Sheet

- 2.5.1. An electronic copy of the sheet is available to aid reproduction (or copy next page).
- 2.5.2. Each lifejacket serviced should be recorded either individually or as a batch, showing the serial numbers and the work performed during the service.
- 2.5.3. The service record sheet should be signed and a copy given to the owner certifying that the lifejacket has been serviced.
- 2.5.4. All replacement parts should be noted - recording either the serial numbers of the component or the expiry date.
- 2.5.5. The record sheet shown on the next page is a recommended version. Similar record sheets, including the same information, may also be used.



CERTIFICATE NUMBER:

LIFEJACKET SERVICING SCHEDULE

W/O Number:

TYPE	
CUSTOMER	
VESSEL	
LAST SERVICED BY	DATE OF LAST SERVICE

SERIAL NUMBER/S:

CHAMBER INSPECTION	<input type="checkbox"/> <input type="checkbox"/>	COMMENTS
GENERAL CONDITION		
MATERIAL		
WELDS		
WEBBINGS		
RETRO TAPE		
WHISTLE		
ORAL TUBES		
RELIEF VALVES		
MANIFOLDS		
Schrader VALVES		
CYLINDERS		
LIGHT		
CYALUME POCKET		
BUDDY LINE		

INFLATION MECHANISM	<input type="checkbox"/> <input type="checkbox"/>	COMMENTS
OPERATING MECHANISM		
CORD		
AUTOMATIC CAPSULE		
WASHERS		
RETAINING NUT		
RETAINING CLIP		
TOGGLE		

SPRAY HOOD	<input type="checkbox"/> <input type="checkbox"/>	COMMENTS
FABRIC		
ATTACHMENT		
VELCRO		

WEBBINGS	<input type="checkbox"/> <input type="checkbox"/>	COMMENTS
WAIST BELT / HARNESS		
BACK STRAP		
LIFTING BECKET		
CROTCH STRAP		
BUCKLES		
STITCHING		

COVER	<input type="checkbox"/> <input type="checkbox"/>	COMMENTS
MATERIAL		
VELCRO		
ZIP		
PLB POCKETS		

PRESSURE TEST RESULTS

TIME	FRONT CHAMBER	REAR CHAMBER
ON		
OFF		
TEMP.	ON	OFF

RELIEF VALVE TEST RESULTS

	FRONT CHAMBER	REAR CHAMBER
OPEN		
CLOSE		

REPAIRED ITEMS (COMMENTS)

SERVICED BY:

DATE:

2.6 Lifejacket Servicing Tool Kit

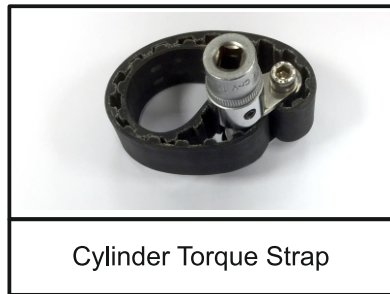

Cylinder Torque Strap



UML Mk5i Auto Socket



Manometer



Valve Extraction Tool

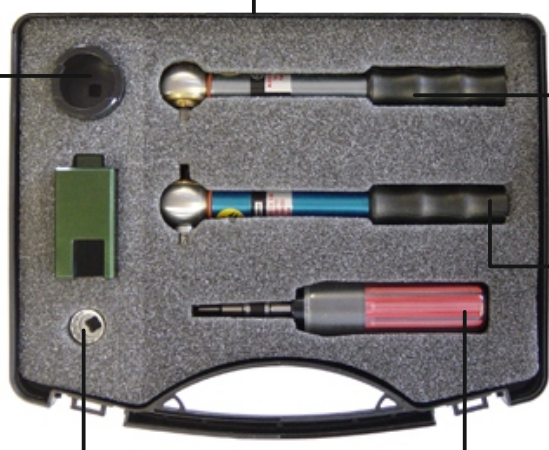

Turned Socket



Inflation Adaptor

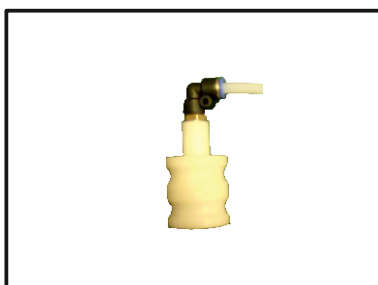

Pressure Measuring Adaptor



Calibrated Socket Driver (Tighten Cylinder)



Calibrated Socket Driver (Remove & Replace Locking Nuts For UML & HR)



Calibrated Torque Driver (Schraeder Valve)

3.1 Unpacking

- 3.1.1 First unfasten the main front zip then unfasten the spiral zip, exposing the operating head and cylinder. Care should be taken not to snag the firing line. See Fig 3.1.

WARNING: All defects should be noted onto the service record sheet.

- 3.1.2 Remove the operating mechanisms.

3.1.2.1 Following unpacking refer to:

a.) Manual Operation: Fig 3.2 - Halkey Roberts operating head removal.

b.) Automatic Operation: Fig 3.3 - Crewsaver Mk5 Automatic operating head.

c.) Automatic Operation: Fig 3.4 - United Moulders Mk5i Automatic operating head.

- 3.1.2.1.1 Automatic Only. Unscrew the Automatic Capsule if fitted from the operating mechanism. Place to one side for testing and reassembly later. See Section 6 for details.

- 3.1.2.1.2 Carefully remove the inflation cylinder by unscrewing it from the operating mechanism. Retain for further Inspection. Refer to Section 5.

- 3.1.2.1.3 Remove Operating Mechanisms (and upper and lower manifold gaskets on Halkey Roberts operating heads only) by unscrewing the retaining nut on the top of the inflation mechanism. Retain for further Inspection. Refer to Section 5.

- 3.1.3. Remove light and battery if fitted. Place to one side for further inspection. Refer to section 5.
3.1.4. For Cleaning. Refer to Section 4.
3.1.5. Carry out visual inspection. Refer to section 5.

Fig 3.2 Halkey Roberts Operating Head

Fig. 3.2.1

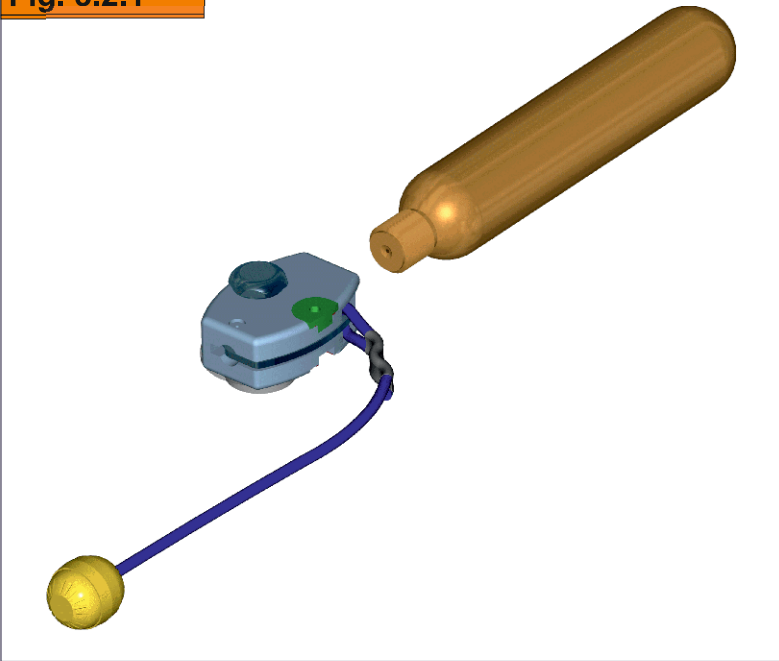

Unscrew the 33 gram cylinder from the manual firing head. Check to see if the cylinder has been used.
 NOTE: This should be performed by check weighing. If under the min. weight as displayed on the cylinder body, discard in a safe manner.

Fig. 3.2.2



Unscrew the valve retaining nut from the top of the firing head, using a 9/16" socket or spanner. Check for corrosion, discard if corroded. Remove the top sealing gasket/ washer and discard. This must be replaced with a new part upon reassembly.

Fig. 3.2.3

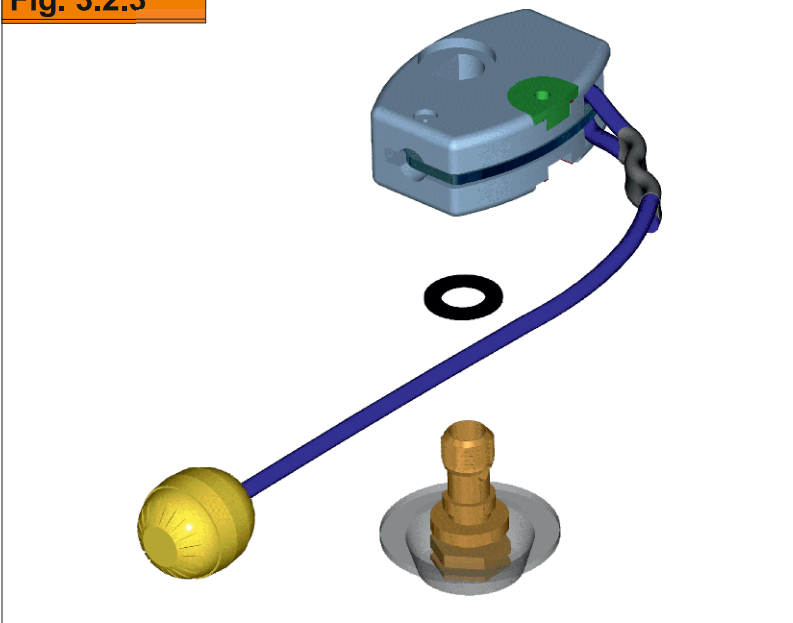

Remove the operating head from the manifold which is welded to the inflator fabric. Remove the bottom gasket / sealing washer and discard. This must be replaced with a new part upon reassembly.

Please Note: The operating head may not match the images above, but the processes are always the same.

Fig 3.4 United Moulders Mk5i Operating Head

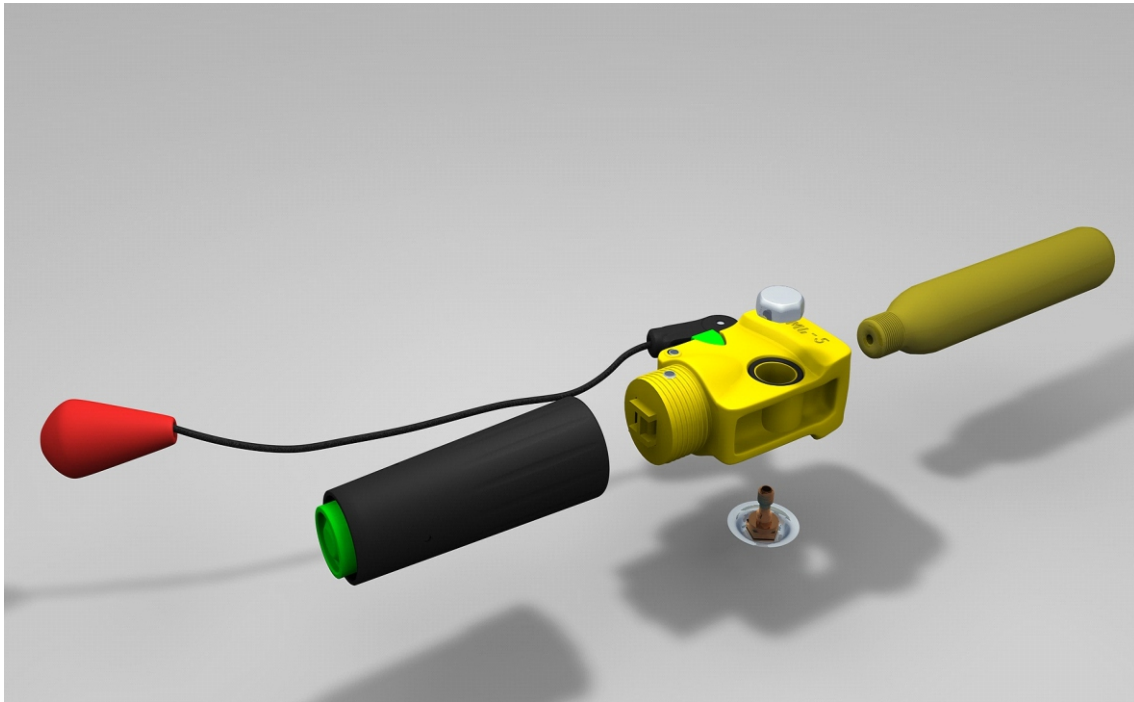

Starting in June 2010, Harvester and SWR Harvester lifejackets with Standard Auto heads will be fitted with the United Moulders Mk5i Auto Head and Mk5i Capsule illustrated above. The serial numbers of these jackets will be prefixed with the letter 'L'. Should it be necessary to change the head or the capsule of these jackets they must be replaced with the new items as shown above.

Supplies of the Crewsaver Mk5i Head and Capsule will continue to be available for fitting onto older lifejackets.

The servicing procedures for the two heads are the same with the following exceptions:

1. The top and bottom sealing 'O' rings are the same for both heads but the cylinder 'O' ring seal on the Crewsaver Mk5i head is replaced by a cutter 'O' ring on the UM Mk5i head.
2. The green retaining clips are not interchangeable.
3. It is particularly important to note that the two different Automatic Capsules are NOT interchangeable.

Fig 3.3 Crewsaver Mk5i Operating Head

Fig. 3.3.1

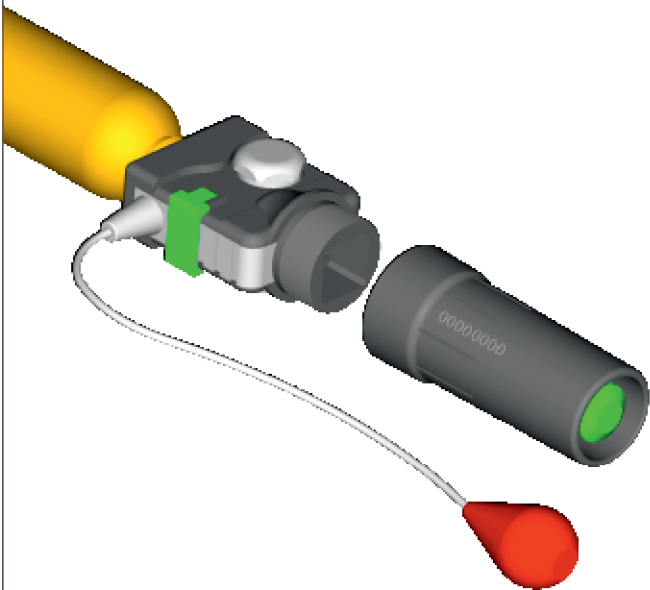

Unscrew the Automatic firing capsule from the end of the operating head. This should only be done after the test detailed in Section 6 has been performed in order to test the old unit, or if the operating head has already been fired. Check the date stamp on the cylinder and discard if expiry date is before the date of the next annual service or the capsule has been fired and replace with a new automatic firing capsule upon reassembly.

Fig. 3.3.2

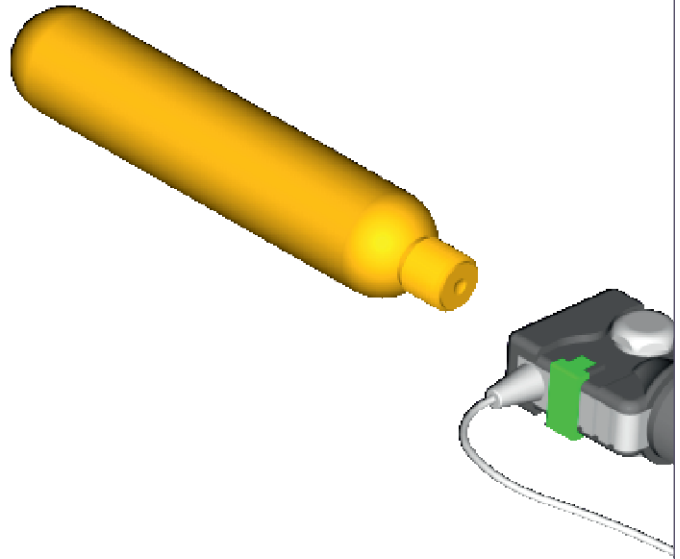

Unscrew the 33 gram cylinder from the automatic operating head. Once the cylinder has been removed inspect the cylinder O-Ring seal. Check the seal is in place and that it is in a good condition. Take the cylinder and check to see if the cylinder has been used. This should be performed by check weighing. If under the minimum weight as displayed on the cylinder body, discard in a safe manner.

Fig. 3.3.3

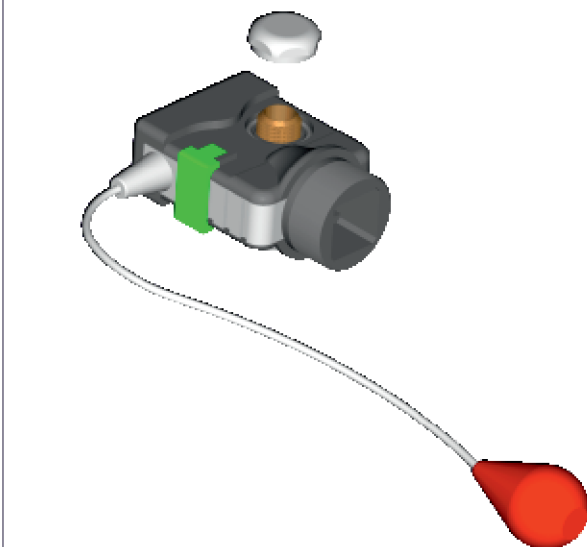

Unscrew the retaining nut from the top of the operating head. Check for corrosion and discard if corroded. Inspect the top sealing O-ring. This must be replaced with a new part if damaged.

Fig. 3.3.4

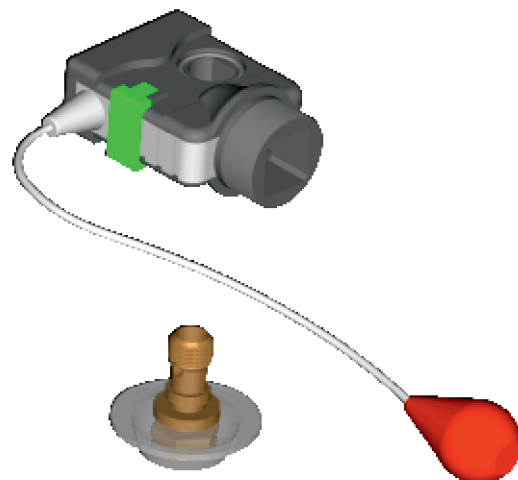

Remove the operating head from the manifold which is welded to the inflation chamber fabric. Inspect the bottom sealing O-ring. This must be replaced with a new part if damaged.

4.1 Cleaning Lifejackets

- 4.1.1 The current standard cover of the Harvester is made from a nylon fabric with a polyurethane coating that can be cleaned with care. In the event that contamination is such that the materials are inherently damaged refer to section 7.
- 4.1.2 For all types of cover, mud can be removed with clean water and the zip can be cleaned with a stiff (not wire) brush when dry.
 - 4.1.2.1 Contaminants such as oil or diesel fuel may be sponged off immediately with clean water and allowed to dry naturally.
 - 4.1.2.2 Mud can be removed with a stiff (not wire) brush when dry.
 - 4.1.2.3 Covers may be hand washed in good quality mild detergent in cool water (40°C). Rinse well, air drip dry.
- 4.1.3 Sponge the inflation chamber with PURE SOAP SOLUTION ONLY. Rinse in clean water immediately, inflate and air dry.

WARNING: Do not use proprietary cleaning fluids, thinners, spirits or similar substances.

5.1 Outer Cover Inspection

- 5.1.1 Visually inspect the cover material for wear, abrasion, pulled threads, contamination, cuts and holes.
 - 5.1.2 If necessary the cover may be washed. Refer to Section 4.
 - 5.1.3 Effect repairs if necessary and re-inspect for quality of repaired cover. Refer to Section 7.
 - 5.1.4 Carefully examine the zips and the slider for wear, broken teeth or slider and worn or fraying tape.
 - 5.1.5 If it is considered that the cover is beyond economic repair the customer shall be advised and offered a replacement lifejacket.
- NOTE: Due to the construction of this lifejacket no individual cover is available for replacement, therefore the lifejacket as a whole must be replaced.

5.2 Inflation Chamber Inspection

- 5.2.1 Visually inspect the inflation chamber material for wear, pulled threads, contamination or signs of mistreatment .
- 5.2.2 Visually inspect all welds.
- 5.2.3 Visually inspect all webbings in accordance with Section 5.7
- 5.2.4 Visually inspect the whistle and its attachment to the lifejacket for mistreatment, defects, and fraying of the cord and its attachment.
- 5.2.5 Test Lifejacket in accordance with Section 6.

5.3 Gas Cylinders

- 5.3.1 Visually examine:
 - 5.3.1.1. For Corrosion (All cylinders corroded with red rust or with visible pitting must be replaced).
 - 5.3.1.2. Pierced or damaged piercing disc.
 - 5.3.1.3. That the cylinder has the correct gas charge - 33 grams Co₂.
- 5.3.2 Check Min Weight of Cylinder against that marked on the barrel

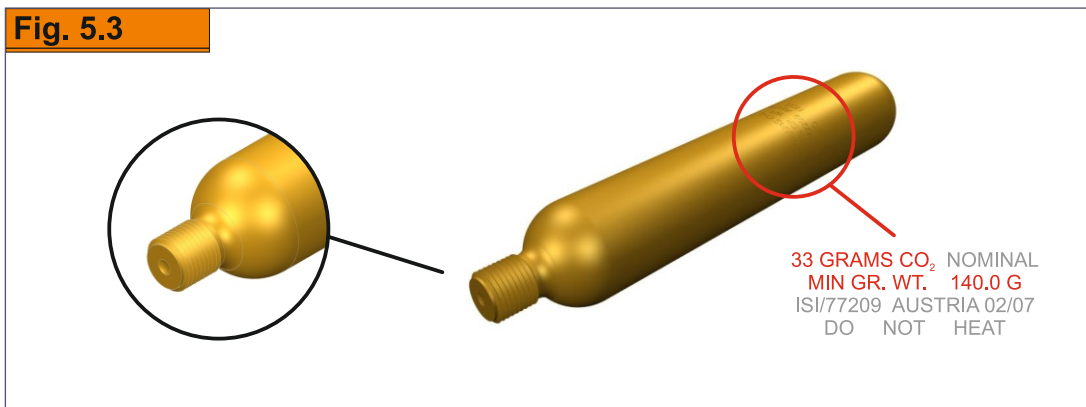

Remedial Action: If any of the above conditions are found to be incorrect the cylinder shall be replaced. See Section 9.

5.4 Mouth Inflation Valve

- 5.4.1 Visually inspect for damage.
- 5.4.2 Test in accordance with Section 6.

Remedial Action: These items are not repairable. Refer to Section 9 for replacement part.

5.5 Inflation System

- 5.5.1 Visually inspect the Operation of the Manual or Automatic Mechanism for:
 - 5.5.1.1 Operation of the Manual override lever. This shall move easily and freely.
 - 5.5.1.2 Operation of the firing pin cam action. Similarly this shall be a smooth action when the lever is operated.
 - 5.5.1.3 Firing Pin centre discharge hole clear.
 - 5.5.1.4 Activation cord for frays and damage.
 - 5.5.1.5 Moulded body for cracks and damage. Special attention to be given to the areas around the operating lever/body connection pin.
 - 5.5.1.6 Check the Automatic plunger (Automatic Head Only) at the base of the unit when depressed moves the firing pin and that the plunger and the firing pin return to their original positions when released.

Remedial Action: In the event that the Operating Mechanism fails any of the above inspection procedures, the complete unit shall be replaced. No Repairs are allowed. Refer to Section 9 for the part number of the relevant replacement part.

- 5.5.2 Visually inspect the Operation of the Automatic Capsule on the automatic Operating Head:
 - 5.5.2.1 Check plug is in place at the base of the capsule.
 - 5.5.2.2 New Capsules are to be fitted where the expiry date is before the next annual service of the lifejacket. E.g. capsules marked 'Replace by 2010' expire at the end of 2010.
 - 5.5.2.2.1 If the capsule is to be replaced – Re-fit the old capsule and carry out operational tests. Refer to section 6.

5.6 Buoyancy Foam

- 5.6.1 Remove the front and back foam panels. Check that the surface of the foam is intact and free from large areas of permanent set deformation. Check for uniformity of shape. Check the integrity of the foam - there should be no cuts or tears.
- 5.6.2 Test in accordance with Section 6.

5.7 Webbings

- 5.7.1 Visually inspect for damage:
 - 5.7.1.1. Fraying
 - 5.7.1.2. Pulled Threads
 - 5.7.1.3. Broken Stitches

Remedial Action: Effect repairs in accordance with the Repair Procedures within the limits defined in Section 7.

5.8 Buckles

- 5.8.1 Visually inspect all buckles used on the webbings for signs of damage or corrosion.

Remedial Action: No repairs are allowed. In the case of damage being found, return the Lifejacket to Crewsaver.

5.9 Labelling/Markings

- 5.9.1. Check all Markings and Labelling are clear and legible.

Remedial Action: No repairs are allowed. In the case of damage being found, return the Lifejacket to Crewsaver.

5.10 Lights (if fitted)

- 5.10.1 There are many lights available and all have a means of testing the light. Each light will have an expiry date printed on the light. Below is the example of an L6 light (with manual operation) and a description on testing.

- 5.10.1.1 Inspect the light for any signs of damage. If there are chips or cracks the light must be replaced.

- 5.10.1.2 Check that the light is securely attached to the lifejacket

- 5.10.2 To test this unit to ensure the light is working correctly:

- 5.10.2.1 Press the manual activation point (B) Figure 5.2. This will activate the light which should start to blink

- 5.10.2.2 Return it to its original position by pushing the activation lanyard, Figure 5.3. This will turn the light off.



Figure 5.1

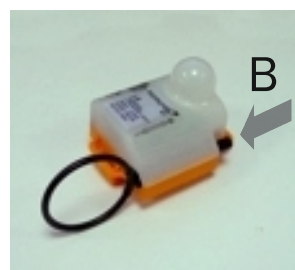

Figure 5.2



Figure 5.3

- 5.10.3 Check the expiry date (Fig. 1) and replace light if necessary.

- 5.10.4 These lights are not repairable; if the light fails inspection it must be replaced.

- 5.10.5 If the light has to be replaced it must be replaced by a CSL Light.

5.10 Lights (if fitted)

5.10.6 More recent jackets may be fitted with the Crewsaver CSL Water Activated Light.

Visually inspect the light for signs of damage to:

- 5.10.6.1. The switch.
- 5.10.6.2. the cable.
- 5.10.6.3. the lens and its mounting or housing.

5.10.7 Check expiry date on battery. The expiry date must exceed the date of the next annual service. If the light has expired or expires before the next service then it must be replaced. (See Section 9).

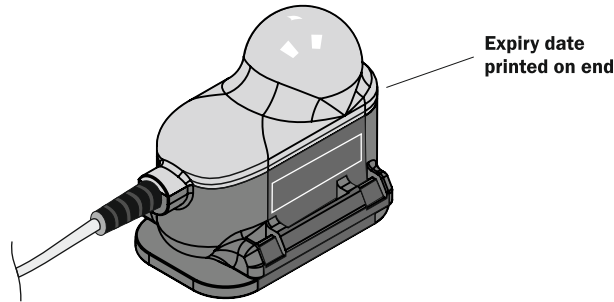

5.10.8 Ensure that the switch is in the Auto-on position.

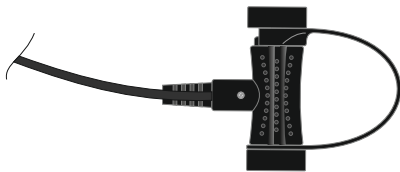

Water activated switch in Auto-on position (Earlier models)

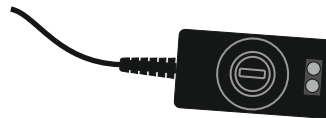

Water activated switch in Auto-on position (Later models)

5.10.9 Test the assembly as detailed in Section 6

6.1 Inflation Chamber

6.1.1. Air Holding Test.

- 6.1.1.1 Connect through a suitable Tee piece and adaptor, the oral tube with the oral valve in the open position, to a graduated water manometer (or a similar digital device for measuring back pressure).
- 6.1.1.2 Slowly inflate the lifejacket from a regulated supply until manometer reads 200mbar

Warning: Regulated supply pressure must not exceed 20psi.

- 6.1.1.3 Close off the air supply and leave for 10 minutes to ensure pressure is stable.
- 6.1.1.4 Check and record the pressure and temperature reading on the Service Record Sheet.
- 6.1.1.5 Leave for 30 minutes.
- 6.1.1.6 Check and record the pressure and temperature reading on the Service Record Sheet.

The maximum difference in the two pressure readings (pressure drop) allowed is 10%. The temperature differential shall be within plus or minus 3 degrees of the original reading. For each degree Centigrade rise in temperature subtract 2.5 mbar. For each degree Centigrade drop in temperature add 2.5 mbar to the readings to obtain the actual pressure variation. Should the temperature variation be outside 3 degrees either way then the test shall be repeated.

PSI	mH ₂ O	mHg	mm/H ₂ O	mm/Hg	kg/cm ₂	bar	mbar	Pa	kPa
1.0	27.71	2.036	703.1	51.75	0.0703	0.0689	68.95	6895	6.895
1.1	30.48	2.240	773.4	56.93	0.0773	0.0758	75.85	7585	7.585
1.2	33.25	2.443	843.7	62.10	0.0844	0.0827	82.74	8274	8.274
1.3	36.02	2.647	914.0	67.28	0.0914	0.0896	89.64	8964	8.964
1.4	38.79	2.850	984.3	72.45	0.0984	0.0965	96.53	9653	9.653
1.5	41.57	3.054	1054.7	77.63	0.1055	0.1034	103.43	10343	10.34
1.6	44.34	3.258	1125.0	82.80	0.1125	0.1102	110.32	11032	11.03
1.7	47.11	3.461	1195.3	87.98	0.1195	0.1171	117.22	11722	11.72
1.8	49.88	3.665	1265.6	93.15	0.1265	0.1240	124.11	12411	12.41
1.9	52.65	3.868	1335.9	98.33	0.1336	0.1309	131.01	13101	13.10
2.0	55.42	4.072	1406.2	103.50	0.1406	0.1378	137.90	13790	13.79
2.1	58.19	4.276	1476.5	108.68	0.1476	0.1447	144.80	14480	14.48
2.2	60.96	4.479	1546.8	113.85	0.1547	0.1516	151.69	15169	15.17
2.3	63.73	4.683	1617.1	119.03	0.1617	0.1585	158.59	15859	15.86
2.4	66.50	4.886	1687.4	124.20	0.1687	0.1654	165.48	16548	16.55
2.5	69.28	5.090	1757.8	129.38	0.1758	0.1723	172.38	17238	17.24
2.6	72.05	5.294	1828.1	134.55	0.1828	0.1791	179.27	17927	17.93
2.7	74.82	5.497	1898.4	139.73	0.1898	0.1860	186.17	18617	18.62
2.8	77.59	5.701	1968.7	144.90	0.1968	0.1929	193.06	19306	19.31
2.9	80.36	5.904	2039.0	150.08	0.2039	0.1998	199.96	19996	20.00
3.0	83.13	6.108	2109.3	155.25	0.2109	0.2067	206.85	20685	20.69
3.1	85.90	6.312	2179.6	160.43	0.2179	0.2136	213.75	21375	21.37
3.2	88.67	6.515	2249.9	165.60	0.2250	0.2205	220.64	22064	22.06
3.3	91.44	6.719	2320.2	170.78	0.2320	0.2274	227.54	22754	22.75
3.4	94.21	6.922	2390.5	175.95	0.2390	0.2343	234.43	23443	23.44
3.5	96.99	7.126	2460.9	181.13	0.2461	0.2412	241.33	24133	24.13
3.6	99.76	7.330	2531.2	186.30	0.2531	0.2480	248.22	24822	24.82
3.7	102.53	7.533	2601.5	191.48	0.2601	0.2549	255.12	25512	25.51
3.8	105.30	7.737	2671.8	196.65	0.2671	0.2618	262.01	26201	26.20
3.9	108.07	7.940	2742.1	201.83	0.2742	0.2687	268.91	26891	26.89
4.0	110.84	8.144	2812.4	207.00	0.2812	0.2756	275.80	27580	27.58
4.1	113.61	8.348	2882.7	212.18	0.2882	0.2825	282.70	28270	28.27
4.2	116.38	8.551	2953.0	217.35	0.2953	0.2894	289.59	28959	28.96
4.3	119.15	8.755	3023.3	222.53	0.3023	0.2963	296.49	29649	29.65
4.4	121.92	8.958	3093.6	227.70	0.3093	0.3032	303.38	30338	30.34
4.5	124.70	9.162	3164.0	232.88	0.3164	0.3101	310.28	31028	31.03
4.6	127.47	9.366	3234.3	238.05	0.3234	0.3169	317.17	31717	31.72
4.7	130.24	9.569	3304.6	243.23	0.3304	0.3238	324.07	32407	32.41
4.8	133.01	9.773	3374.9	248.40	0.3374	0.3307	330.96	33096	33.10
4.9	135.78	9.976	3445.2	253.58	0.3445	0.3376	337.86	33786	33.79
5.0	138.55	10.180	3515.5	258.75	0.3515	0.3445	344.75	34475	34.48
5.1	141.32	10.384	3585.8	263.93	0.3585	0.3514	351.65	35165	35.16
5.2	144.09	10.587	3656.1	269.10	0.3656	0.3583	358.54	35854	35.85
5.3	146.86	10.791	3726.4	274.28	0.3726	0.3652	365.44	36544	36.54
5.4	149.63	10.994	3796.7	279.45	0.3796	0.3721	372.33	37233	37.23
5.5	152.41	11.198	3867.1	284.63	0.3867	0.3790	379.23	37923	37.92
5.6	155.18	11.402	3937.4	289.80	0.3937	0.3858	386.12	38612	38.61
5.7	157.95	11.605	4007.7	294.98	0.4007	0.3927	393.02	39302	39.30
5.8	160.72	11.809	4078.0	300.15	0.4077	0.3996	399.91	39991	39.99
5.9	163.49	12.012	4148.3	305.33	0.4148	0.4065	406.81	40681	40.68
6.0	166.26	12.216	4218.6	310.50	0.4218	0.4134	413.70	41370	41.37

6.1.1.7. If Lifejacket fails the Air holding test inspect as follows.

6.1.1.7.1 With the lifejacket inflated carefully brush or spray the surface with a weak solution of soap and water or alternatively lower the lifejacket into a tank of water to observe for bubbles.

6.1.1.7.2 Identify and mark the source of leakage. Wash off in clean water and allow to dry naturally in air.

6.1.1.7.2.1 Special Attention to be given to:

- a) Manifold Schrader Core
- b) Oral Tube/ Top-up Valve

6.1.2 If the test is satisfactory deflate the Lifejacket in preparation for re-assembly. Refer to Section 8.

6.1.2.1. Insert the inverted oral valve dust cap into the top of the oral valve and expel the air. Lifejackets may also be deflated using the Venturi Vacuum System. For the part number, refer to Section 9.

6.1.3 Effect repairs in accordance with the Repair Procedures within the limits defined in Section 7.

6.1.4 Subsequent to remedial action being taken (see Section 7), retest the lifejacket in accordance with Section 6.

6.2 Valves

6.2.1. Oral Valves.

6.2.1.1. When removing the test adapter from each oral valve check that the oral valve reseats. If in doubt this may be checked by placing the valve underwater.

6.3 Inflation Mechanisms

6.3.1 Operational Test for Halkey Roberts Manual Operation.

6.3.1.1 Remove the operating mechanism from the lifejacket. With the cylinder also removed, pull the lever on the side of the operating head, and check that the firing pin is visibly moving inside the open end.

6.3.1.2 If the lever does not move, or the firing pin is not clearly moving, the operating head must be replaced. Refer to Section 9 for part number.

6.3.2 Operational Test for Crewsaver Mk5i Automatic Operating Heads (to be performed when capsules have expired).

6.3.2.1 Remove the operating mechanism from the lifejacket and remove the cylinder.

6.3.2.2 Assemble the expired capsule onto the body of the operating mechanism.

6.3.2.3 Place the complete unit into water and check that the unit operates within 5 seconds.

6.3.2.4 Should the mechanism fail to operate within the prescribed time thoroughly dry the unit, fit a new capsule and repeat the test.

6.3.2.5 If the mechanism fails to pass this repeat test replace the complete unit. Refer to Section 9 for part Number of the replacement part.

NOTE: all failures of this test must be reported to Crewsaver. Crewsaver may require the failed units to be returned. Please do not discard.

6.4 Retro Reflective Tape

6.4.1 If the retro reflective tape shows any signs of degradation the following tests shall be carried out in accordance with Marine Guidance Note MGN 105 (M+F) Issued by the UK Marine and Coast guard Agency March 1999.

6.4.1.1 Place a new piece of the same retro-reflective material to, and on the same plane as, a representative piece of material fitted to the appliance.

6.4.1.2 Pour water over both pieces of material.

6.4.1.3 Using a powerful torch or "Aldis" lamp held at eye level, compare the performance of the two pieces of material from a distance of 10 Metres.

6.4.1.4 If a noticeable deterioration in performance is observed then the retro-reflective material on the appliance should be replaced.

6.4.1.5 Dry off the lifejacket before repacking.

6.5 Foam Buoyancy

6.5.1 The minimum level of buoyancy required is 55N. To check the buoyancy level, remove the back and front two panels of foam. Illustrated below is a suggested method of testing the foam buoyancy. If tank facilities are not available the foam can be checked against pattern and thickness templates. These are available from Crewsaver.

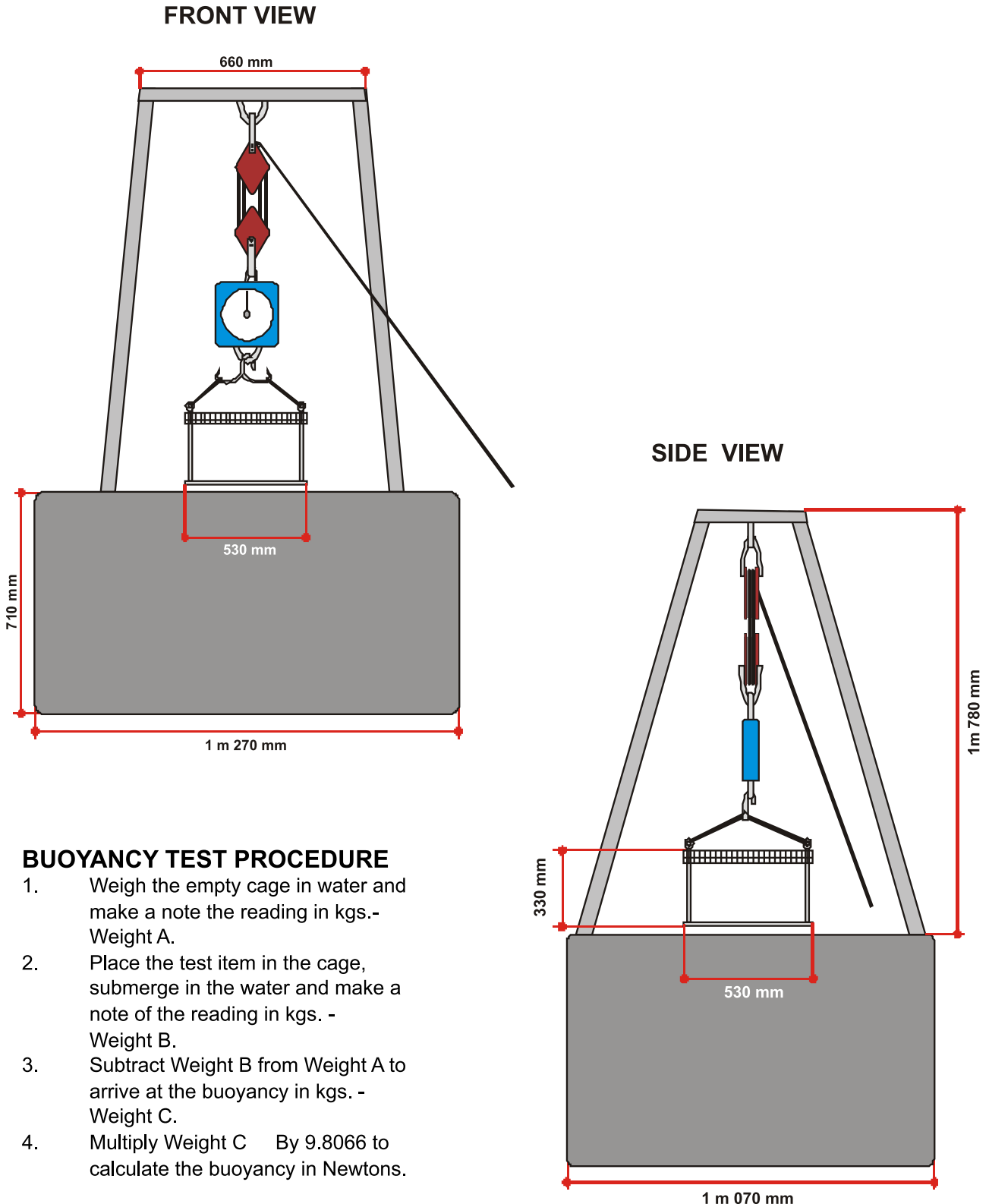

BUOYANCY TEST PROCEDURE

1. Weigh the empty cage in water and make a note the reading in kgs.- Weight A.
2. Place the test item in the cage, submerge in the water and make a note of the reading in kgs. - Weight B.
3. Subtract Weight B from Weight A to arrive at the buoyancy in kgs. - Weight C.
4. Multiply Weight C By 9.8066 to calculate the buoyancy in Newtons.

6.6 Lights and Batteries

6.6.1. Testing Procedure for lights fitted to lifejackets.

The following sea lights have been fitted to Crewsaver Commercial and Leisure lifejackets. All light units used have a detailed expiry date, after which the light should be carefully disposed of.

6.6.1.1 Daniamant L6

The Daniamant L6 can be tested using the switch located on the right side (as looked at). If necessary, replace with a Crewsaver CSL Light.

6.6.1.2 Crewsaver CSL Water Activated Light.

Test the light by immersing the sensor in water. The light must flash, remove the light from the water and dry it. The light must stop flashing. If the light does not flash the unit has expired and must be replaced.

7.1 Outer Cover

7.1.1 No repairs are allowed on the outer cover.

7.2 Inflation Chamber

7.2.1 No repairs are permitted to the inflator fabric but the complete inflator can be replaced. See Section 9 for the part number of the replacement part. The inflation chamber is attached to the outer cover by means of square links, four at the bottom of the front cover and two at the centre back, as shown on the drawings below.

7.2.2 Components attached to the inflator may be repaired in line with the limits defined below.

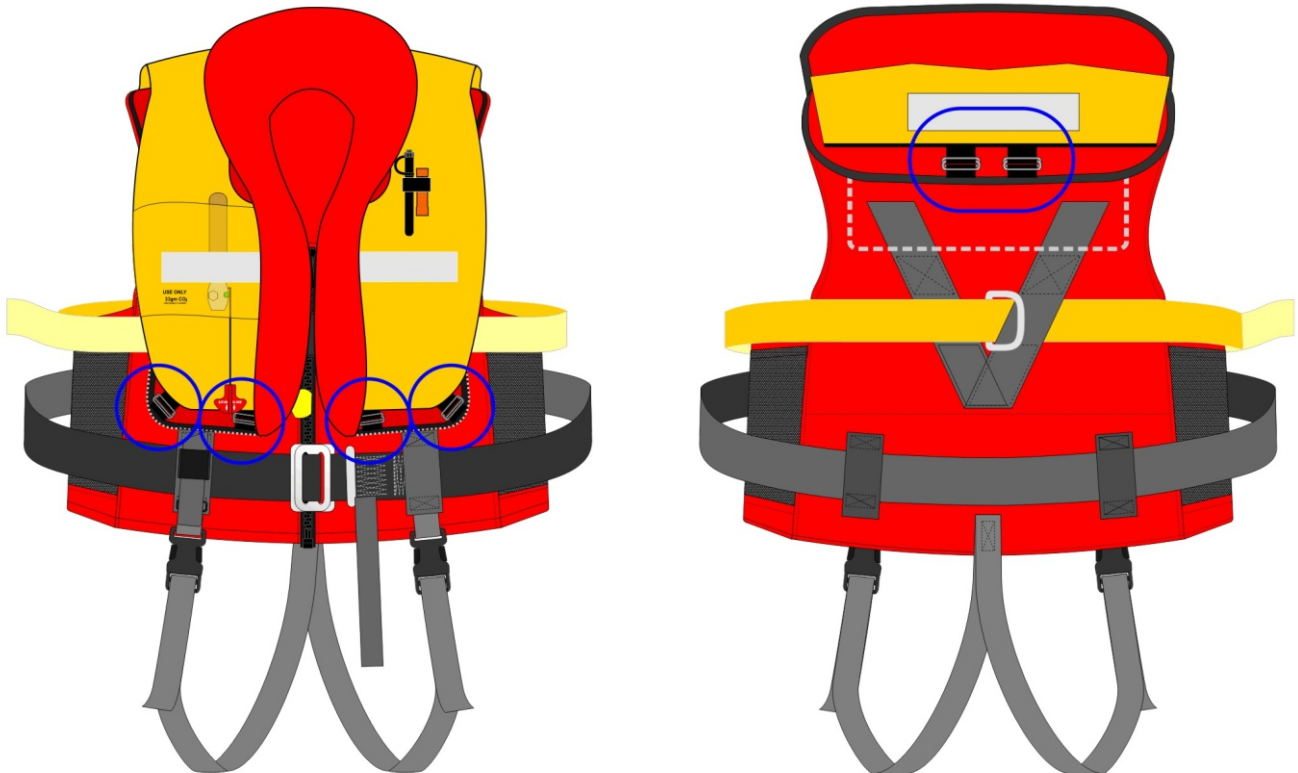

7.3 Gas Cylinders

- 7.3.1 No repairs permitted. For the Part No. of the replacement part refer to Section 9
- 7.3.2 Please ensure cylinders are disposed of in accordance with local regulations.
Treat empty cylinders as steel for recycling purposes.

7.4 Valves

- 7.4.1 No repairs permitted. For the Part No. of the replacement parts refer to Section 9
- 7.4.2 Replacement of the Oral valve may be achieved by.

7.4.2.1 Carefully removing the defective unit by applying force, with a blunt instrument, behind the oral valve. Squeeze the tube and gently push the valve out.

7.4.2.2 Push the replacement valve into the oral tube.

Fig. 7.4

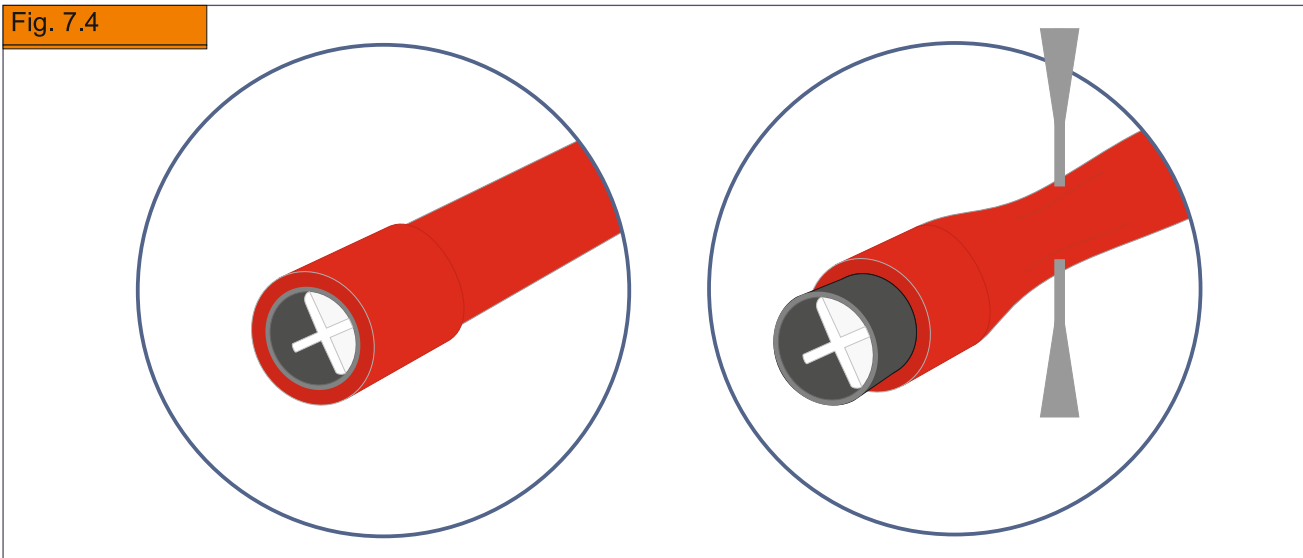

7.5 Inflation System

- 7.5.1 A Schrader core is located inside the Valve Stem.
- 7.5.1.1 Remove and replace using the calibrated torque driver for Schrader valves set to 0.32 - 0.36 Nm.
Refer to Section 9 for the Part No. of the replacement part.

WARNING: Only fit replacement Schrader valves obtained from Crewsaver.

- 7.5.2 Operating Mechanism.
- 7.5.2.1 No repairs permissible. Replace the complete unit.
Refer to Section 9 for the Part No. of the replacement part.

7.6 Webbings

- 7.6.1 No cuts are allowed in the webbing of any of these components. No repairs are permitted on Harness Lifejackets. Worn, broken or cracked stitches are to be over sewn by 25mm in each direction past the extent of the fault, use only approved thread. (Refer to Crewsaver). In the case of the Crutch Strap replace damaged unit. Refer to Section 9 for Part No. of the replacement part.

NOTE: Only pre approved stitching repairs are allowed. All persons carrying out repairs must be authorised by Crewsaver.

7.7 Buckles

- 7.7.1. These components are not repairable or replaceable. Lifejackets with damaged buckles should be returned to Crewsaver.

7.8 Repair Parameters - Stitching

All repairs to stitching must be carried out by a company deemed fit to perform the repair by Crewsaver prior to the work commencing.

- a.) Stitching repairs should be performed when the visible inspection as detailed in section 5, Para 5.7 identifies broken or pulled stitches. The following repairs may be made:
 - ai. Repairs to broken stitches should be over sewn following the same line of stitching , ensuring that the stitching continues for a minimum of 20mm past the repair section, each end must be back tacked twice.
 - aii. Repairs to pull threads should be repaired by first trimming the loose ends and then repeating the process as detailed above.
 - aiii. Any repairs carried out must be made using the correct thread available from Crewsaver. No other types of thread are to be used.
 - aiv. No stitching repairs are to be made to the inflation chamber, or parts stitched to it.
 - av. **No stitching repairs are to be made on Harness Lifejackets.**

8.1 Assembly

- 8.1.1 Ensure the whistle is positioned and tied in correctly.
 - 8.1.2 Expel the air from the chamber by inverting the dust cap on the oral tube. Lifejackets may also be deflated using the Crewsaver Venturi Vacuum System. For the part number, refer to Section 9.
 - 8.1.3 Assemble the Operating Mechanism to the inflator.
 - 8.1.3.1 For Halkey Roberts Manual Operating Mechanisms. See Fig 8.2
 - 8.1.3.1.1 A new firing retaining pin/ clip, upper and lower manifold gaskets must be fitted. Refer to Section 9 for Part Numbers.
 - 8.1.3.1.2 Fit new lower gasket.
 - 8.1.3.1.3 Locate operating head onto manifold.
 - 8.1.3.1.4 Fit new top gasket.
 - 8.1.3.1.5 Tighten the retaining nut onto the body using the Calibrated torque driver provided in the Crewsaver servicing tools. Note: Retaining nut must be tightened to between 2.5 and 2.7 Nm.
 - 8.1.3.1.6 Firmly screw the cylinder adaptor by hand into the head
 - 8.1.3.1.7 Connect the cylinder adaptor to the pressure test unit
 - 8.1.3.1.8 Pressurise the head to between 25 and 30 psi and release the control to its vertical position.
 - 8.1.3.1.9 There may be a slight decrease in pressure over the first 2 seconds as the unit stabilises. Leave for 10 seconds and check for any further decrease in pressure shown on the gauge
 - 8.1.3.1.10 Release the pressure by turning the control to deflate.
 - 8.1.3.1.11 If there had been any decrease in pressure remove the cylinder adaptor, remove the operating head and check the following.
 - a. Thick and thin washer either side of the head.
 - b. Damage to the D post seating.
 - c. Cross thread chrome nut
 - d. The cylinder seating washer.
 - e. The schrader or pang valve in the 'D' post.
 - f. The operating head
 - 8.1.3.1.12 Fit the gas cylinder to the firing mechanism by hand then check using the torque wrench (4Nm) and head adaptor from the tool kit. The operating head is gripped in one hand and the cylinder tightened using the torque wrench with the cylinder tightening tool held in the other hand.
- Warning: Care must be taken not to 'cross thread' the connection.**
- 8.1.3.2 For United Moulders Mk5i Automatic Operating Mechanisms. See Fig 8.3
 - 8.1.3.2.1 A new retaining clip must be fitted. Refer to Section 9 for replacement parts.
 - 8.1.3.2.2 Fit the new automatic firing capsule to the operating head, screw hand tight.
 - 8.1.3.2.3 Locate Operating head onto the Manifold.
 - 8.1.3.2.4 Tighten the retaining nut onto the body using the Calibrated torque driver provided in the Crewsaver servicing tools. Note: Retaining nut must be tightened to between 2.5 and 2.7 Nm.
 - 8.1.3.2.5 Firmly screw the cylinder adaptor by hand into the head
 - 8.1.3.1.6 Connect the cylinder adaptor to the pressure test unit
 - 8.1.3.1.6 Pressurise the head to between 25 and 30 psi and release the control to its vertical position.
 - 8.1.3.1.7 There may be a slight decrease in pressure over the first 2 seconds as the unit stabilises. Leave for 10 seconds and check for any further decrease in pressure shown on the gauge
 - 8.1.3.1.8 Release the pressure by turning the control to deflate.
 - 8.1.3.1.9 If there had been any decrease in pressure remove the cylinder adaptor, remove the operating head and check the following.
 - a. Thick and thin washer either side of the head.
 - b. Damage to the D post seating.
 - c. Cross thread chrome nut
 - d. The cylinder seating washer.
 - e. The schrader or pang valve in the 'D' post.
 - f. The operating head

Warning: Care must be taken not to 'cross thread' the connection.

Fig 8.2 Halkey Roberts Operating Head

Fig. 8.2.1

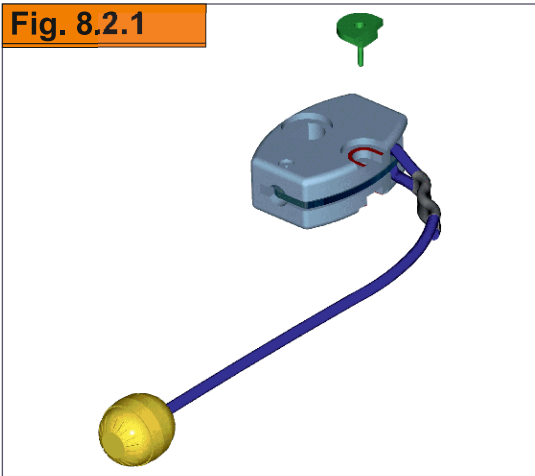

Following the inspection and testing procedures for Halkey Roberts Manual operating heads as detailed in Section 5 and 6. Fit the retaining clip or pin. Both the green retaining u-shaped clip and the green retaining pin, perform the same job, either may be fitted. The clip is fitted by pressing it over the firing arm and in to the recess either side in the centre of the operating head. The clip will click into place, thereby preventing the arm from moving. The pin is fitted by pushing down through the hole in the middle of the recess, and through the hole in the firing arm. The pin must be pushed in from the side that will be facing upwards, when the operating head is fitted on to the stole.

Once the retaining clip / pin is in place, fit the new bottom sealing washer / gasket on to the manifold. The gasket must sit flat on the manifold and lie underneath the bottom collar at the base of the manifold. Before fitting the operating head onto the manifold, check that the Schrader valve is fitted. If fitting a new Schrader valve ensure it is only finger tight. Then place the operating head onto the manifold, so that the cylinder threaded opening is facing the cylinder elastic. (away from the bottom of the inflator).

Fig. 8.2.2

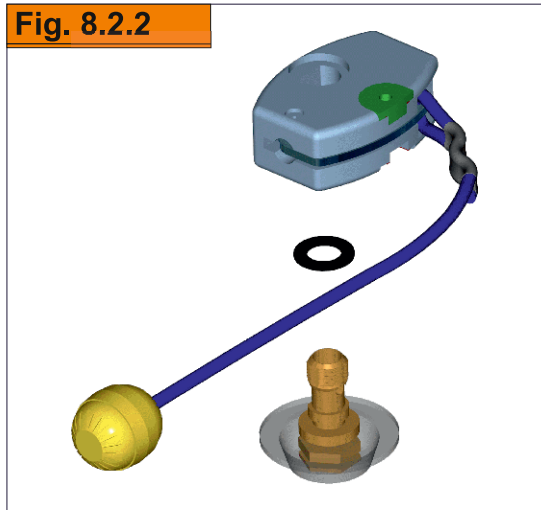

With the operating head fitted to the manifold, place the top gasket into the recess over the protruding end of the manifold. The two gaskets differ in size as shown below:-

Bottom Sealing Gasket / Washer



Top Sealing Gasket / Washer

With the top gasket in place, fit the retaining nut. The retaining nut should be screwed in to place using a torque wrench or driver fitted with a 9/16" socket. The wrench or driver should be set to between 2.5 and 2.7 Nm. This will prevent damage to the operating head and ensure a good seal is maintained.

Fig. 8.2.3

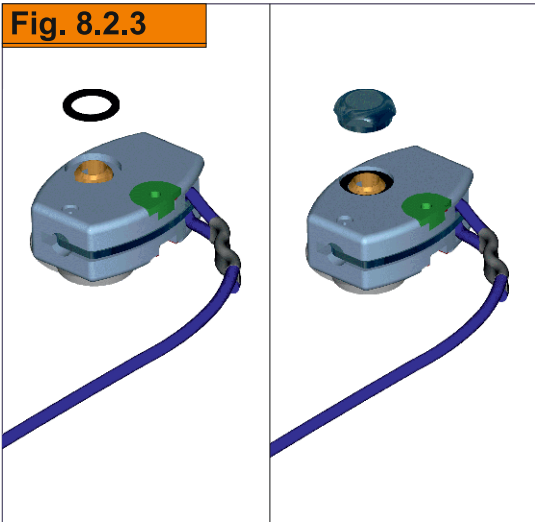

Check that the cylinder sealing gasket in the end of the operating head has been correctly fitted, or replaced if necessary. With the retaining nut fastened, fit the 33 gram CO₂ cylinder. Ensure that the cylinder has been checked weighed before fitting to the lifejacket. The cylinder should be screwed into the operating head by hand. This should be "fairly tight".

Fig. 8.2.4

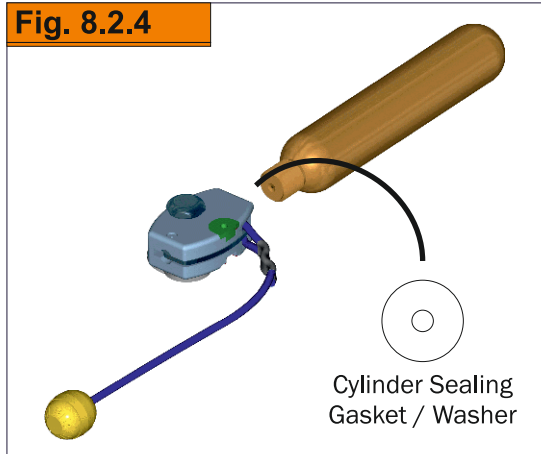

Cylinder Sealing Gasket / Washer

Fig 8.3 Crewsaver Mk5i Operating Head

Fig. 8.3.1



Fit the new firing capsule onto the operating head. The capsule should be screwed tight to the end. Make a note of the batch number and manufacture date on to the service record sheet. These firing capsules have been available in three different colours (Black, Blue and Grey).

Fig. 8.3.2

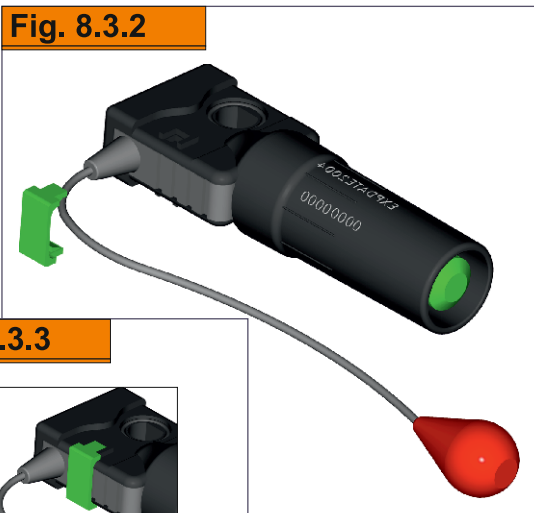

With the firing capsule fitted, fit the retaining clip. The clip is fitted by pressing it over the firing arm and in to the recess either side in the centre of the operating head. The clip will click into place, thereby preventing the arm from moving.

Fig. 8.3.3

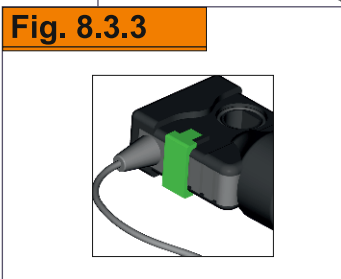

Fig. 8.3.4



Once the retaining clip / pin is in place, check the bottom o-ring seal is in place. Before fitting the operating head onto the manifold, check that the Schrader valve is fitted. If fitting a new Schrader valve use a calibrated torque driver set to 0.32 - 0.36 Nm. Then place the operating head onto the manifold, so that the cylinder threaded opening is facing away from the inflation chamber.

Fig. 8.3.5

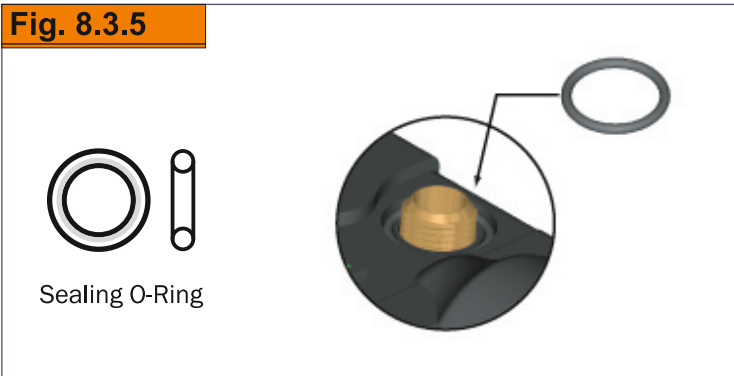

Fig 8.3 Crewsaver Mk5i Operating Head

Fig. 8.3.6

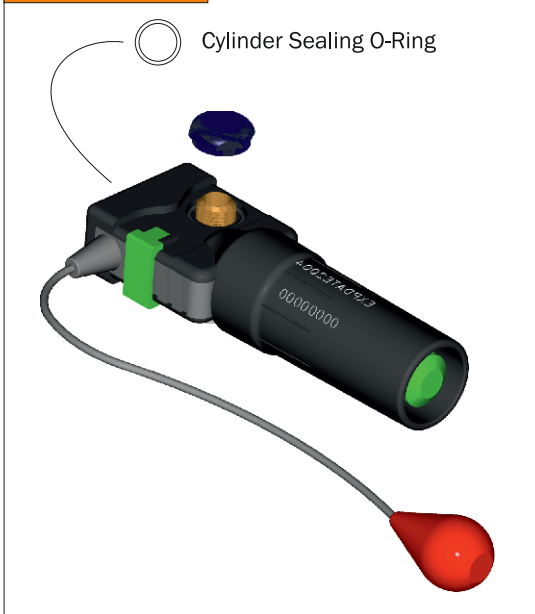
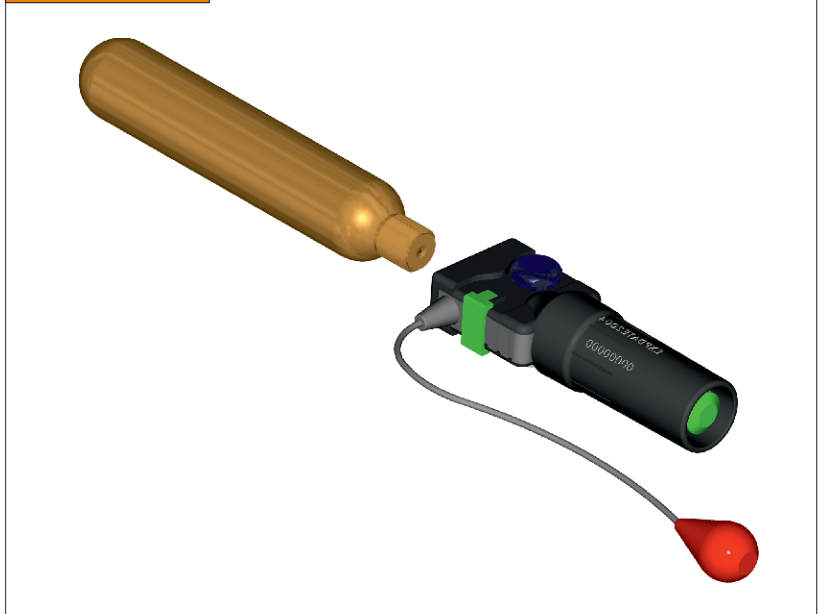

Fig. 8.3.7



Check the O-ring seal is in the recess on the top face of the operating head. With the top O-ring in place, fit the retaining nut. The retaining nut should be screwed into place using a torque wrench or driver fitted with a 9/16" socket. The wrench or driver should be set to between 2.5 and 2.7 Nm. This will prevent damage to the operating head and ensure a good seal is maintained.

Check that the cylinder sealing gasket in the end of the operating head has been correctly fitted, or replaced if necessary. With the retaining nut fastened, fit the 33 gram CO₂ cylinder (23 gram for Junior versions). Ensure that the cylinder has been check weighed before fitting to the lifejacket. The cylinder should be screwed into the operating head by hand. This should be "fairly tight".

Fig. 8.3.8

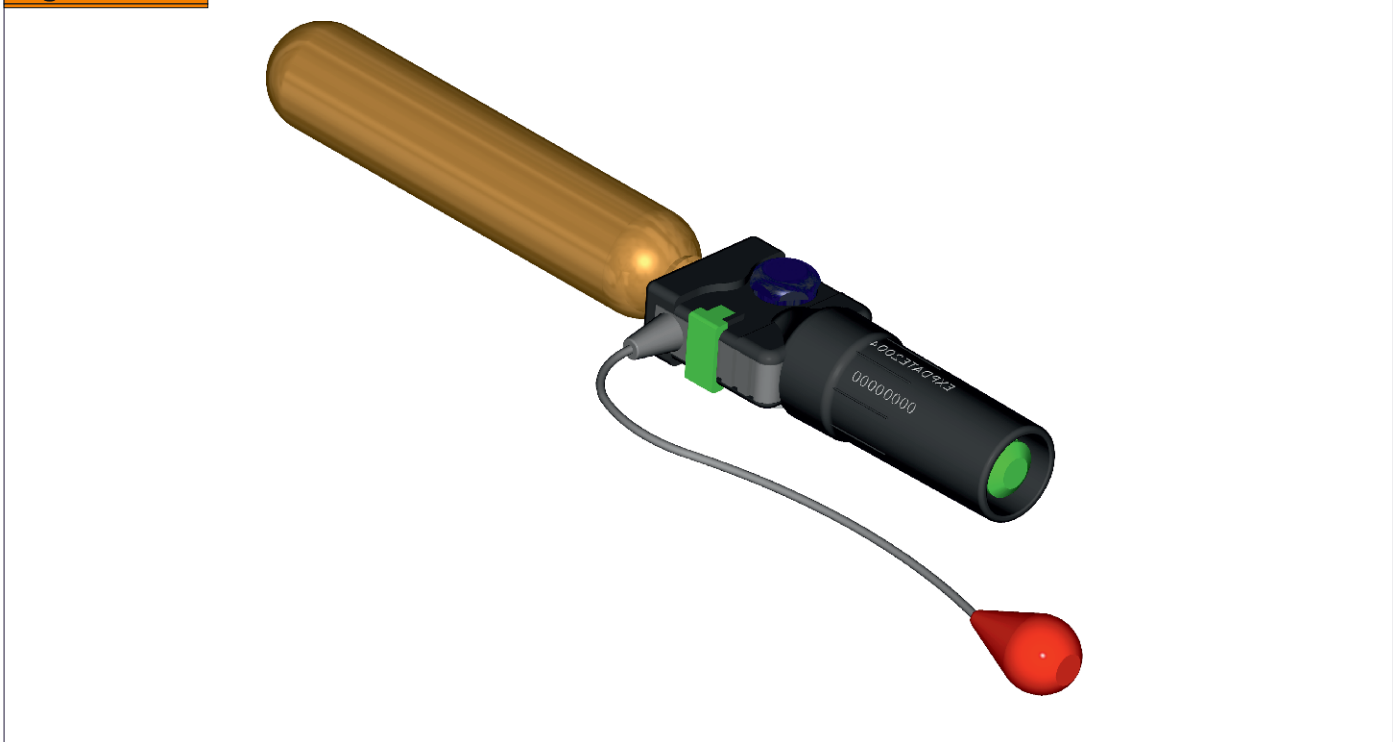
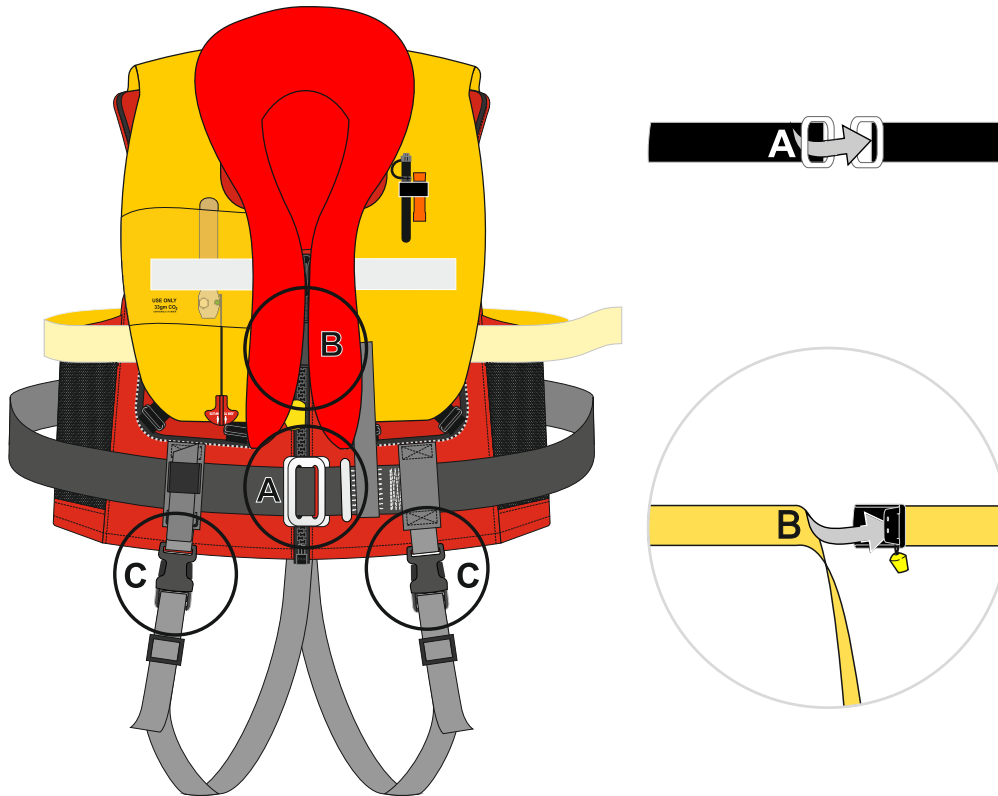

Fig 8.5.1 Harvester Packing Instructions



Fasten the Front Zip.

Thread up the harness belt and fasten the interlocking harness belt buckles (A).

Thread the quick release harness (B) through the cam buckle and fasten. (SWR version only).

Fasten the two thigh strap buckles (C) ensuring that the 25mm webbing ties are in place and correctly threaded.

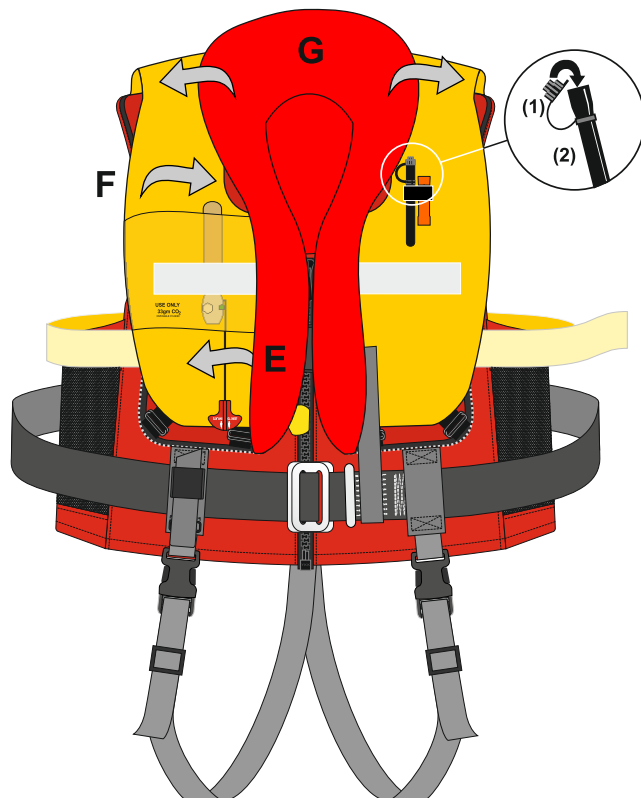

Ensure that the valve cap (1) is replaced on the inflation tube (2) after deflating the Lifejacket.

Check that the manual inflation toggle is threaded under the zip and can be seen resting by the jacket buckle.

Fold the sides (E) and (F) of the inflator over each other. Pull the cover (G) over and fasten the velcro.

Repeat the process on the other side of the jacket.

Fig 8.5.2 Harvester Packing Instructions

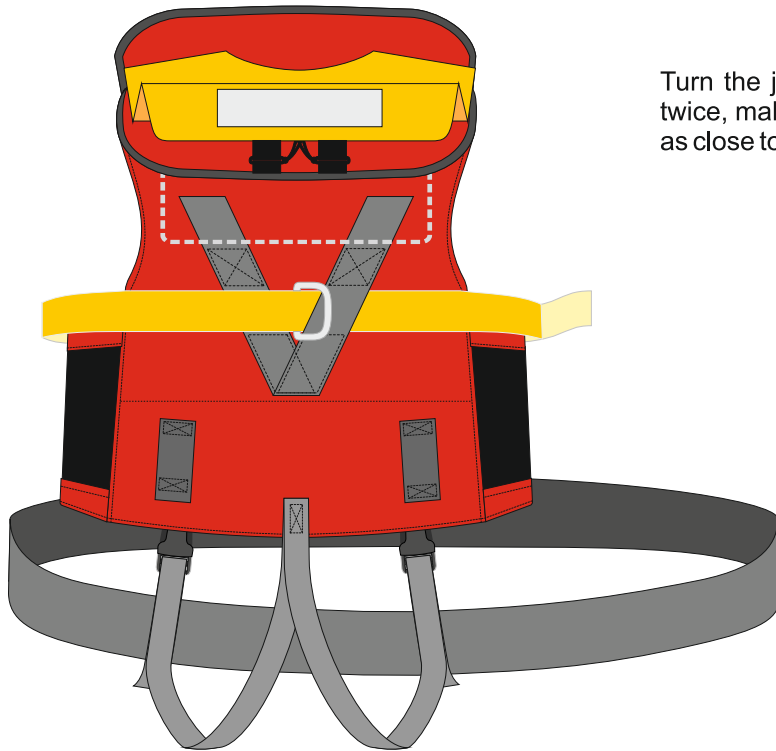

Turn the jacket over and fold the collar of the inflator twice, making sure the reflective tape is on top and it is as close to the neck as possible.

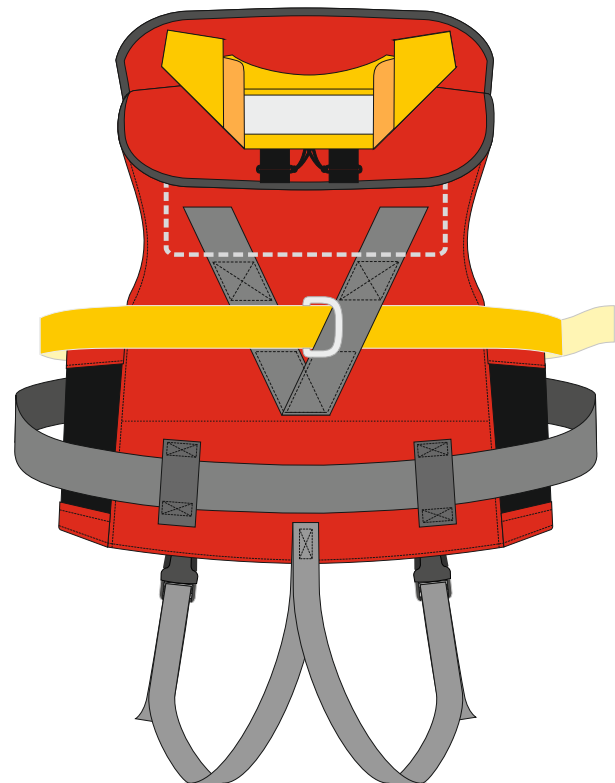

Fold the corners of the rear of the inflator down so they run into the sides of the cover. This is to ensure the narrowest part of the cover has more fullness to it. Pull the inflator cover over and fasten the velcro to keep in place.

Fig 8.5.3 Harvester Packing Instructions

Pull the inflator cover (H) over and attach the velcro on the front of the jacket only.
 Run the zip slider (Z) round the outside of the cover to (X) and back to (Y) to close the zip. As the zip passes the plastic Inflation chamber retainers check that they are threaded correctly and without obstruction. Fasten the small velcro tab over the end of the zip.
 Repeat on the other side ensuring that the lifting becket is inside the folded Inflation chamber.

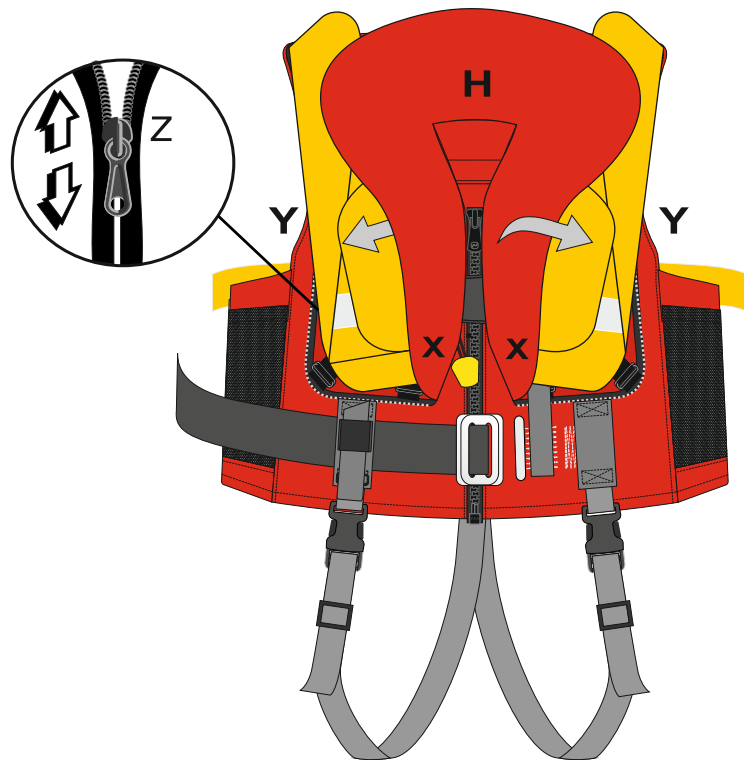

The jacket is now packed and should be placed into the red packing bag.

9.1 Parts List

Product Description	Part Number
33 gram CO ₂ Cylinder	10014
Crewsaver Mk5 Auto Capsule	10012
Halkey Roberts Manual Head	10550
Manual Head Retaining Clip	10210
Manual Head Bottom Sealing Gasket	10096
Manual Head Top Sealing Gasket	10097
Manual Head Cylinder Sealing Gasket	10382
Crewsaver Mk5i Automatic Head	10205
Crewsaver Mk5i Auto Head Retaining Clip	10111
Auto Head Sealing Gasket (Top and Bottom)	10373
Crewsaver Mk5i Auto Head Cylinder Sealing Gasket	10381
UM Mk5i Auto Head	11044
UM Mk5i Auto Capsule	11042
UM Mk5i Auto Head Retaining Clip	11043
UM Mk5i Auto Head Cutter 'O' Ring	11048
Whistle	10677
CSL Light	10226
Mouth Inflation Valve	10209
Mouth Inflation Valve Cap	10151
Schrader Valve	10049
Replacement Inflator	10384
50mm Self Adhesive Retro reflective Tape	R47700
Retaining Nut	11047
Venturi Vacuum System	10481
Servicing tool kit	10467
Cylinder adaptor for back pressure System	900032
Back pressure test unit	900031
Cylinder tightening tool	900030