



Crewsaver®

SERVICE MANUAL

SEACREWSADER 275 TWIN CHAMBER LIFEJACKET

Crewsaver®

Survitec House, Lederle Lane, Gosport,
Hants. PO13 0FZ, England.
Tel: +44 (0) 1329 820000 Fax: +44 (0) 1329 236218
email: crewsaver@survitecgroup.com
Web: www.crewsaver.com

 **survitecgroup**

Service Bulletin and Amendments Register

No.	Description	Date
26	Seacrewsader packing	June 2009
27	Seacrewsader pull cords	23-06-09
Page 4	Add description to Hermetically seal bags - Sampling plan	3-07-09
Page 28	Add - warning do not use vacuum to deflate as it may damaged the oral tube valves	3-07-09
Page 32-34	Update packing diagrams to show new packing method	3-07-09
Page 7 & 8	Drawings added of Seacrewsader with Harness & Cowtail (PGS)	July 2009
Section 2	Servicing Schedule: Pressure Test Results Section amended Similar Record Sheets containing the same information may now be used.	Nov 2010
Section 6.1	Point 6.1.1.5 - inflation time amended from 60 to 30 min. Point 6.1.2 - Pressure relief valve operates at 1.5 psi.	Nov 2010
Section 6.2	Point 6.2.3 added regarding replacement of Schraeder valve.	Nov 2010
Section 6.3	If the operating mechanism fails to operate using the expired capsule it is no longer required to repeat the test using a new capsule.	Nov 2010
Section 6.5	Tests on the retro-reflective tape to be carried out only if there are signs of degradation.	Nov 2010
Section 7.6	Schraeder valves to be replaced using a torque driver set to 0.32 - 0.36 Nm. Wording to Fig 8.2.4 amended accordingly.	Nov 2010
Section 8.1	Point 8.1.3 - revised procedure for re-fitting automatic operating head.	Nov 2010
Section 8.2	Fig. 8.2.1 - Fig. 8.2.7 - revised procedure for re-fitting automatic operating head.	Nov 2010
Section 9.1	Parts list revised	Nov 2010

Service Bulletin and Amendments Register

No.	Description	Date
Issue 6	Section outlining the scope of the Manual added on Index page.	June 2011
Issue 7	Page 5 - change in procedure for accessing manuals on the website. Section 5.4 and 6.4 - Details of CSL Light added. Expired L6 Lights to be replaced by CSL Lights. CSL Light added to Parts List.	May 2014



Scope

This manual covers the servicing of the Seacrewsader 275N Twin Chamber lifejacket including the PGS Seacrewsader with Harness and Cowtail.

Index

Section 1	1.1	Introduction
	1.2	Product Description
	1.3	Data Sheet
	1.4	General Features
Section 2	2.1	Service Station Guidelines
	2.2	On Receipt Inspection
	2.3	General Care
	2.4	Servicing Tools
	2.5	Lifejacket Servicing Record Sheet
Section 3	3.1	Unpacking the Lifejacket
Section 4	4.1	Cleaning Lifejackets
Section 5	5.1	Inspection
Section 6	6.1	Testing
Section 7	7.1	Repairs
Section 8	8.1	Assembly
Section 9	9.1	Replacement parts
Section 10	10.1	Service Bulletins

1.1 Introduction

- 1.1.1. This Service Manual will be published on the Crewsaver website (www.crewsaver.com). Click on PARTNER AREA/LOGIN at the top of the screen. Personnel who have been trained in the servicing procedures for this lifejacket will be issued with a Username and Password to enable them to access the download section. Each manual carries an Issue Number and records of issue are logged by Crewsaver to ensure that the service network maintains correct and up to date servicing information. Emails will be sent regarding any new Issues. Periodically service bulletins may be issued which will be published on the Crewsaver website (www.crewsaver.com). Emails will also be sent. It is the service station's responsibility to regularly check the website for any new bulletins and to ensure inclusion within the servicing manual. The service bulletin register at the front of the Manual should be completed.
- 1.1.2. The information referenced in each section, follows a standard servicing procedure by which the inspection should take place.
- 1.1.3. This servicing manual details information to enable regular maintenance and servicing of the lifejacket to help prolong the life of the product and ensure it functions correctly.
- 1.1.4. The manual should be used as a reference document following training in servicing procedures instructed by Crewsaver approved personnel. The manual also details the equipment and parts needed for correct maintenance to be performed.
- 1.1.5. Servicing must be carried out annually by a Service Station authorised by the manufacturer. 
- 1.1.6. This product is available in Hermetically sealed bags, extending the service life to 5 years. 
- 1.1.7. Regular servicing is to be carried out by qualified personnel trained by Crewsaver and holding a valid servicing certificate. Certificates are valid for a period of 3 years.

1.2 Product Description

- 1.2.1. The Seacrewsader is a twin chamber 275N inflatable lifejacket.
- 1.2.2. The lifejacket is approved to both SOLAS/MED  and CE, EN 399 -275N Lifejackets.
- 1.2.3. The lifejacket is easy to don and work in whilst still retaining high in-water performance.
- 1.2.4. The buoyancy of the jacket is provided by two chambers with a 1.5 psi relief valve oral tube on each chamber to ensure the full buoyancy is achieved whether on single or double chamber inflation. This feature enables the jacket to continue to operate providing full buoyancy even in the eventuality that one of the firing heads fails.
- 1.2.5. The high buoyancy of this lifejacket allows it to be suitable when the user is wearing heavy clothing, an immersion suit or carrying tools.
- 1.2.6. This lifejacket can be inflated manually, as well as automatically when entering the water. This lifejacket has a permanent crutch strap and is fitted with a light that is operated when the lifejacket inflates. The Seacrewsader can also be supplied with a fitted spray hood that conforms to EN394.
- 1.2.7. This lifejacket comes in two different versions, the waist belt version and integral deck safety harness version which both have a zip cover closure.

1.4.1 General Features - Non-Harness

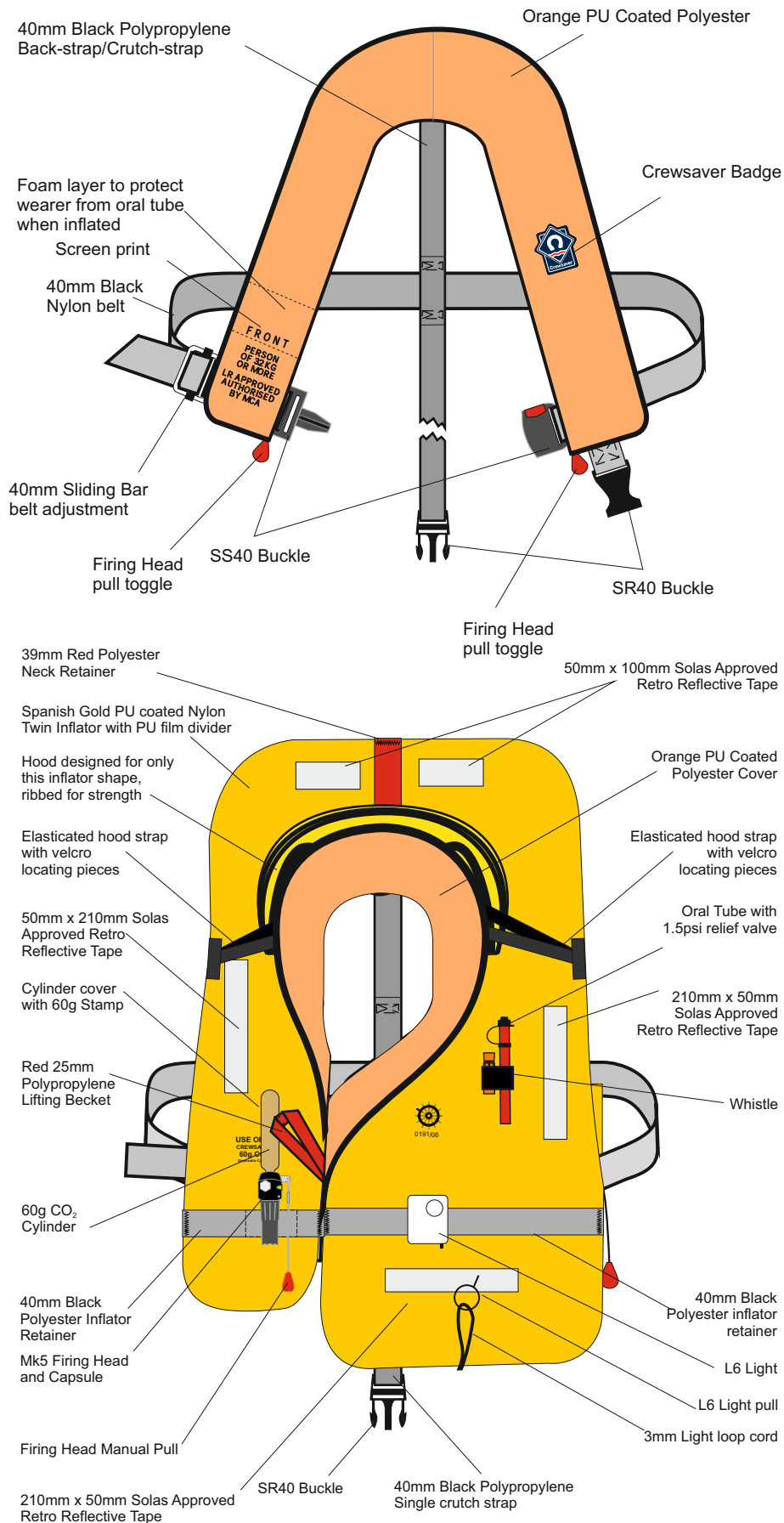

1.4.2 General Features - Harness

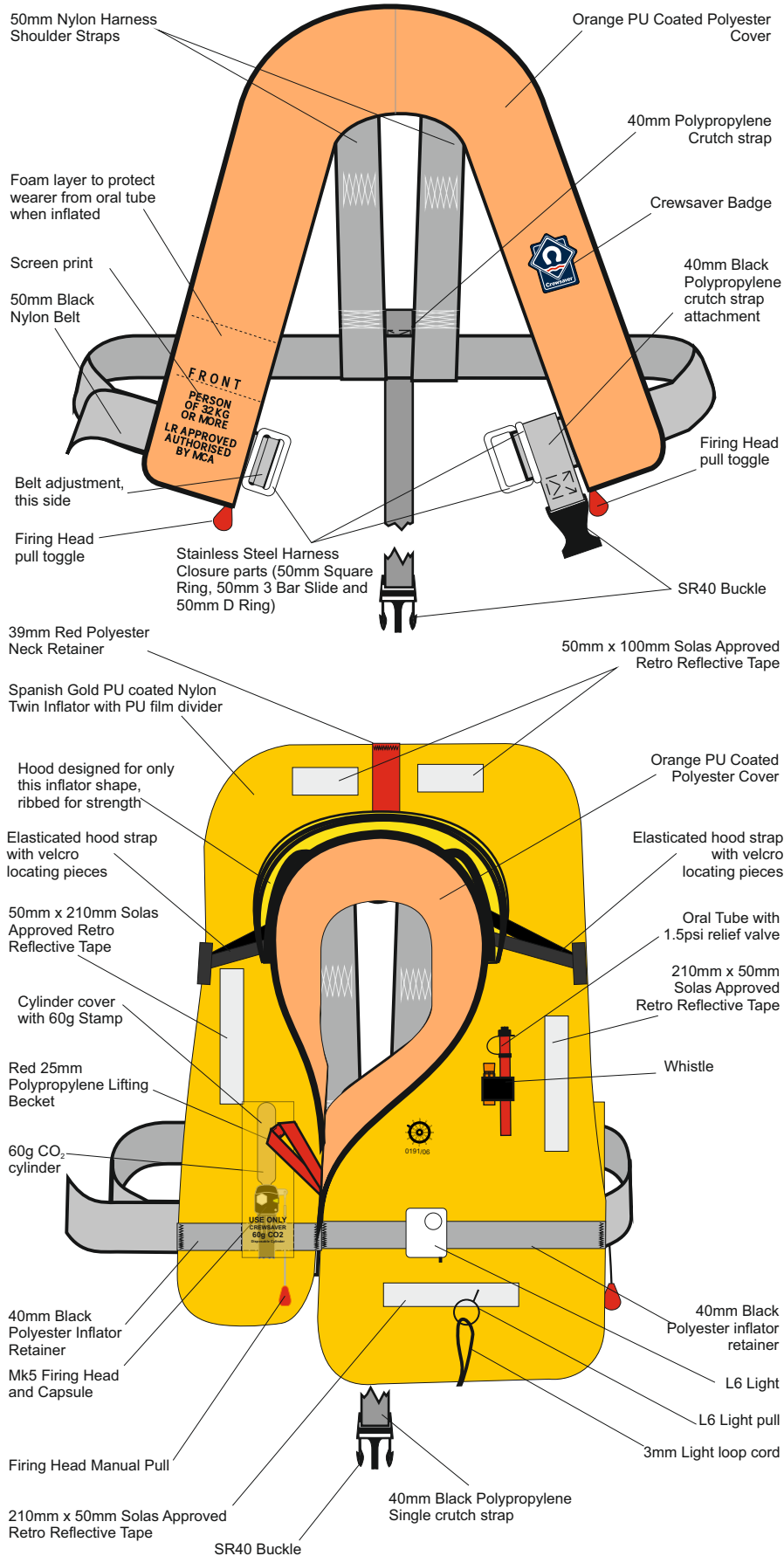

1.4.3 General Features - Harness + Cowtail

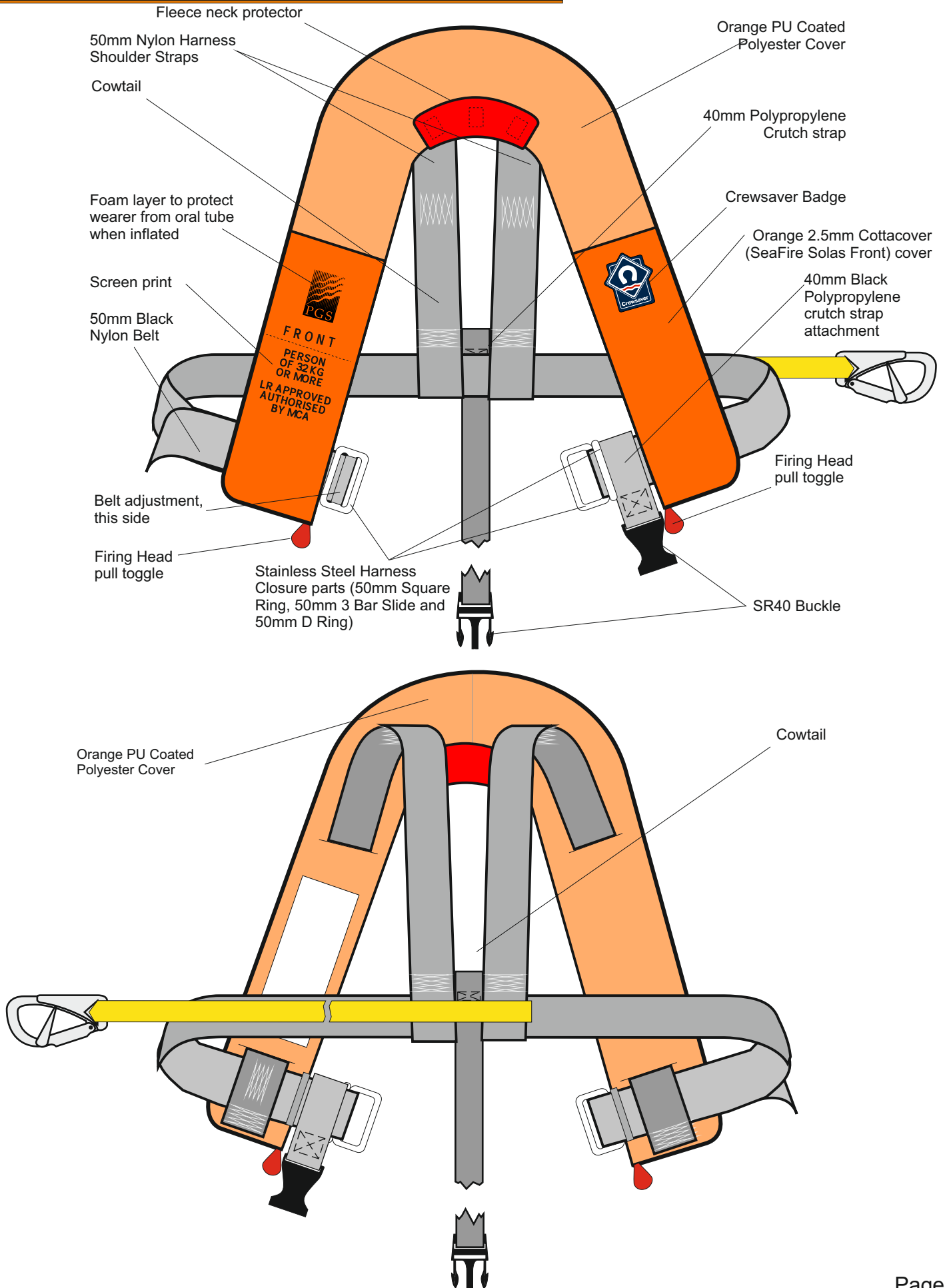

1.4.3 General Features - Harness + Cowtail

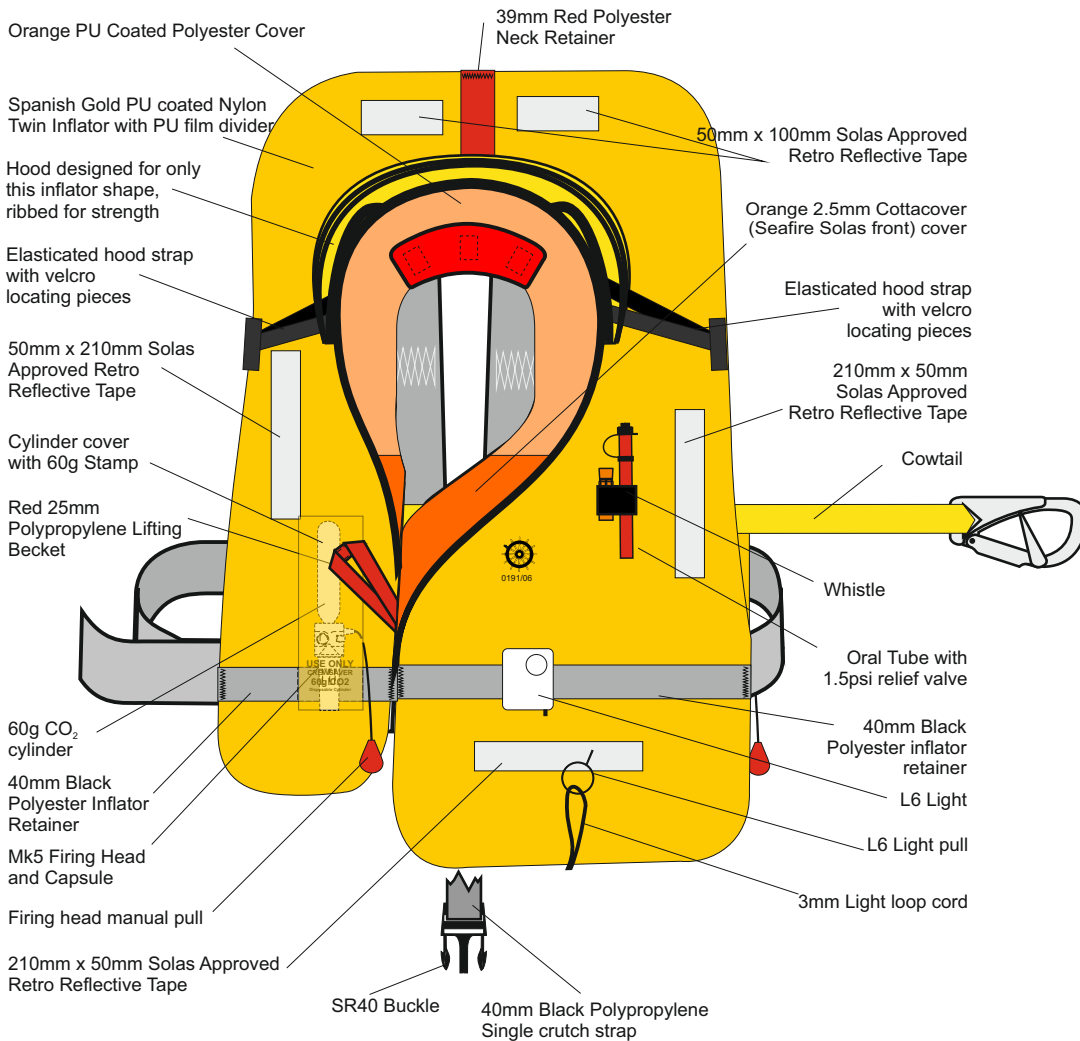

BACK

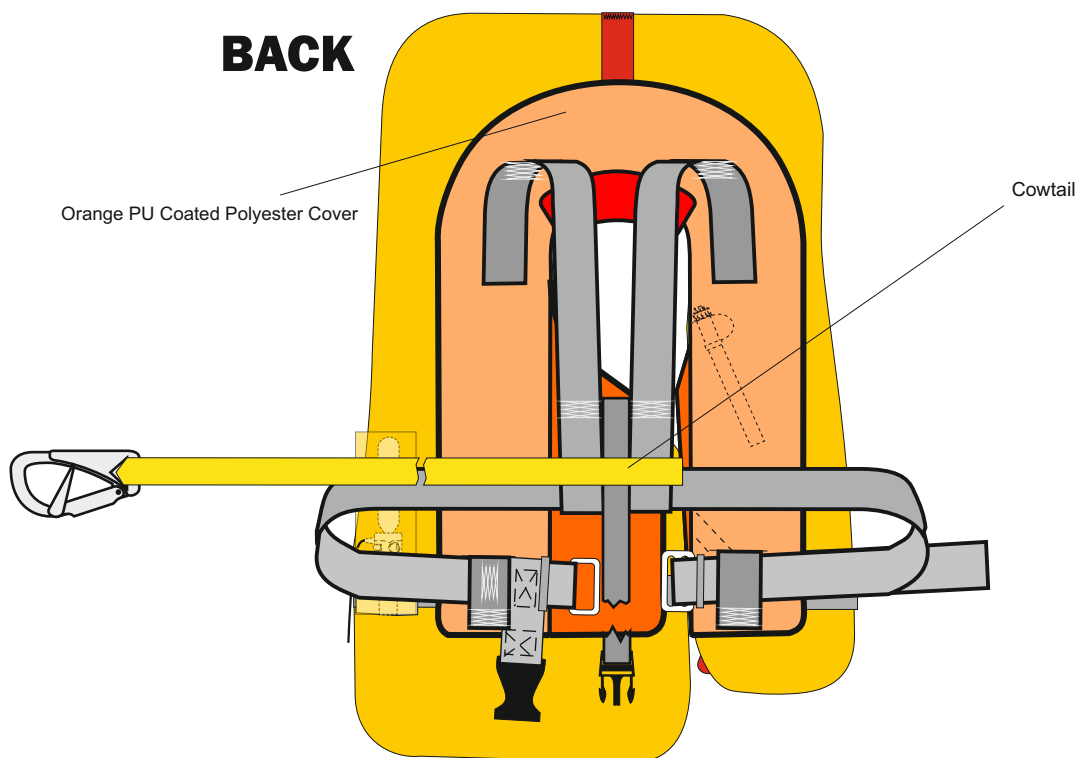

2.1 Service Stations

- 2.1.1 Service stations shall comply with the following as a minimum;
- 2.1.1.1 Servicing of Inflatable Lifejackets shall be carried out in a fully enclosed area only.
- 2.1.1.2 The area shall be well lit and protected from direct sunlight
- 2.1.1.3 The temperature and humidity shall be sufficiently controlled to ensure that the servicing of inflatable Lifejackets may be carried out successfully.
- 2.1.1.4 The area shall be efficiently ventilated but free from draught
- 2.1.1.5 Sufficient Tools (including specialist tools) shall be available to ensure Lifejackets may be disassembled, tested and reassembled in accordance with this Manual. These shall include but not be limited to:
 - 2.1.1.5.1 Manometers and pressure gauges
 - 2.1.1.5.2 Oil free and dry air supply
 - 2.1.1.5.3 Scales for weighing Gas Cylinders
 - 2.1.1.5.4 Crewsaver Service tool kit (See 2.7). This is recommended but similar calibrated devices may also be used.
- 2.1.1.6 Stock of materials and components shall be held to allow efficient servicing with readily available replacement parts to ensure a prompt service for the customer.
- 2.1.1.7 Only personnel trained and certified in accordance with Crewsaver requirements are approved to carry out Servicing and Maintenance. They must be holders of a valid Certificate issued by Crewsaver.
- 2.1.1.8 The service station shall be of an approved standard.
- 2.1.1.9 Procedures shall be introduced to ensure that service bulletins, Manuals and replacement parts are obtained from Crewsaver.
- 2.1.1.10 Subsequent to initial approval and thereafter the service station shall be subject to regular surveillance by Crewsaver.
- 2.1.1.11 The service station must comply with and have met all QA criteria in the Crewsaver servicing protocol file.

2.2 On Receipt Inspection

- 2.2.1 On receipt of the Lifejacket(s), check the state of the packaging before opening and notify the owner and the company delivering the package of any defects or damage.
- 2.2.2 On opening the package, check the contents for their general condition and quantity
- 2.2.3 Prepare Servicing Record Sheet
- 2.2.4 Visually inspect the Lifejacket cover and the inflatable chamber for damage, abrasion, contamination etc. in accordance with this manual
- 2.2.5 Note repairs or replacements required on the record sheet
- 2.2.6 Unless obvious damage is evident test the Lifejacket in accordance with Section 6. If it is considered that the damage found would cause the Lifejacket to fail the tests then corrective action shall be carried out prior to testing.
- 2.2.7 Damaged areas shall only be marked using wax based crayon. Marks shall be with a small circle or cross. Ballpoint, rollerball or other forms of ink shall not be used. If in doubt refer to Crewsaver for guidance.
- 2.2.8 Repairs to welded components including the inflatable chambers are expressly forbidden.

2.3 General Care

- 2.3.1 This automatic jacket should be stowed in accordance with the manufacturer's instructions
 - 2.3.1.1 Lifejackets should be stowed in a dry compartment. Avoid high humidity, such as a car boot.
 - 2.3.1.2 Automatic Lifejackets should have stowage facilities which are provided with a method to encourage moisture removal.
 - 2.3.1.3 Lifejackets should be stowed vertically, for example hung on hooks, in order that any trapped water or condensation can drain away naturally.
 - 2.3.1.4 Lifejackets should be rinsed in fresh water and dried thoroughly after use.

WARNING

Prior to sponging or washing remove automatic capsules from the firing mechanism. Allow to dry thoroughly afterwards.

- 2.3.2 Contaminants such as oil or diesel fuel may be sponged off immediately with clean water and allow to dry naturally.
- 2.3.3 Mud can be removed with a stiff (not wire) brush when dry.
- 2.3.4 The Lifejacket cover may be hand washed in good quality mild detergent in cool water (40°C) rinse well, drip dry naturally in air.
- 2.3.5 Sponge the inflatable chamber with pure soap solution only. Rinse in clean water immediately, inflate and allow to dry naturally in air.

WARNING

Do not use proprietary cleaning fluids, thinners, spirits or similar substances.

- 2.3.6 In cases of severe contamination the unit shall be deemed beyond economic repair and the customer advised to purchase a replacement lifejacket
- 2.3.7 Replacement Lifejackets may be purchased when permanent damage has been incurred.
- 2.3.8 It is advised that personnel are familiarised with the operation of all lifejackets and lifesaving appliances.

2.4 Lifejacket Servicing Tools

Fig. 2.4 Table of Tools Required

Description	Type
Crewsaver Servicing Tool Kit A fine screw driver or tool suitable for removing gaskets Scissors or good quality trimming shears "Chinagraph" pencil Fine point indelible pen 1 off metal calibrated metre stick Scales to weigh gas cylinders Adaptor/tee piece for the testing of inflation chambers. Manometer Timing Device Thermometer Clean and dry air supply 450mm wide bag sealer (3mm element) Suitable large area for the work to be carried out 1 off FR steel cabinet (adhesive store)	0-1000gram (+1/-1 grams) 0-500Mbar 0-40°C

2.5 Lifejacket Service Record Sheet

- 2.5.1. An electronic copy of the sheet is available to aid reproduction (or copy next page).
- 2.5.2. Each lifejacket serviced should be recorded either individually or as a batch, showing the serial numbers and the work performed during the service.
- 2.5.3. The service record sheet should be signed and a copy given to the owner certifying that the lifejacket has been serviced.
- 2.5.4. All replacement parts should be noted - recording either the serial numbers of the component or the expiry date.
- 2.5.5. The record sheet shown on the next page is a recommended version. Similar record sheets, including the same information, may also be used.



CERTIFICATE NUMBER:

W/O Number:

LIFEJACKET SERVICING SCHEDULE

TYPE	
CUSTOMER	
VESSEL	
LAST SERVICED BY	DATE OF LAST SERVICE

SERIAL NUMBER/S:

CHAMBER INSPECTION	<input type="checkbox"/> <input type="checkbox"/>	COMMENTS
GENERAL CONDITION		
MATERIAL		
WELDS		
WEBBINGS		
RETRO TAPE		
WHISTLE		
ORAL TUBES		
RELIEF VALVES		
MANIFOLDS		
SCHRAEDER VALVES		
CYLINDERS		
LIGHT		
CYALUME POCKET		
BUDDY LINE		

INFLATION MECHANISM	<input type="checkbox"/> <input type="checkbox"/>	COMMENTS
OPERATING MECHANISM		
CORD		
AUTOMATIC CAPSULE		
WASHERS		
RETAINING NUT		
RETAINING CLIP		
TOGGLE		

SPRAY HOOD	<input type="checkbox"/> <input type="checkbox"/>	COMMENTS
FABRIC		
ATTACHMENT		
VELCRO		

WEBBINGS	<input type="checkbox"/> <input type="checkbox"/>	COMMENTS
WAIST BELT / HARNESS		
BACK STRAP		
LIFTING BECKET		
CROTCH STRAP		
BUCKLES		
STITCHING		

COVER	<input type="checkbox"/> <input type="checkbox"/>	COMMENTS
MATERIAL		
VELCRO		
ZIP		
PLB POCKETS		

PRESSURE TEST RESULTS

TIME		FRONT CHAMBER	REAR CHAMBER
ON			
OFF			
TEMP.		ON	OFF

RELIEF VALVE TEST RESULTS

	FRONT CHAMBER	REAR CHAMBER
OPEN		
CLOSE		

REPAIRED ITEMS (COMMENTS)

SERVICED BY:

DATE:

2.7 Lifejacket Servicing Tool Kit

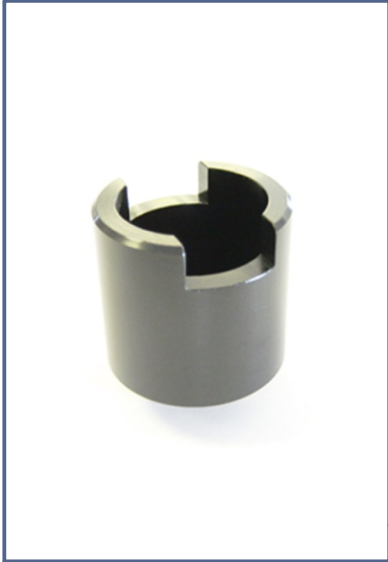

UML Mk5 Auto Socket



Calibrated Socket Driver
(Tighten Cylinder)

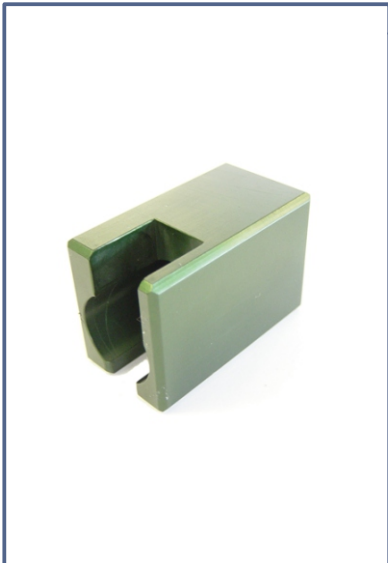

UML Mk3 Auto Socket

Turned Socket



Calibrated Socket Driver
(Remove & Replace Locking Nuts
For UML & HR)



Calibrated Torque Driver
(Schraeder Valve)

3.1 Unpacking

- 3.1.1. Starting at the operating mechanism side of the cover, unpeel the velcro and pull the zips apart, exposing the operating Mechanism and cylinder. See Fig 3.1

WARNING: Care should be taken not to snag the operating mechanism pull cord

- 3.1.2. Open the rest of the velcro and zip around the outside of the cover by peeling the fabric apart. Care should be taken not to snag the operating mechanism pull cords.

WARNING: All defects should be noted onto the service record sheet.

- 3.1.3. Remove the operating mechanisms.

3.1.3.1 For lifejackets fitted with United Moulders mechanisms refer to Fig 3.2 - Automatic Operation

3.1.3.1.1 Unscrew the Automatic capsule from the operating head. Place to one side for testing and reassembly later. See section 6.

3.1.3.1.2 Carefully remove the CO₂ cylinder by unscrewing it from the operating Mechanism. Retain for further inspection. Refer to Section 5.

3.1.3.1.3 Remove operation mechanisms by unscrewing the retaining nuts. Retain for re-assembly.

- 3.1.4. Remove light and battery. Place to one side for further inspection. Refer to section 5

- 3.1.5. For Cleaning. Refer to Section 4.

- 3.1.6. Carry out visual inspection. Refer to section 5.

Fig 3.1 Unpacking the Lifejacket

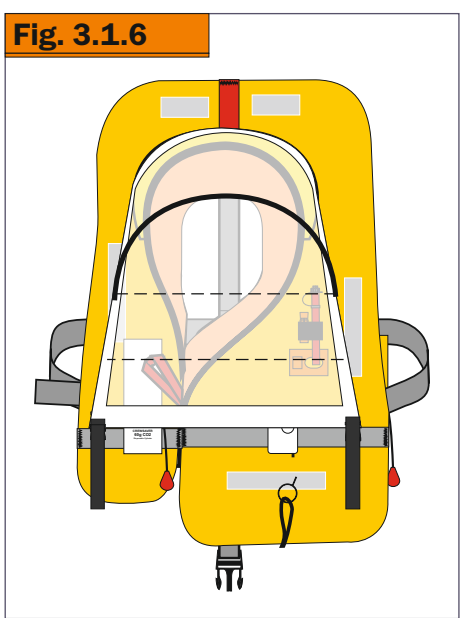
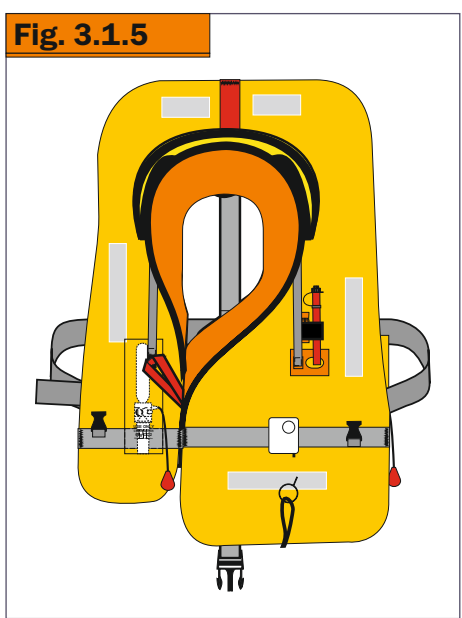
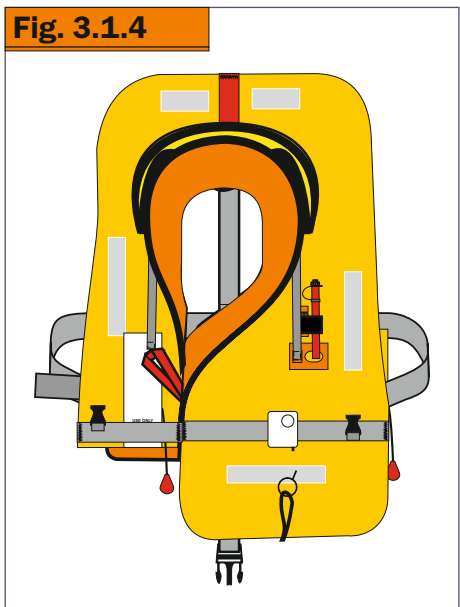
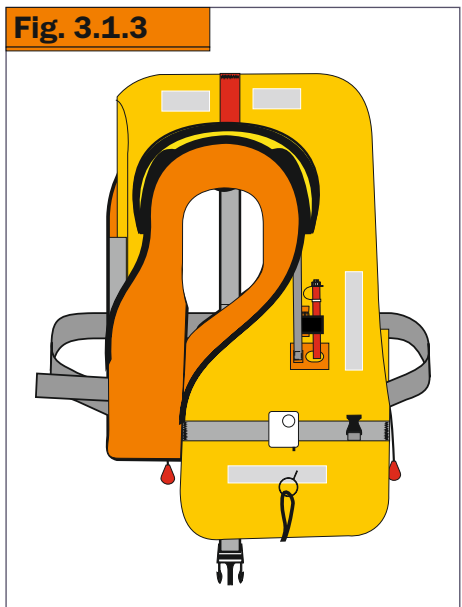
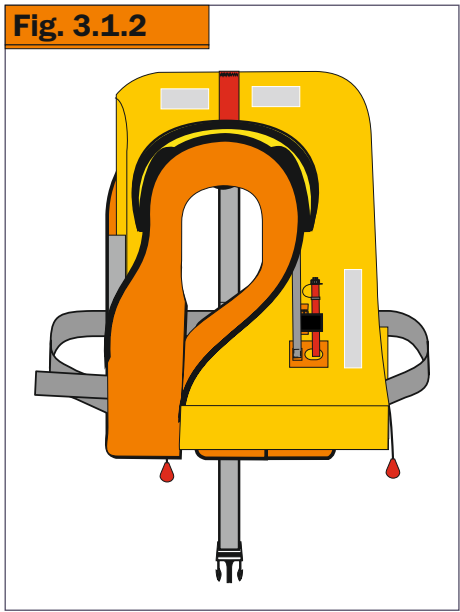
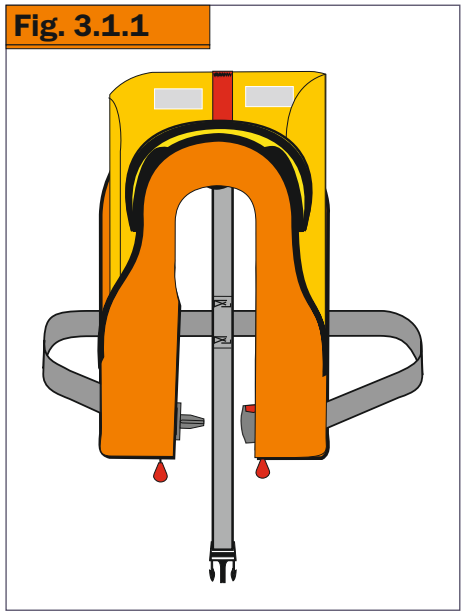
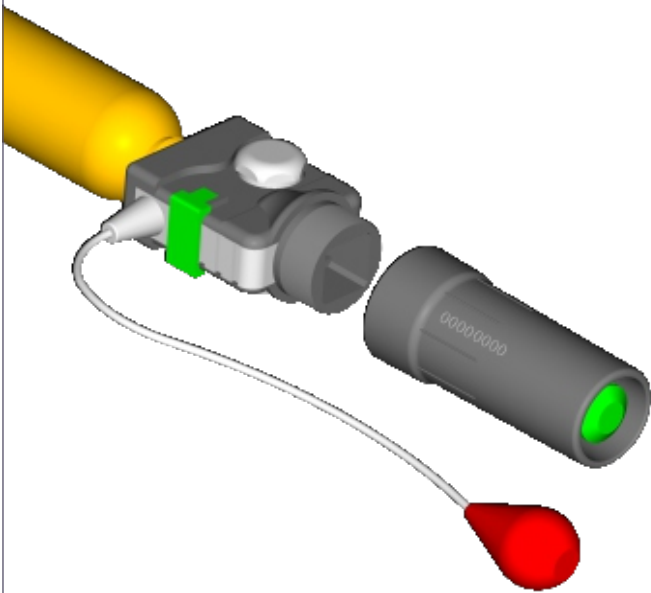

Fig 3.2 United Moulders Operating Head

Fig. 3.2.1



Unscrew the Automatic firing capsule from the end of the operating head. This should only be done after the test detailed in Section 6 has been performed in order to test the old unit, or if the operating head has already been fired. Discard and replace with a new automatic firing capsule upon reassembly. The Capsule must be replaced if it expires before the date of the next annual service.

Fig. 3.2.2

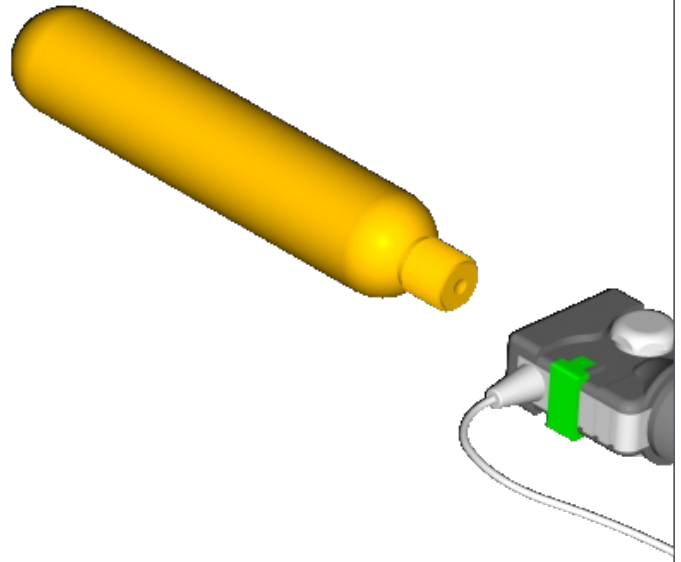

Unscrew the 60 gram cylinder from the automatic operating head. Once the cylinder has been removed inspect the cylinder O-Ring seal. Check the seal is in place and that it is in a good condition. Take the cylinder and check to see if the cylinder has been used. This should be performed by check weighing. If under the minimum weight as displayed on the cylinder body, discard in a safe manner.

Fig. 3.2.3

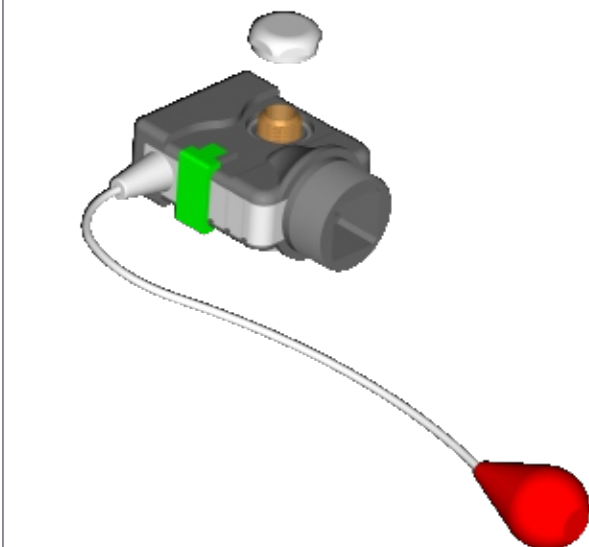

Unscrew the valve retaining nut from the top of the operating head. Check for corrosion and discard if corroded. Inspect the top sealing O-ring. This must be replaced with a new part if damaged.

Fig. 3.2.4

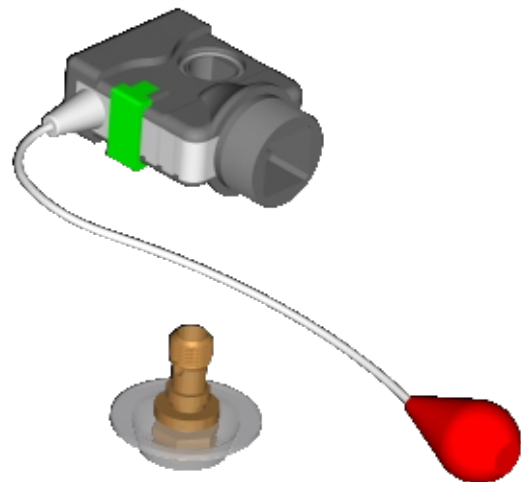

Remove the operating head from the manifold which is welded to the inflation chamber fabric. Inspect the bottom sealing O-ring. This must be replaced with a new part if damaged.

Fig 3.3 United Moulders Mk5 Operating Head

Fig. 3.3.1



Take the new automatic capsule and screw onto the operating head in a clockwise direction. Screw right up ensuring there is no gap between the capsule and operating head and then do up hand tight.

Fig. 3.3.2

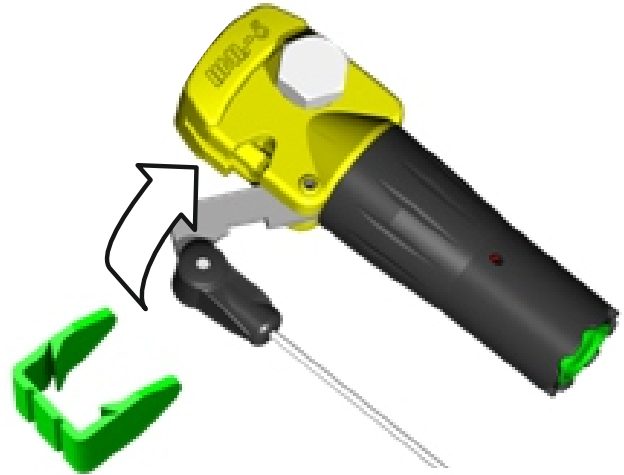

If fired manually replace the operating head arm into the main body and fit the retaining clip. The clip is fitted by pressing it over the firing arm and into the recess either side in the centre of the operating head.

Fig. 3.3.3

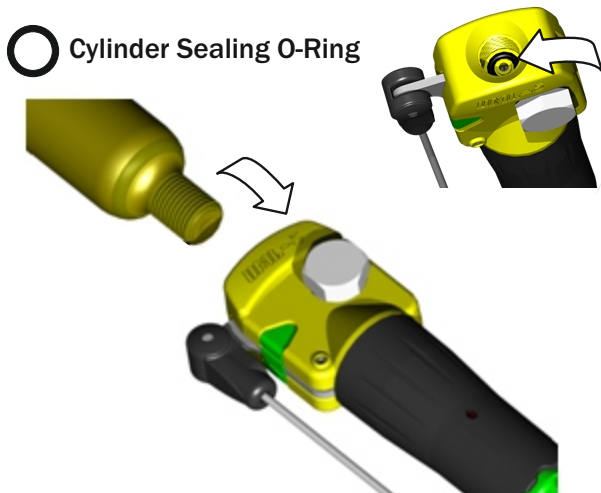

Check that the cylinder sealing gasket in the end of the operating head has been correctly fitted, or replaced if necessary. Check the new CO₂ cylinder has not been used and screw into the main body in a clockwise direction. Ensure the cylinder is screwed right down and do up hand tight.

Fig. 3.3.4



The operating head is now rearmed.

4.1 Cleaning Lifejackets

- 4.1.1 The standard cover of the Seacrewsader has a Polyester fabric outer cover that can be cleaned with care. In the event that contamination is such that the materials are inherently damaged refer to section 7. The Seacrewsader also comes with a Fire Resistant cover or a Heavy Duty cover.
- 4.1.2 For all types of cover, mud can be removed with clean water and the zip can be cleaned with a stiff (not wire) brush when dry.
 - 4.1.2.1 Contaminants such as oil or diesel fuel may be sponged off immediately with clean water, allow to dry naturally.
 - 4.1.2.2 Mud can be removed with a stiff (not wire) brush when dry.
 - 4.1.2.3 Pouches may be hand washed in good quality mild detergent in cool water (40 °C) rinse well, air drip dry.
- 4.1.3 Sponge the inflatable chamber with PURE SOAP SOLUTION ONLY. Rinse in clean water immediately, inflate and air dry.

WARNING: Do not use proprietary cleaning fluids, thinners, spirits or similar substances.

5.1 Cover Inspection

- 5.1.1 Visually inspect the cover material for wear, abrasion, pulled threads, contamination, cuts and holes.
 - 5.1.2 If necessary the cover may be washed. Refer to Section 4.
 - 5.1.3 Effect repairs if necessary and re-inspect for quality of repaired cover. Refer to Section 7.
 - 5.1.4 Carefully examine the zips and the slider for wear, broken teeth or slider and worn or fraying tape.
 - 5.1.5 If it is considered that the cover is beyond economic repair the customer shall be advised and offered a replacement lifejacket.
- NOTE: Due to the construction of this lifejacket no individual cover is available for replacement, therefore the lifejacket as a whole must be replaced.

5.2 Inflatable Chamber Inspection

- 5.2.1 Visually inspect the chamber material for wear, pulled threads, contamination or signs of mistreatment .
- 5.2.2 Visually inspect all welds.
- 5.2.3 Visually inspect all webbings in accordance with Section 5.7
- 5.2.4 Visually inspect the whistle and its attachment to the lifejacket for mistreatment, defects, and fraying of the cord and its attachment.
- 5.2.5 Test Lifejacket in accordance with Section 6.

5.3 Disposable Cylinders

- 5.3.1 Visually examine:
 - 5.3.1.1. For Corrosion (All cylinders corroded with red rust or with visible pitting must be replaced).
 - 5.3.1.2. Pierced or damaged piercing disc.
 - 5.3.1.3. That the two cylinders have the correct gas charge - 60 grams CO₂
- 5.3.2 Check Min Weight of Cylinder against that marked on the barrel.

Fig. 5.3

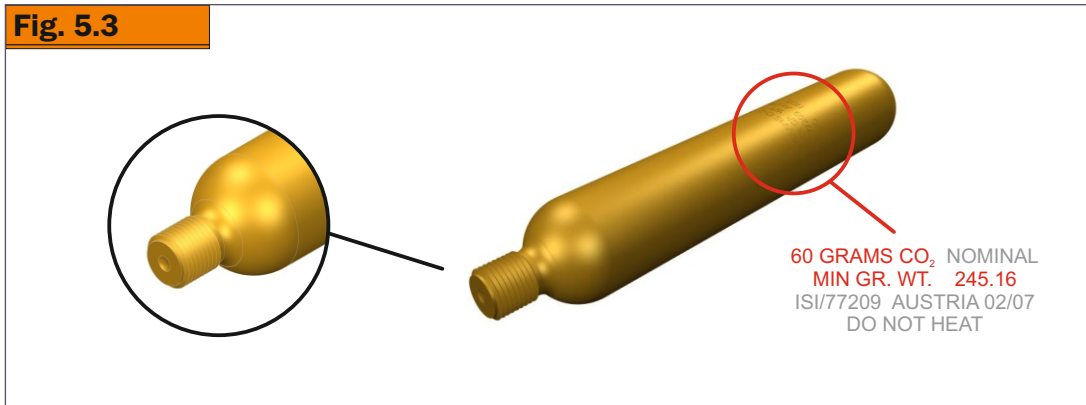

Remedial Action: If any of the above conditions are found to be incorrect the cylinder shall be replaced. See Section 9.

5.4 Light and Battery

- 5.4.1 Visually inspect the L6 light for signs of damage to:
 - 5.4.1.1. the trip line; ensure that the toggle is securely attached.
 - 5.4.1.2. the cable.
 - 5.4.1.3. the lens and its mounting or housing.
- 5.4.2 Check expiry date on battery. The expiry date must exceed the date of the next annual service, if the light has expired or expires before the next service then it must be replaced with a CSL Light. (See Section 9).
- 5.4.3 Test the assembly as detailed in Section 6

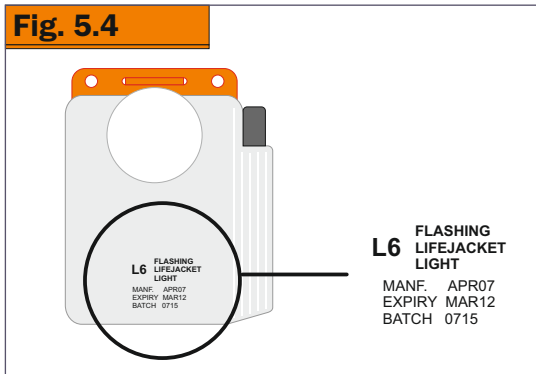

Remedial Action: These items are not repairable refer to Section 9 for replacement Part.

- 5.4.4 More recent jackets may be fitted with the Crewsaver CSL Water Activated Light.
 - Visually inspect the light for signs of damage to:
 - 5.4.4.1. The switch.
 - 5.4.4.2. the cable.
 - 5.4.4.3. the lens and its mounting or housing.
 - 5.4.5 Check expiry date on battery. The expiry date must exceed the date of the next annual service. If the light has expired or expires before the next service then it must be replaced. (See Section 9).

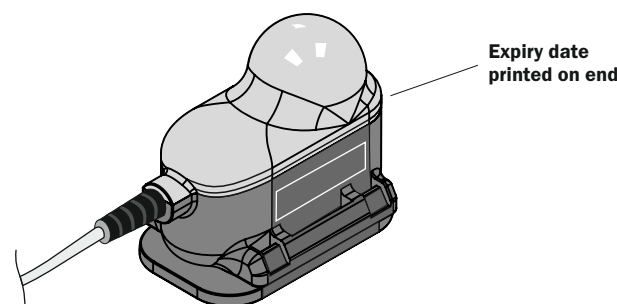

- 5.4.6 Ensure that the switch is in the Auto-on position.

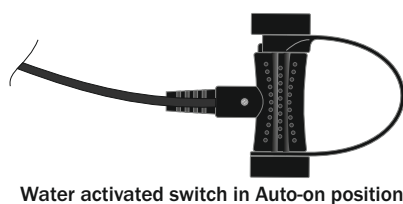

- 5.4.7 Test the assembly as detailed in Section 6

5.5 Oral & Relief Valves

- 5.5.1 Visually inspect for damage.
- 5.5.2 Test in accordance with Section 6.

Remedial Action: These items are not repairable refer to Section 9 for replacement Part.

5.6 Operating Mechanism

- 5.6.1 Visually inspect the Operation of the Mechanism for:
 - 5.6.1.1 Operation of the Manual override lever. This shall move easily and freely.
 - 5.6.1.2 Operation of the firing pin cam action. Similarly this shall be a smooth action when the lever is operated.
 - 5.6.1.3 Firing Pin centre discharge hole clear.
 - 5.6.1.4 Pull cord for frays and damage.
 - 5.6.1.5 Moulded body for cracks and damage. Special attention to be given to the areas around the operating lever/body connection pin.
 - 5.6.1.6 Check the Automatic plunger.

Remedial Action: In the event that the Operating Mechanism fails any of the above inspection procedures, the complete unit shall be replaced. No Repairs are allowed. Refer to Section 9 for the part number of the relevant replacement part.

- 5.6.2 Visually inspect the Automatic Capsule:
 - 5.6.2.1 Check plug is in place at the base of the capsule.
 - 5.6.2.2 No Capsules are to be fitted where the expiry date does not exceed the next annual service of the lifejacket.
 - 5.6.2.2.1 If the capsule is to be replaced – Re-fit the old capsule and carry out operational tests refer to section 6.

Remedial Action: In the event that the Operating Mechanism fails any of the above inspection procedures, the complete Unit shall be replaced. No repairs are allowed. Refer to Section 9 for the part number of replacement parts.

5.7 Webbings

- 5.7.1 Visually inspect for damage:
 - 5.7.1.1 Fraying
 - 5.7.1.2 Pulled Threads
 - 5.7.1.3 Broken Stitches

Remedial Action: Effect repairs in accordance with the Repair Procedures within the limits defined in Section 7.

5.8 Buckles

- 5.8.1 Visually inspect all buckles used on the webbings for signs of damage or corrosion.

Remedial Action: No repairs are allowed. In the case of damage being found replace the complete Pouch and Webbing assembly. Refer to Section 9 for the part number of the relevant replacement part.

5.9 Spray Hood

- 5.9.1 Visually inspect the spray hood for:
 - 5.9.1.1. Damage to the points of attachment to the Lifejacket.
 - 5.9.1.2. Cracking or crazing of the clear plastic face shield.
 - 5.9.1.3. Damage or degradation of the velcro.
 - 5.9.1.4. Fraying of Material.
 - 5.9.1.5. Check stiffening tube of hood.

5.10 Labelling/Markings

5.10.1. Check all Markings and Labelling are clear and legible.

Remedial Action: If the markings or labelling have seriously deteriorated then the lifejacket must be replaced.

5.11 Hermetically Sealed Products

- 5.11.1 Visually inspect:
- 5.11.1.1. the integrity of the bag and check it has not been damaged.
 - 5.11.1.2. the tear point for evidence of tampering.
 - 5.11.1.3. the welded seal for wear and tear or holes.

Remedial Action: If the bag is damaged and fails the above inspections then the bag must be replaced and the Lifejacket must be serviced.

- 5.11.1.2. Labelling and Printing.
- 5.11.1.2.1. Check that the visible labelling and printing is legible.

NOTE: Capsules are marked with a three year expiry life. When lifejackets are packed into a hermetically sealed bag - that life should be extended to 5 years. Bags must be marked in the space provided - with capsule dates of expiry extended by two years. (Therefore a product marked with replace by: 10 2010 should be written as replace by 10 2012)

Remedial Action: If the labelling on the bag is damaged this may be replaced. Refer to Section 9 for the part number.

- 5.11.1.2.2. The labelling should be checked to ensure the expiry dates of the components are visible and have not expired and will not expire before the next annual service.

Remedial Action: If any Components have expiry dates exceeding the date marked on the bag or the date shown on the product then the Lifejacket must be serviced.

If the Lifejacket passes the above inspection procedures please fill in the I

5.11 Hermetically Sealed Products

- 5.11.2 For servicing larger batches of lifejackets the following actions must be taken:
 - 5.11.2.1. 100% visual inspection is required every 6 Months.
 - See Section 5.11.1. for inspection procedures or see the Bag label 5.11.3.
 - 5.11.2.2. 20% of each batch must be serviced every year.
 - 5.11.2.2.1. All Automatic Firing Capsules removed from the 20% of serviced jackets must be tested by plunging the operating head into water. In the event of a failure, Crewsaver must be notified immediately and details of the Capsule provided (Serial and Batch numbers).

Remedial Action: Should any one jacket from the 20% fail, the whole batch must be serviced and the Hermetically sealed bag must be replaced. Ensure that every new bag has a label present and is filled out with the correct information for the lifejacket included.

5.11.3 Hermetically Sealed Bag Label:

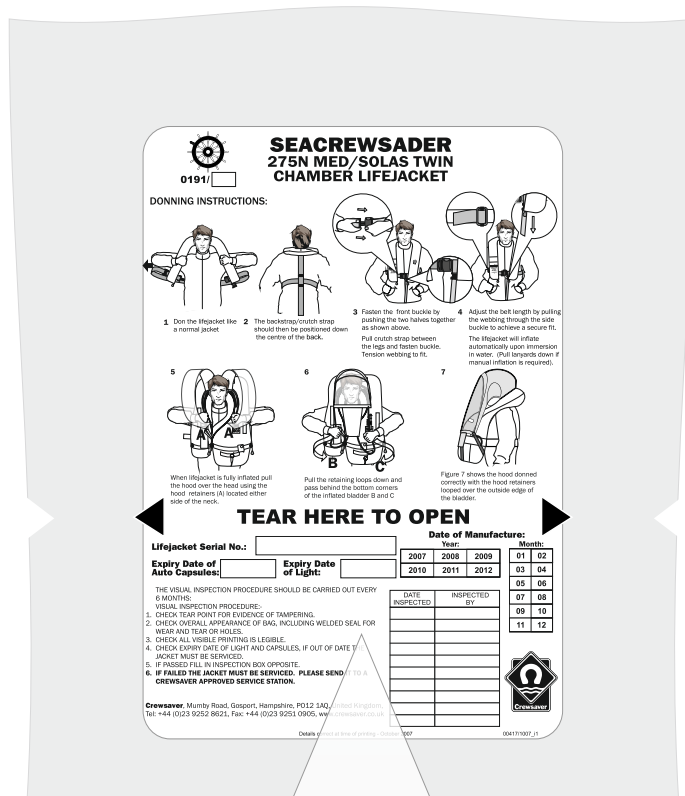

Lifejacket Serial No.:

Expiry Date of Auto Capsules: **Expiry Date of Light:**

Date of Manufacture:

2007	2008	2009	01	02
2010	2011	2012	03	04
			05	06
			07	08
			09	10
			11	12

THE VISUAL INSPECTION PROCEDURE SHOULD BE CARRIED OUT EVERY 6 MONTHS:

VISUAL INSPECTION PROCEDURE:-

- CHECK TEAR POINT FOR EVIDENCE OF TAMPERING.
- CHECK OVERALL APPEARANCE OF BAG, INCLUDING WELDED SEAL FOR WEAR AND TEAR OR HOLES.
- CHECK ALL VISIBLE PRINTING IS LEGIBLE.
- CHECK EXPIRY DATE OF LIGHT AND CAPSULES, IF OUT OF DATE THE JACKET MUST BE SERVICED.
- IF PASSED FILL IN INSPECTION BOX OPPOSITE.
- IF FAILED THE JACKET MUST BE SERVICED. PLEASE SEND IT TO A CREWSAVER APPROVED SERVICE STATION.**

Crewsaver, Mumby Road, Gosport, Hampshire, PO12 1AQ, United Kingdom, Tel: +44 (0)23 9252 8621, Fax: +44 (0)23 9251 0905, www.crewsaver.co.uk

DATE INSPECTED	INSPECTED BY



6.1 Inflatable Chamber

6.1.1. Air Holding Test. (Both Chambers must be tested independently)

6.1.1.1 Connect through a suitable Tee piece and adaptor, the oral tube with the oral valve in the open position, to a graduated water manometer (or a similar digital device for measuring back pressure).

6.1.1.2 Slowly inflate the lifejacket from a regulated supply until the relief valve expels excess.

Warning: Regulated supply pressure must not exceed 20psi.

6.1.1.3 Close off the air supply and leave for 10 minutes to ensure pressure is stable.

6.1.1.4 Check and record the pressure and temperature reading on the Service Record Sheet.

6.1.1.5 Leave for 30 minutes.

6.1.1.6 Check and record the pressure and temperature reading on the Service Record Sheet.

The maximum difference in the two pressure readings (pressure drop) allowed is 10%. The temperature differential shall be within plus or minus 3 degrees of the original reading. For each degree Centigrade rise in temperature subtract 2.5 mbar. For each degree Centigrade drop in temperature add 2.5 mbar to the readings to obtain the actual pressure variation. Should the temperature variation be outside 3 degrees either way then the test shall be repeated.

PSI	in/H ₂ O	in/Hg	mm/H ₂ O	mm/Hg	kg/cm ²	bar	mbar	Pa	kPa
1.0	27.71	2.036	703.1	51.75	0.0703	0.0689	68.95	6895	6.895
1.1	30.48	2.240	773.4	56.93	0.0773	0.0758	75.85	7585	7.585
1.2	33.25	2.443	843.7	62.10	0.0844	0.0827	82.74	8274	8.274
1.3	36.02	2.647	914.0	67.28	0.0914	0.0896	89.64	8964	8.964
1.4	38.79	2.850	984.3	72.45	0.0984	0.0965	96.53	9653	9.653
1.5	41.57	3.054	1054.7	77.63	0.1055	0.1034	103.43	10343	10.34
1.6	44.34	3.258	1125.0	82.80	0.1125	0.1102	110.32	11032	11.03
1.7	47.11	3.461	1195.3	87.98	0.1195	0.1171	117.22	11722	11.72
1.8	49.88	3.665	1265.6	93.15	0.1265	0.1240	124.11	12411	12.41
1.9	52.65	3.868	1335.9	98.33	0.1336	0.1309	131.01	13101	13.10
2.0	55.42	4.072	1406.2	103.50	0.1406	0.1378	137.90	13790	13.79
2.1	58.19	4.276	1476.5	108.68	0.1476	0.1447	144.80	14480	14.48
2.2	60.96	4.479	1546.8	113.85	0.1547	0.1516	151.69	15169	15.17
2.3	63.73	4.683	1617.1	119.03	0.1617	0.1585	158.59	15859	15.86
2.4	66.50	4.886	1687.4	124.20	0.1687	0.1654	165.48	16548	16.55
2.5	69.28	5.090	1757.8	129.38	0.1758	0.1723	172.38	17238	17.24
2.6	72.05	5.294	1828.1	134.55	0.1828	0.1791	179.27	17927	17.93
2.7	74.82	5.497	1898.4	139.73	0.1898	0.1860	186.17	18617	18.62
2.8	77.59	5.701	1968.7	144.90	0.1968	0.1929	193.06	19306	19.31
2.9	80.36	5.904	2039.0	150.08	0.2039	0.1998	199.96	19996	20.00
3.0	83.13	6.108	2109.3	155.25	0.2109	0.2067	206.85	20685	20.69
3.1	85.90	6.312	2179.6	160.43	0.2179	0.2136	213.75	21375	21.37
3.2	88.67	6.515	2249.9	165.60	0.2250	0.2205	220.64	22064	22.06
3.3	91.44	6.719	2320.2	170.78	0.2320	0.2274	227.54	22754	22.75
3.4	94.21	6.922	2390.5	175.95	0.2390	0.2343	234.43	23443	23.44
3.5	96.99	7.126	2460.9	181.13	0.2461	0.2412	241.33	24133	24.13
3.6	99.76	7.330	2531.2	186.30	0.2531	0.2480	248.22	24822	24.82
3.7	102.53	7.533	2601.5	191.48	0.2601	0.2549	255.12	25512	25.51
3.8	105.30	7.737	2671.8	196.65	0.2671	0.2618	262.01	26201	26.20
3.9	108.07	7.940	2742.1	201.83	0.2742	0.2687	268.91	26891	26.89
4.0	110.84	8.144	2812.4	207.00	0.2812	0.2756	275.80	27580	27.58
4.1	113.61	8.348	2882.7	212.18	0.2882	0.2825	282.70	28270	28.27
4.2	116.38	8.551	2953.0	217.35	0.2953	0.2894	289.59	28959	28.96
4.3	119.15	8.755	3023.3	222.53	0.3023	0.2963	296.49	29649	29.65
4.4	121.92	8.958	3093.6	227.70	0.3093	0.3032	303.38	30338	30.34
4.5	124.70	9.162	3164.0	232.88	0.3164	0.3101	310.28	31028	31.03
4.6	127.47	9.366	3234.3	238.05	0.3234	0.3169	317.17	31717	31.72
4.7	130.24	9.569	3304.6	243.23	0.3304	0.3238	324.07	32407	32.41
4.8	133.01	9.773	3374.9	248.40	0.3374	0.3307	330.96	33096	33.10
4.9	135.78	9.976	3445.2	253.58	0.3445	0.3376	337.86	33786	33.79
5.0	138.55	10.180	3515.5	258.75	0.3515	0.3445	344.75	34475	34.48
5.1	141.32	10.384	3585.8	263.93	0.3585	0.3514	351.65	35165	35.16
5.2	144.09	10.587	3656.1	269.10	0.3656	0.3583	358.54	35854	35.85
5.3	146.86	10.791	3726.4	274.28	0.3726	0.3652	365.44	36544	36.54
5.4	149.63	10.994	3796.7	279.45	0.3796	0.3721	372.33	37233	37.23
5.5	152.41	11.198	3867.1	284.63	0.3867	0.3790	379.23	37923	37.92
5.6	155.18	11.402	3937.4	289.80	0.3937	0.3858	386.12	38612	38.61
5.7	157.95	11.605	4007.7	294.98	0.4007	0.3927	393.02	39302	39.30
5.8	160.72	11.809	4078.0	300.15	0.4077	0.3996	399.91	39991	39.99
5.9	163.49	12.012	4148.3	305.33	0.4148	0.4065	406.81	40681	40.68
6.0	166.26	12.216	4218.6	310.50	0.4218	0.4134	413.70	41370	41.37

6.1.1.7. If Lifejacket fails the Air holding test inspect as follows.

6.1.1.7.1 With the lifejacket inflated carefully brush the surface with a weak solution of soap and water or alternatively lower the lifejacket into a tank of water to observe for bubbles.

6.1.1.7.2 Identify and mark the source of leakage. Wash off in clean water and allow to dry naturally in air.

6.1.1.7.2.1 Special Attention to be given to:

- a) Manifold Schraeder Core
- b) Oral Tube/ Top-up Valve
- c) Oral Tube/ Relief Valve

- 6.1.2 Subsequent to the air holding test in para 6.1 slowly inflate the lifejacket until the relief valve vents (Opens). Record the pressure reading on the manometer.
 - 6.1.2.1. Allow the pressure to relieve through the valve until the relief valve reseats (Closes). Record the pressure reading. Note: Relief valves should operate at 1.5psi. Relief valves that do not operate within the 1.5 - 2.0 psi range must be replaced.
 - 6.1.2.2. The Opening (vent) and closing (reseat) readings shall be within 15% of the original reading. Note: Valves that fail to reseat within the 15% tolerance must be replaced.
- 6.1.3 If the test is satisfactory deflate the Lifejacket in preparation for re-assembly. Refer to Section 8.
 - 6.1.3.1. Insert the inverted oral valve dust cap into the top of the oral valve and expel the air.
- 6.1.4 Effect repairs in accordance with the Repair Procedures within the limits defined in Section 7.
- 6.1.5 Subsequent to remedial action being taken (see Section 7), retest the lifejacket in accordance with Section 6.

6.2 Valves

- 6.2.1. Oral Valves.
 - 6.2.1.1. When removing the test adapter from each oral valve check that the oral valve reseats. If in doubt this may be checked by placing the valve underwater.
- 6.2.2. Relief Valves.
 - 6.2.2.1. Relief Valves should be tested as detailed in 6.1.1.7, if defective the relief valve must be changed Refer to Section 9 for replacement part.
- 6.2.3 Schraeder Valves.
 - 6.2.3.1 Should a leak be found in the Schraeder valve the faulty core must be removed and a new valve inserted using the Torque Screwdriver from the tool kit.

6.3 Operating Mechanisms

- 6.3.1 Operational Test for United Moulders Manual Operation.
 - 6.3.1.1 Remove the operating mechanism from the lifejacket. With the cylinder also removed, pull the lever on the side of the operating head, and check that the firing pin is visibly moving inside the open end.
 - 6.3.1.2 If the lever does not move, or the firing pin is not clearly moving, the operating head must be replaced. Refer to Section 9 for part number.
- 6.3.2 Operational Test for United Moulders Automatic Operating Heads (to be performed when capsules have expired).
 - 6.3.2.1 Remove the operating mechanism from the lifejacket and remove the cylinder.
 - 6.3.2.2 Assemble the expired capsule onto the body of the operating mechanism.
 - 6.3.2.3 Place the complete unit into water and check that the unit operates within 5 seconds.
 - 6.3.2.4 If the mechanism fails to pass this test replace the complete unit. Refer to Section 9 for part Number of the replacement part.
NOTE: all failures of this test must be reported to Crewsaver. Crewsaver may require the failed units to be returned. Please do not discard.

6.4 Lights and Batteries

- 6.4.1. McMurdo L6
The McMurdo L6 can be tested using the switch located on the right side (as looked at).

WARNING. If the light has expired regardless of its functionality it must be discarded and replaced with a CSL Light.

6.4.2 Crewsaver CSL Water Activated Light.

Visually inspect the light for signs of damage to:

6.4.2.1 the switch.

6.4.2.2 the cable.

6.4.2.1 the lens and its mounting or housing.

6.4.3 Check expiry date on battery. The expiry date must exceed the date of the next annual service. If the light has expired or expires before the next service then it must be replaced. (See Section 9).

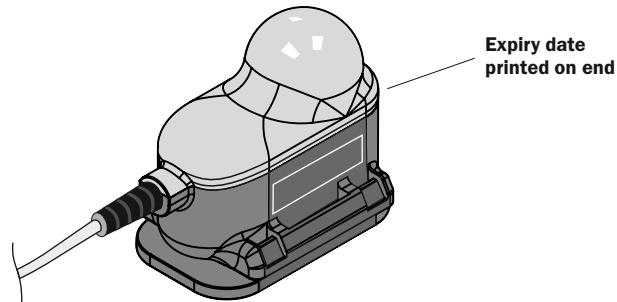

6.4.4 Ensure that the switch is in the Auto-on position.

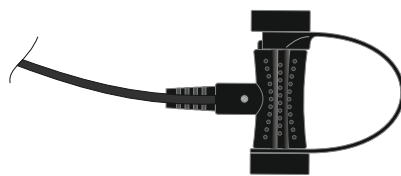

Water activated switch in Auto-on position

6.4.5 Test the assembly as detailed in Section 6

6.5 Retro Reflective Tape

- 6.5.1 If the retro reflective tape shows any signs of degradation the following tests shall be carried out in accordance with Marine Guidance Note MGN 105 (M+F) Issued by the UK Marine and Coast guard Agency March 1999, the retro-reflective material shall be tested at each service as follows.
- 6.5.1.1 Place a new piece of the same retro-reflective material to, and on the same plane as, a representative piece of material fitted to the appliance.
 - 6.5.1.2 Pour water over both pieces of material.
 - 6.5.1.3 Using a powerful torch or "Aldis" lamp held at eye level, compare the performance of the two pieces of material from a distance of 10 Metres.
 - 6.5.1.4 If a noticeable deterioration in performance is observed then the retro-reflective material on the appliance should be replaced.
 - 6.5.1.5 Dry off the lifejacket before repacking.

6.6 Hermetically Sealed Bags

6.6.1 To test the bag for leaks gently apply pressure to the outside of the bag. If air is escaping from the bag when pressure is applied the bag has a leak and the lifejacket will need to be removed and placed into a new bag.

7.1 Cover

7.1.1 Attaching a patch on to the inside of the pouch using a compatible adhesive may be used to repair cuts and holes in the pouch. Cuts which may be repaired in this manner are limited to:

- 7.1.1.1 No more than 25mm in length in any direction.
- 7.1.1.2 Patches must not be within 25mm of any stitching, fixing points or markings.
- 7.1.1.3 The cut is covered by a minimum of 25mm of patch. See Fig 7.1
- 7.1.1.4 The patch does not interfere with the operation and egress of the lifejacket stole.

7.1.2 For Stitching Repairs refer to Fig 7.2

7.1.3 No other repairs are allowed on the pouch.

7.2 Inflatable Chamber

7.2.1 No repairs are permitted to the chambers fabric or its assembly, due to the construction of this lifejacket.

7.2.2 Components attached to the chambers may be repaired in line with the limits defined below.

7.3 Disposable Cylinders

7.3.1 No repairs permitted. For the Part No. of the replacement part refer to Section 9

7.3.2 Please ensure cylinders are disposed of in accordance with local regulations.
Treat empty cylinders as steel for recycling purposes.

7.4 Light and Battery

7.4.1 No repairs permitted. For the Part No. of the replacement part refer to Section 9

7.5 Oral & Relief Valves

7.5.1 No repairs permitted. For the Part No. of the replacement parts refer to Section 9

7.5.2 Replacement of the Oral or Relief valve may be achieved by.

7.5.2.1 Carefully removing the defective unit by applying force, with a blunt instrument, behind the oral valve
Squeezing the tube and gently pushing the valve out.

7.5.2.2 Push the replacement valve into the oral tube.

Fig. 7.5

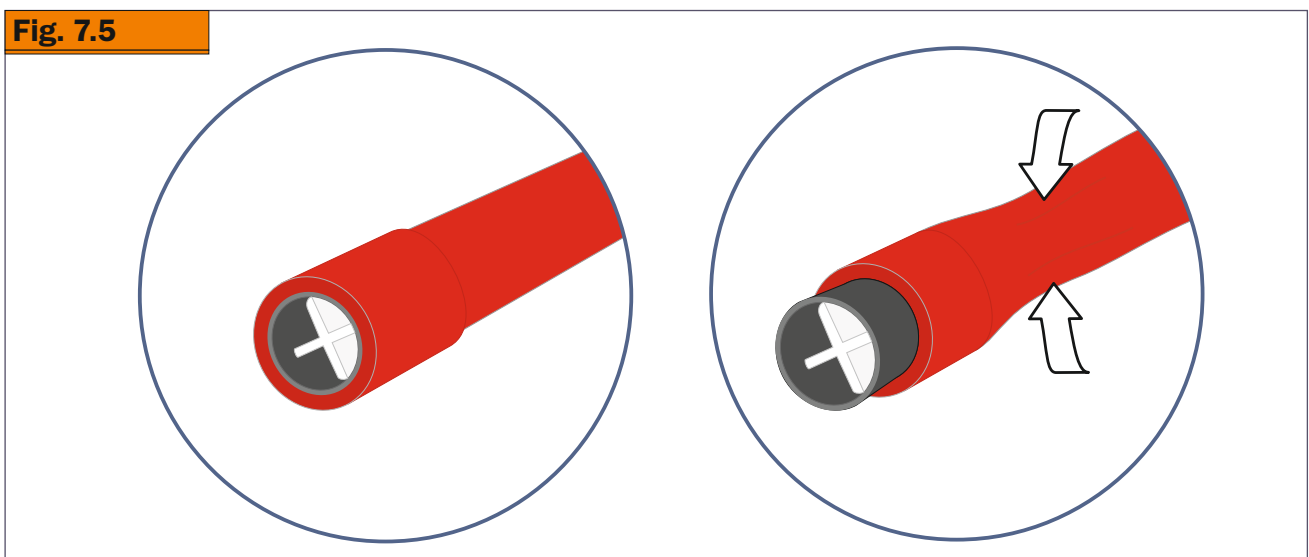

7.6 Operating Mechanism System

7.6.1 A Schraeder core is located inside the Valve Stem.

7.6.1.1 Remove and replace using the calibrated torque driver for Schraeder valves set to 0.32 - 0.36 Nm.
Refer to Section 9 for the Part No. of the replacement part.

WARNING: Only fit replacement Schraeder valves obtained from Crewsaver.

7.6.2 Operating Mechanism.

7.6.2.1 No repairs permissible. Replace the complete unit.
Refer to Section 9 for the Part No. of the replacement part.

7.7 Webbings

7.7.1 No cuts are allowed in the webbing of any of these components. No repairs are permitted on the webbing of Harness Lifejackets. Worn, broken or cracked stitches are to be over sewn by 25mm in each direction past the extent of the fault, use only approved thread. (Refer to Crewsaver) In the Case of the Crotch Strap Replace Damaged Unit. Refer to Section 9 for Part No. of the replacement part.

7.8 Buckles

7.8.1. These components are not repairable or replaceable. Replace the complete Pouch and Webbing Assembly. Refer to Section 9 for the part number of the relevant assembly.

7.9 Spray Hood

7.9.1. No Repairs Permitted. Refer to Section 9 for Part Number of replacement Spray Hood.

7.10 Repair Parameters - Holes in Pouch

- a.) Attaching a patch on to the inside of the pouch, using a compatible adhesive, may be performed to repair cuts and holes in the pouch. This is the only part of a lifejacket that may be repaired. Cuts and holes that may be repaired in this manner are limited to:
 - ai. No more than 25mm in length in any direction.
 - aii. Cut or Holes not crossing any lines of stitching.
 - aiii. Cuts or Holes no closer than 25mm from any fixing points, or screen-printing / marking.
 - aiv. An example of a repairable hole is shown below

Hole Size does not exceed 25mm

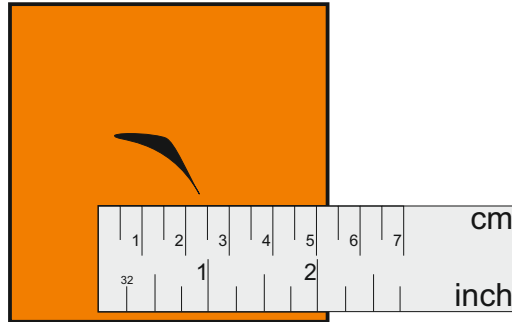

Outer line corresponds to the size of the patch that would be applied to this hole.

- b.) When performing a repair the following considerations must be adhered to:
 - bi. For the correct type of adhesive contact Crewsaver
 - bii. Patches must always be cut from identical material to the pouch or fabric to be repaired
 - biii. There must be a minimum of 25mm excess patch covering the hole in all directions
 - biv. Patches should always be adhered to the outside of the pouch only.
 - bv. Ensure the fabric is both clean and dry before the application of glue.

7.11 Repair Parameters - Stitching

All repairs to stitching must be carried out by a company deemed fit to perform the repair by Crewsaver prior to the work commencing.

- a.) Stitching repairs should be performed when the visible inspection as detailed in section 5, Para 5.7 identifies broken or pulled stitches. The following repairs maybe made:
 - ai. Repairs to broken stitches should be over sewn following the same line of stitching , ensuring that the stitching continues for a minimum of 20mm past the repair section, each end must be back tacked twice.
 - aii. Repairs to pull threads should be repaired by first trimming the lose ends and then repeating the process as detailed above.
 - aiii. Any repairs carried out must be made using the correct thread available from Crewsaver. No other types of thread are to be used.
 - aiv. No stitching repairs are to be made to the stole, or parts stitched to it.
 - av. No stitching repairs are to be made on Harness Lifejackets

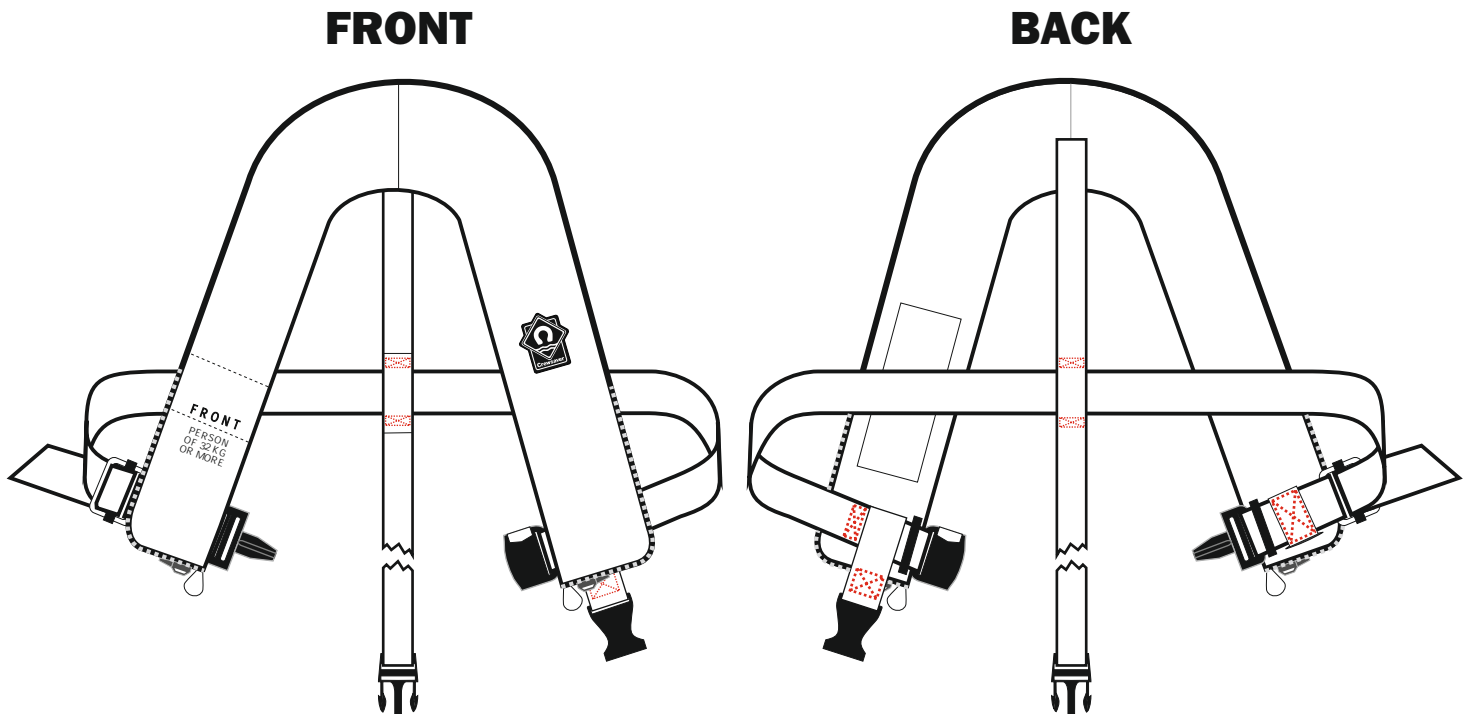

8.1 Assembly

- 8.1.1 Ensure the whistle is positioned and tied in correctly.
- 8.1.2 Expel the air from both chambers by inverting the dust cap on the oral tube. **Do not use vacuum pumps to deflate lifejackets.**
- 8.1.3 Assemble the Operating Mechanism to the inflator.
 - 8.1.3.1 United Moulders Automatic Operating Mechanism Re-arming. See 8.2
 - 8.1.3.1.1 A new retaining clip must be fitted. Refer to Section 9 for replacement parts.
 - 8.1.3.1.2 Fit the gas cylinder to the firing mechanism using the torque wrench (4Nm) and head adaptor from the tool kit. The cylinder is gripped in one hand and the head tightened using the torque wrench held in the other hand.
 - 8.1.3.1.3 Fit the new automatic firing capsule to the operating head, screw hand tight.
 - 8.1.3.1.4 Locate operating head onto the manifold.
 - 8.1.3.1.5 Tighten the retaining nut onto the body using the Calibrated torque driver provided in the Crewsaver servicing tools. Note: Retaining nut must be tightened to between 2.5 and 2.7 Nm.

Warning: Care must be taken not to 'cross thread' the connection.

- 8.1.4 To re-pack the lifejacket. See 8.3.
- 8.1.5 Expel additional excess air, during the packing operation, from within the bladder by again inverting the cap on the oral tube and inserting it into the oral valve. When all excess has been expelled replace the cap.
- 8.1.6 Mark Service Label on Lifejacket (using an indelible pen) and Service Record Sheet with the date of the service.
- 8.1.7 Ensure the serial number has been correctly recorded and that it is clearly marked on the Record Sheet.

Warning: The lifejacket folding procedures must be followed accurately to ensure that the lifejacket inflation mechanism operates and the lifejacket deploys correctly. The lifejacket shall not be folded and/or packed using any other method or procedure than that specified.

8.2 United Moulders Operating Head

Check that the cylinder sealing gasket in the end of the operating head has been correctly fitted, or replaced if necessary. Fit the 60 gram CO₂ cylinder. Ensure that the cylinder has been check weighed before fitting to the lifejacket. Fit the gas cylinder to the firing mechanism using the torque wrench (4Nm) and head adaptor from the tool kit. The cylinder is gripped in one hand and the head tightened using the torque wrench held in the other hand.

Fig. 8.2.1

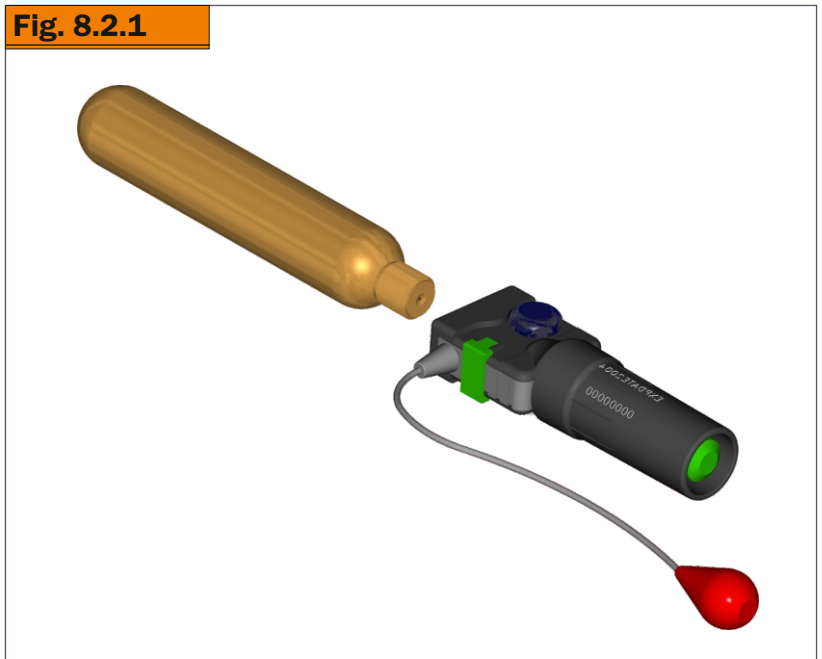
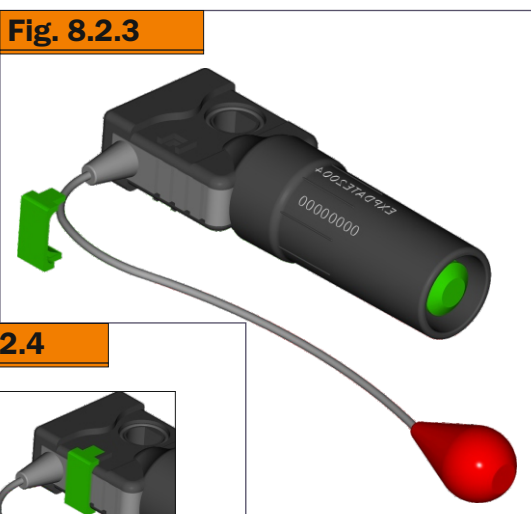

Fig. 8.2.2



Fit the new firing capsule onto the operating head. The capsule should be screwed tight to the end. Make a note of the batch number and manufacture date on to the service record sheet.

Fig. 8.2.3



With the firing capsule fitted, fit the retaining clip. The clip is fitted by pressing it over the firing arm and in to the recess either side in the centre of the operating head. The clip will click into place, thereby preventing the arm from moving.

Fig. 8.2.4

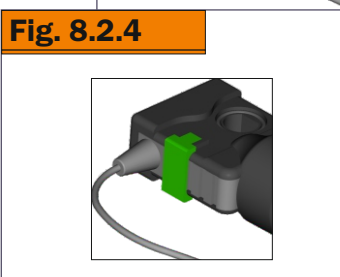

8.2 United Moulders Operating Head

Fig. 8.2.5

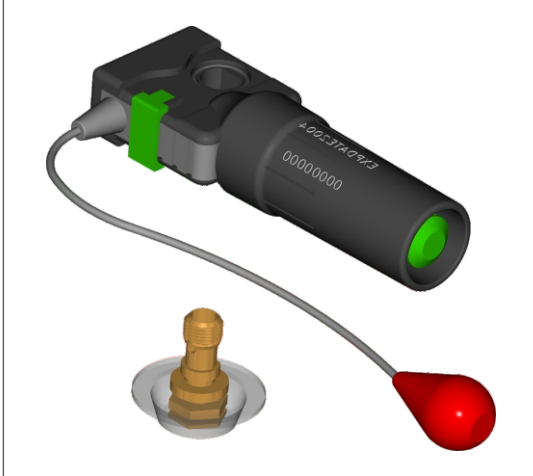

Check the bottom O-ring seal is in place. Before fitting the operating head onto the manifold, check that the schraeder valve is fitted. If fitting a new schraeder valve use a calibrated torque driver set to 0.32 - 0.36 Nm. Then place the operating head onto the manifold , so that the cylinder is pointing upwards.

Fig. 8.2.6

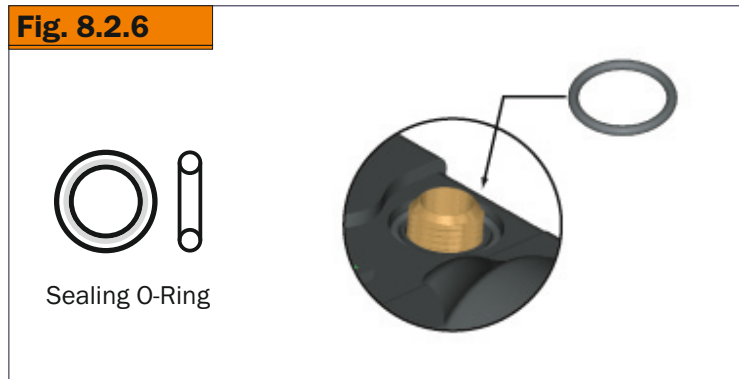
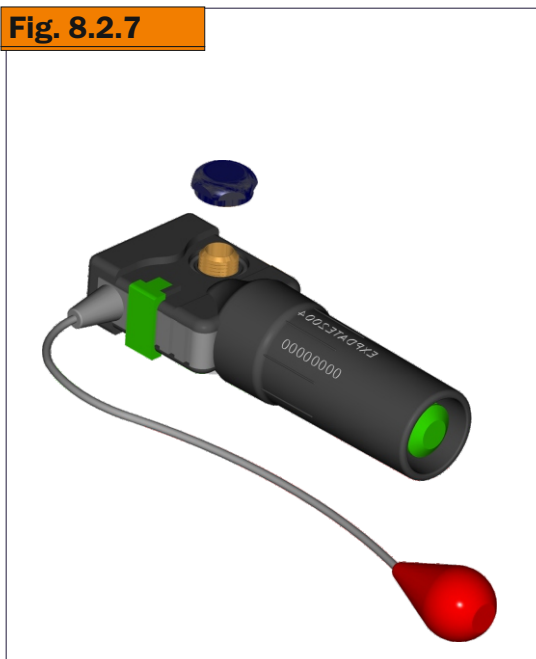

Fig. 8.2.7



Check the O-ring seal is in the recess on the top face of the operating head. With the top O-ring in place, fit the retaining nut. The retaining nut should be screwed into place using a torque wrench or driver fitted with a 9/16" socket. The wrench or driver should be set to between 2.5 and 2.7 Nm. This will prevent damage to the operating head and ensure a good seal is maintained.

8.3 Seacrewsader Packing Instructions

8.3.1 Prior to packing please ensure you have read and understood the requirements of Service bulletin No 26 & No 27. (See back of manual)

All operating head covers must have been removed - all plastic moulded pull cords replaced using the free issue kit provided by Crewsaver. Plastic mesh cylinder covers must be fitted.

Note: The packing method of this lifejacket is very important - if you have any doubt packing please contact Crewsaver.

1

Following inspection of the lifejacket. Lay the deflated jacket out on a flat dry surface. Ensure dust caps are fitted. Concertina fold the sprayhood using approximately 80mm folds.

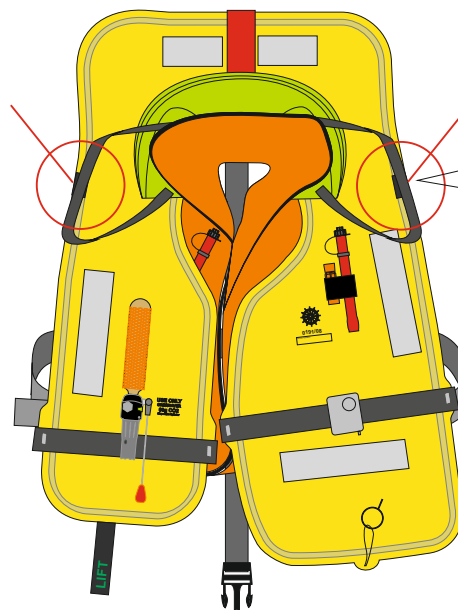

Ensure that the spray hood donning loops are attached to the velcro tabs either side of the inflation chamber.

2

Starting with the rightside of the lifejacket as worn, fold along the line formed by central seam of the cover. The fold should allow for the oral/relief tube to be visible. Pull the fold of inflation chamber over complete with operating head and cylinder to ensure that operating head is positioned centrally in the lower half of the back cover.



The edge of the chamber should fall underneath the operating head pin and cylinder. Note: The webbing retainer sewn to the edge of the inflation chamber should be positioned underneath the operating head capsule as shown.

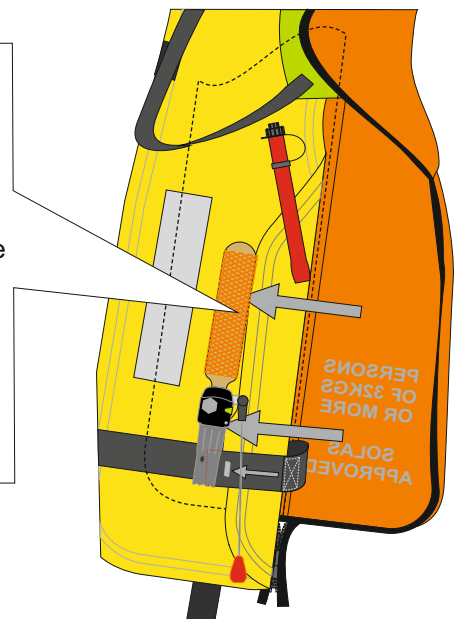

8.3 Seacrewsader Packing Instructions

3

Fold up the bottom edge, the fold should be inside the bottom zipped edge of the cover. Fold back and position underneath the operating head capsule. The fold must be over the top of the webbing retainer.



4

Fold over the outside edge of the inflation chamber. The fold must be made just inside the edge of the cover - running top to bottom. Position the fold over the top of the operating head.

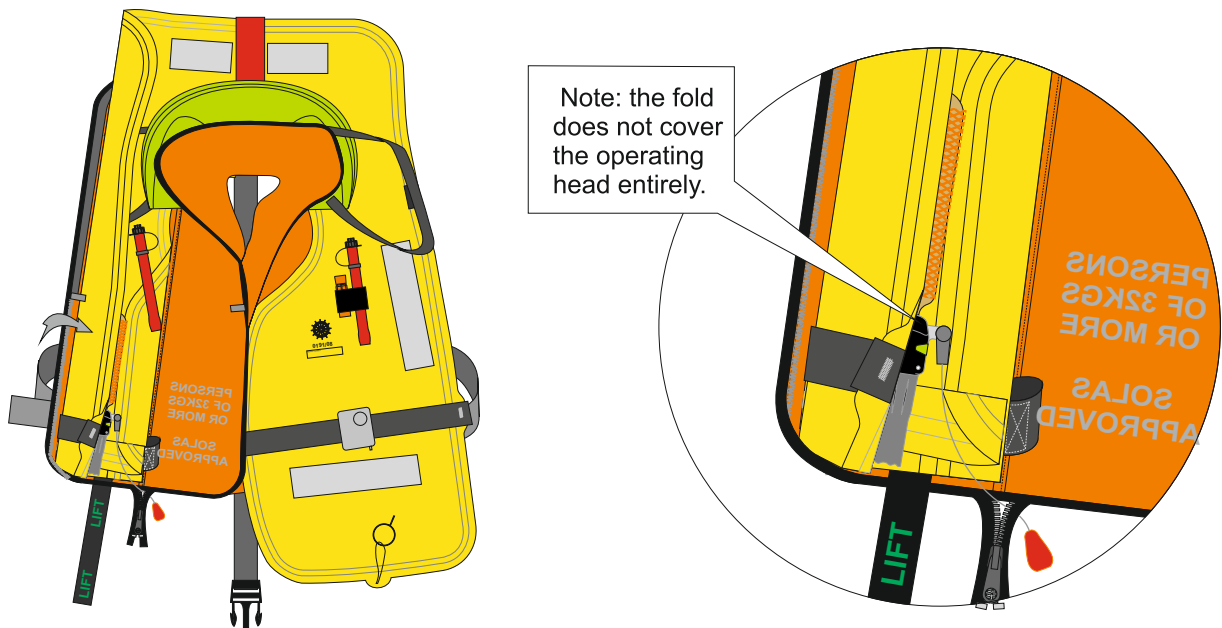

8.3 Seacrewsader Packing Instructions

5 Fold up the lifting becket - and lay on top of the operating head covering the firing arm. Ensure that the becket does not loop over the cylinder.



6 Fold cover over and close the velcro tabs at the top of the zip. Ensuring that the firing cord and toggle is positioned through the zip, run zip slider to top of zip and back to close.

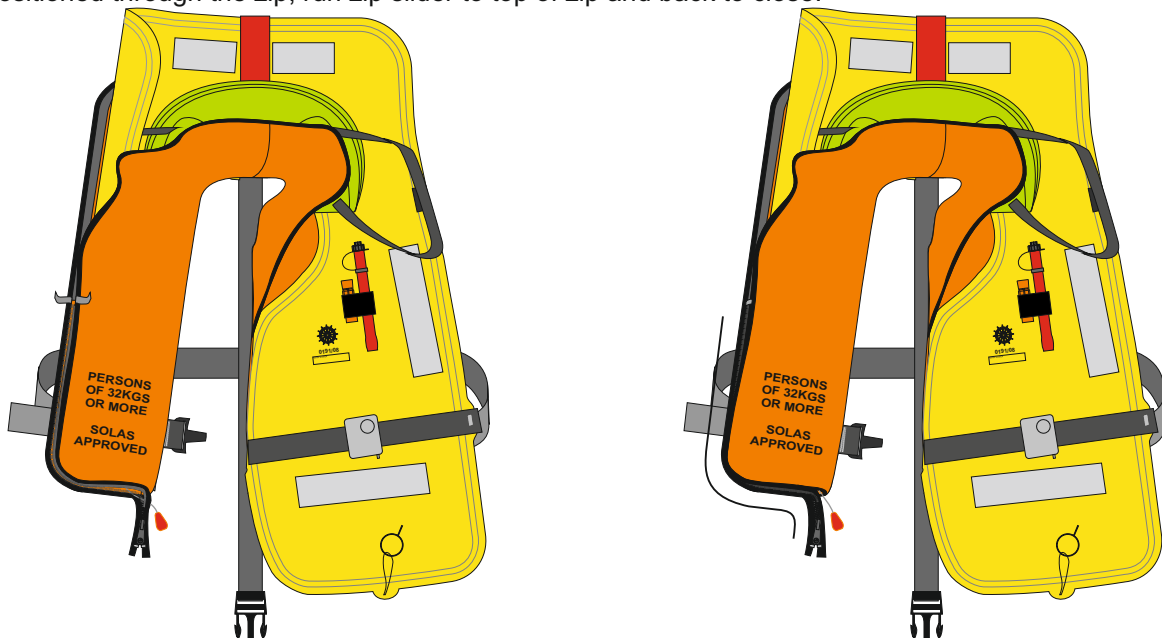

8.3 Seacrewsader Packing Instructions

7

Fold up the bottom of the inflation chamber as shown, and connect the light by inserting the plug. Fold up again the bottom of the inflation chamber in line with the base of the cover. The fold will obscure the light. Move the light upwards and over to the centre seam of the cover. The domed lens of the light should be just visible as shown below.

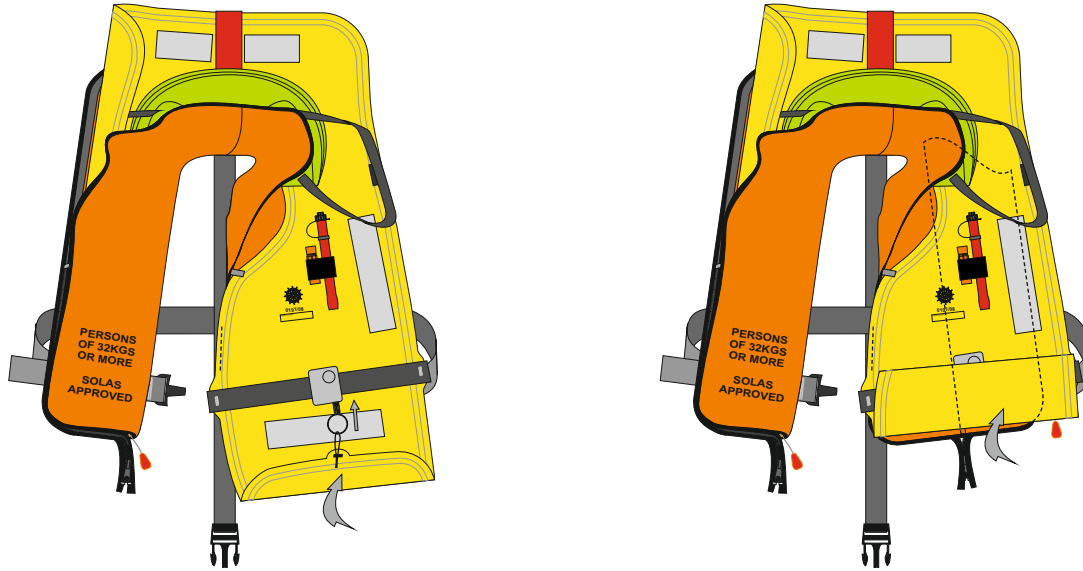

8

Fold the outside edge of the inflation chamber to reveal the operating mechanism. The fold of the chamber should be parallel to the side of the cover. Note: the operating mechanism lever should be below the light unit. Fold over the inside edge of the chamber. This fold should be loosely laid off the top of the fold already made.

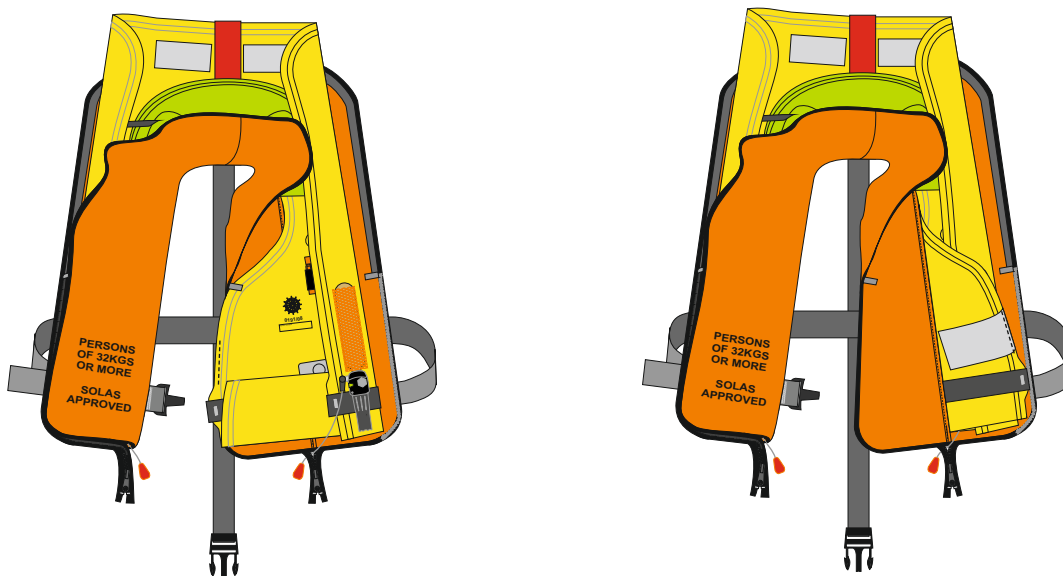

8.3 Seacrewsader Packing Instructions

9

Fold the lower section of the cover over and close the velcro tabs. Ensuring that the firing cord and toggle is positioned through the zip, run zip slider to top of zip and back to close.

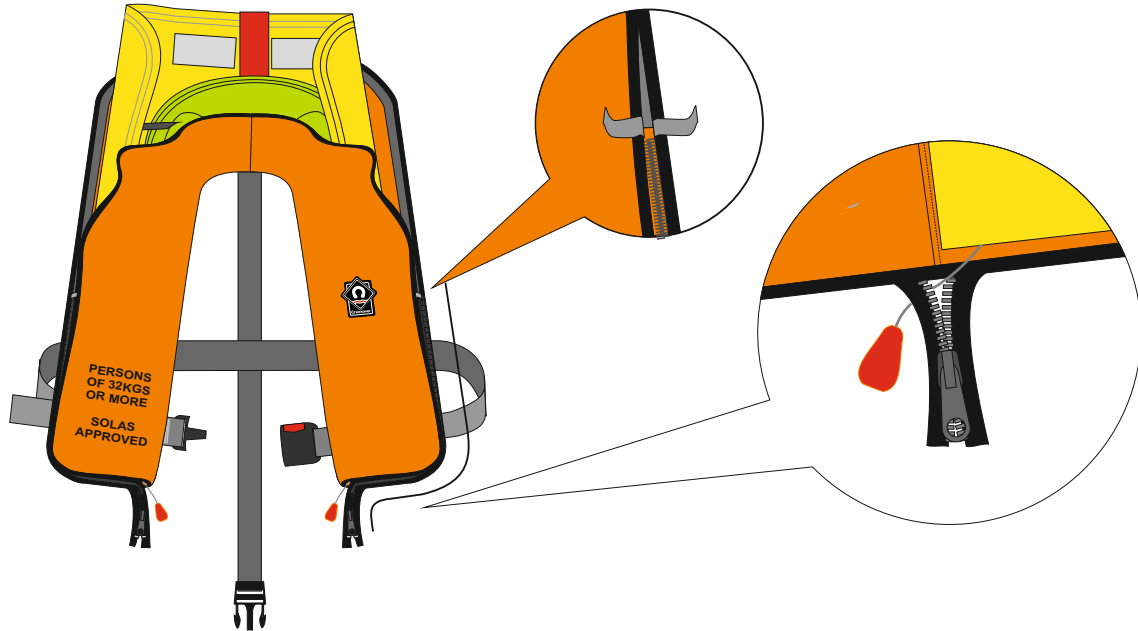

10

Concertina fold the top of the inflation chamber twice - folding over the top of the sprayhood. Ensure that the central red retaining webbing is positioned in the centre and not twisted. Close the remainder of the cover pressing the velcro closures firmly together. Ensure that no part of the inflation chamber is visible. Tuck flying ends of zips complete with slider into the bottom of the lifejacket cover.

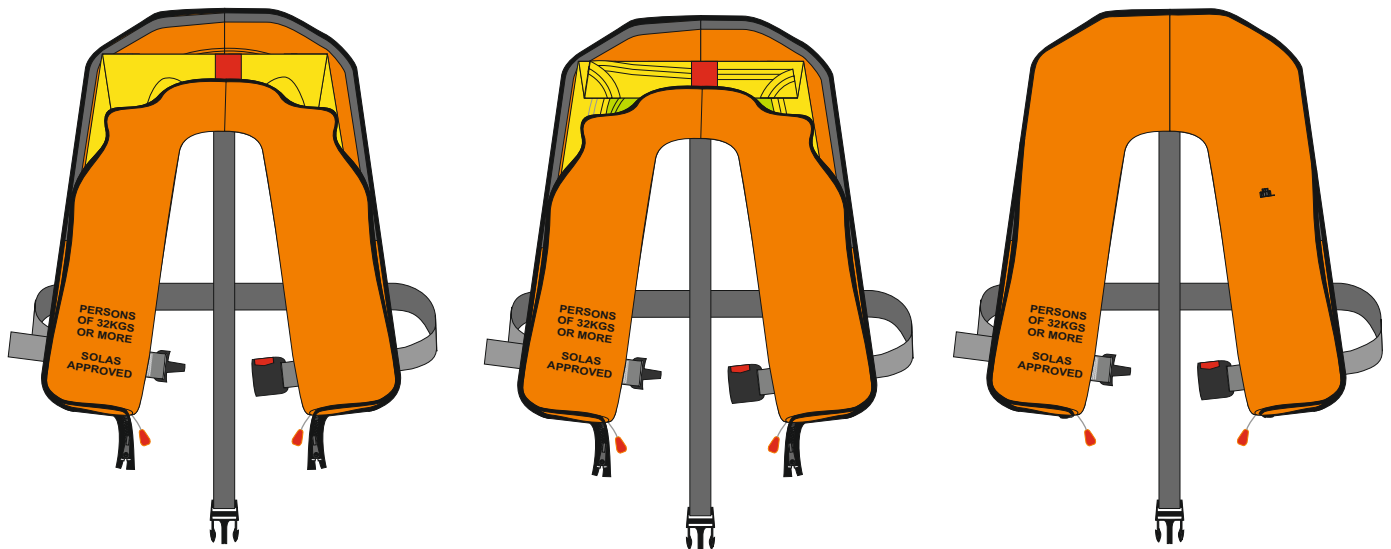

8.4 Hermetically Sealed Bag Packing Instructions

- 8.4.1 When packing a Lifejacket into a Hermetically Sealed Bag the following items are required
- 8.3.1.1 1 x 25g Desiccant Sachet
- NOTE: Ensure the desiccant sachets are kept in the airtight container they are supplied in and that it is only opened in the controlled packing area.
- 8.3.1.2 1 x Foil Bag
 - 8.3.1.3 1 x Seacrewsader Self Adhesive bag label
 - 8.3.1.4 1 x Packed Seacrewsader 275N Twin Lifejacket
- 8.4.2 The Controlled packing area must be dry and clean. Relative humidity should be 20-25% and ambient temperature of 18-23°C.
- 8.4.3 Prepare bag for label application. The self-adhesive label has a perforation line running horizontally across the label; this perforation line must be aligned with the notches on the sides of the foil bag when applied. Check the print is legible before applying the label.
- 8.4.4 Tick the correct option boxes that relate to the Seacrewsader that is being packed. Options below.
- NOTE: This may not appear on some labels, continue to 8.4.5 if the options are not available.
- 8.3.4.1 Standard Waist Belt and Hood
 - 8.3.4.2 Standard Waist Belt and Without Hood
 - 8.3.4.3 Deck Harness EN1095 and Hood
 - 8.3.4.4 Deck Harness EN1095 and Without Hood
- 8.4.5 Fill in the Lifejacket Serial number, light expiry date and automatic capsule expiry date (this is five years from date of packing even if capsule does not match) in relevant spaces on the label using a black waterproof pen. In the date of manufacture area, put a line through the boxes that correspond with the month and year it is packed into the bag. Also in the top left hand corner fill in the box below the Ships Wheel with the last two digits of the year. e.g 09 for 2009.
- 8.4.6 Follow the Seacrewsader packing specification to prepare the lifejacket for insertion into the foil packing bag. **IMPORTANT: Exceptions to a packed lifejacket** - Make sure the Waist Belt buckle is left open and that the Waist Belt is adjusted to its largest size. Fold the end of the Waist Belt back on itself and into a Waist Belt tidy creating a loop for the user to easily grab hold of quickly during Emergency donning. Leave the crutch strap buckle closed but with enough slack to adjust quickly.
- 8.4.7 Ensure the Lifejacket is fully dry. Put the Lifejacket in the foil bag with the desiccant sachet.
- 8.4.8 Try to push as much air out of the bag as possible. Seal the bag immediately after placing the desiccant sachet in the bag. Make sure there is no creases in the bag seal. If there is the bag must be sealed again parallel to the last weld. Make sure that all of the Lifejacket lies inside the bag below the weld line.
- 8.4.9 When batches of Lifejackets have been packed and are ready to dispatch visually inspect all bags.
- 8.4.10 Make sure the desiccant sachets are kept away from any damp areas and the bags are always rolled closed in between use to prevent excess air getting into them. Always reseal the bags of desiccant after use trying to remove any excess air in the bag.

9.1 Parts List

Product Description	Part Number
60 gram CO ₂ Cylinder	10475
UM Mk5 Auto Head	11044
UM Mk5i Auto Capsule	11042
UM Mk5 Auto Head Retaining Clip	11043
UM Mk5 Auto Head Cutter 'O' Ring	11048
Auto Head Retaining Clip	11043
Auto Head Sealing Gasket (Top and Bottom)	10373
Crewsaver Mk5 Auto Head Cylinder Sealing Gasket	10381
Hammar Automatic Cap	11014
Hammar Back Plate	11013
Whistle	10677
CSL Light	10226
Mouth Inflation Valve	10208
Mouth Inflation Valve Cap	10151
Schraeder Valve	10049
1.5psi Pressure Relief Valve	R31201
Cover Fabric for minor repairs	R76178
20mm Loop Velcro	R74801
20mm Hook Velcro	R74802
32mm Elastic	R74300
8 Plait Polyester Cord (White) for Whistle	R71000
8 Plait Polyester Cord (Black) for Light Cord	R71050
Venus Bonded Nylon Thread 40 Orange for cover	R09040
Venus Bonded Nylon Thread 20 Black for flags	R10700
50mm Self Adhesive Retro reflective Tape	R47700
Spiral Zip cut to length for cover closure	R13850
Owners Manual	R18250
Retaining Nut	11047
Foil Bag (including label and desiccant sachet)	10113

10.1 Service Bulletins

Bulletin No 26	Seacrewsader	Issued June 2009
Bulletin No 27	Seacrewsader Pull cords	Issued 23/06/09