



Crewsaver®

SERVICE MANUAL

CREWFIT 150N LIFEJACKET

Crewsaver®

Survitec House, Lederle Lane, Gosport,
Hants. PO13 0FZ, England.
Tel: +44 (0) 1329 820000 Fax: +44 (0) 1329 236218
email: crewsaver@survitecgroup.com
Web: www.crewsaver.com

 **survitecgroup**

Service Bulletins and Amendments Register

No.	Description	Date
Issue 12	Section outlining the scope of the Manual added on Index page.	June 2011
Issue 13	<p>Details of all Automatic Heads, Capsules and Indicator Clips used.</p> <p>Information from Bulletin 37 regarding manifold types now included.</p> <p>Information from Bulletin 38 regarding checking the Gas Flange and Inflation Tube on older jackets now included.</p> <p>Requirement for Servicing personnel to mark Service Labels with initials and certificate number added to Section 8.1.6.</p> <p>Details of CSL Light added to Section 5</p>	February 2013
Issue 14	<p>Page 4 - change in procedure for accessing manuals on the website.</p> <p>Section 8.1.3.3 - New procedure for fitting replacement cylinders to Hammar mechanism.</p> <p>Section 5.9 and Section 6.5 - Expired L6 Lights to be replaced by CSL Lights.</p> <p>CSL Light added to Parts List</p>	March 2014
Issue 15	<p>Reference to Venturi Vacuum System added (sections 6.1.2, 8.1.2 and Parts List)</p> <p>Back pressure test added</p>	November 2016

Scope

This manual covers primarily the servicing of the Crewfit range of 150N lifejackets. The elements contained within the manual also cover other types of lifejacket as listed below. Training will have been given in these lifejackets and if any aspect is critical to its operation this will be shown in this manual.

1. Corporate Lifejacket
2. Bailiff Lifejacket
3. Pouch Lifejacket
4. Seavest Lifejacket

Index

Section 1	1.1	Introduction
	1.2	Product Description
	1.3	Data Sheet
	1.4	General Features
	1.5	Donning Instructions
Section 2	2.1	Service Station Guidelines
	2.2	On Receipt Inspection
	2.3	General Care
	2.4	Servicing Tools
	2.5	Lifejacket Servicing Record Sheet
Section 3	3.1	Unpacking the Lifejacket
Section 4	4.1	Cleaning Lifejackets
Section 5	5.1	Inspection
Section 6	6.1	Testing
Section 7	7.1	Repairs
Section 8	8.1	Assembly
Section 9	9.1	Replacement Parts

1.1 Introduction

- 1.1.1. This Service Manual will be published on the Crewsaver website (www.crewsaver.com). Click on PARTNER /LOGIN at the top of the screen. Personnel who have been trained in the servicing procedures for this lifejacket will be issued with a Username and Password to enable them to access the download section. Each manual carries an Issue Number and records of issue are logged by Crewsaver to ensure that the service network maintains correct and up to date servicing information. Emails will be sent regarding any new Issues. Periodically service bulletins may be issued which will be published on the Crewsaver website (www.crewsaver.com). Emails will also be sent. It is the service station's responsibility to regularly check the website for any new bulletins and to ensure inclusion within the servicing manual. The service bulletin register at the front of the Manual should be completed.
- 1.1.2. The information referenced in each section follows a standard servicing procedure by which the inspection should take place.
- 1.1.3. This servicing manual details information to enable regular maintenance and servicing of the lifejacket to help prolong the life of the product and ensure it functions correctly.
- 1.1.4. The manual should be used as a reference document following training in servicing procedures instructed by Crewsaver approved personnel. The manual also details the equipment and parts needed for correct maintenance to be performed.
- 1.1.5. Servicing must be carried out annually at a service station authorised by the manufacturer 
- 1.1.6. Regular servicing is to be carried out by qualified personnel trained by Crewsaver and holding a valid servicing certificate. Certificates are valid for a period of 3 years.

1.2 Product Description

- 1.2.1. The Crewfit 150 is a single chamber 150N inflatable lifejacket.
- 1.2.2. The lifejacket is CE approved to EN 396 -150N Lifejackets.
- 1.2.3. The lifejacket is easy to don.
- 1.2.4. The buoyancy of the jacket is provided by a single chamber with an oral tube to ensure the full buoyancy can be achieved upon or after inflation.
- 1.2.5. This lifejacket is inflated either manually or by automatic firing mechanisms.
- 1.2.6. This lifejacket comes in two different versions, the waist belt version and integral deck safety harness version which are both available with either a velcro or zipped cover closure.
- 1.2.7. The outer cover is made from a hard wearing material. The colour of the outer cover is normally red or navy blue. The cover can sometimes be in other colours, e.g. green or black, to meet special customer requirements.
- 1.2.8. The Crewfit Junior is fitted with anti-tamper devices. These are white plastic tubes which cover the cylinder and capsules.

1.3.1 Data Sheet

Features:	Crewfit 150N Lifejackets
Chamber Buoyancy:	160N
Buoyancy Category:	150N
Cover Colour	Red, Blue or Black
MCA (UK) Approved	-
SOLAS Approved	-
CE Approved	X
Cylinder size	33g
Standard Automatic	According
Hammar Automatic	to customer
Manual Firing head	choice
Manual Override	X
Oral inflation tubes	X
Pressure relief valves	N/A
Hard wearing cover	X
Whistle - fitted	X
Retro-reflective tape	X
Lifting Becket - fitted	X
Light - fitted	Optional
Spray Hood	Optional
Thigh straps - fitted	X
Fall Arrest Harness	N/A
Closure method	Velcro or Zip
Alternative covers	Fireproof, Heavy Duty

1.3.2 Data Sheet

Features:	Crewfit 150N Junior Lifejackets
Chamber Buoyancy:	100N
Buoyancy Category:	150N
Cover Colour	Red or Navy
MCA (UK) Approved	-
SOLAS Approved	-
CE Approved	X
Cylinder size	23g
Standard Automatic	X
Hammar Automatic	-
Manual Firing head	-
Manual Override	X
Oral inflation tubes	X
Pressure relief valves	N/A
Hard wearing cover	X
Whistle - fitted	X
Retro-reflective tape	X
Lifting Becket - fitted	X
Light - fitted	Optional
Spray Hood - fitted	-
Thigh straps - fitted	X
Fall Arrest Harness	N/A
Closure method	Velcro
Alternative covers	-
Anti tamper devices on cylinders and capsules	X

1.4.1 General Features - Crewfit 150 Non Harness

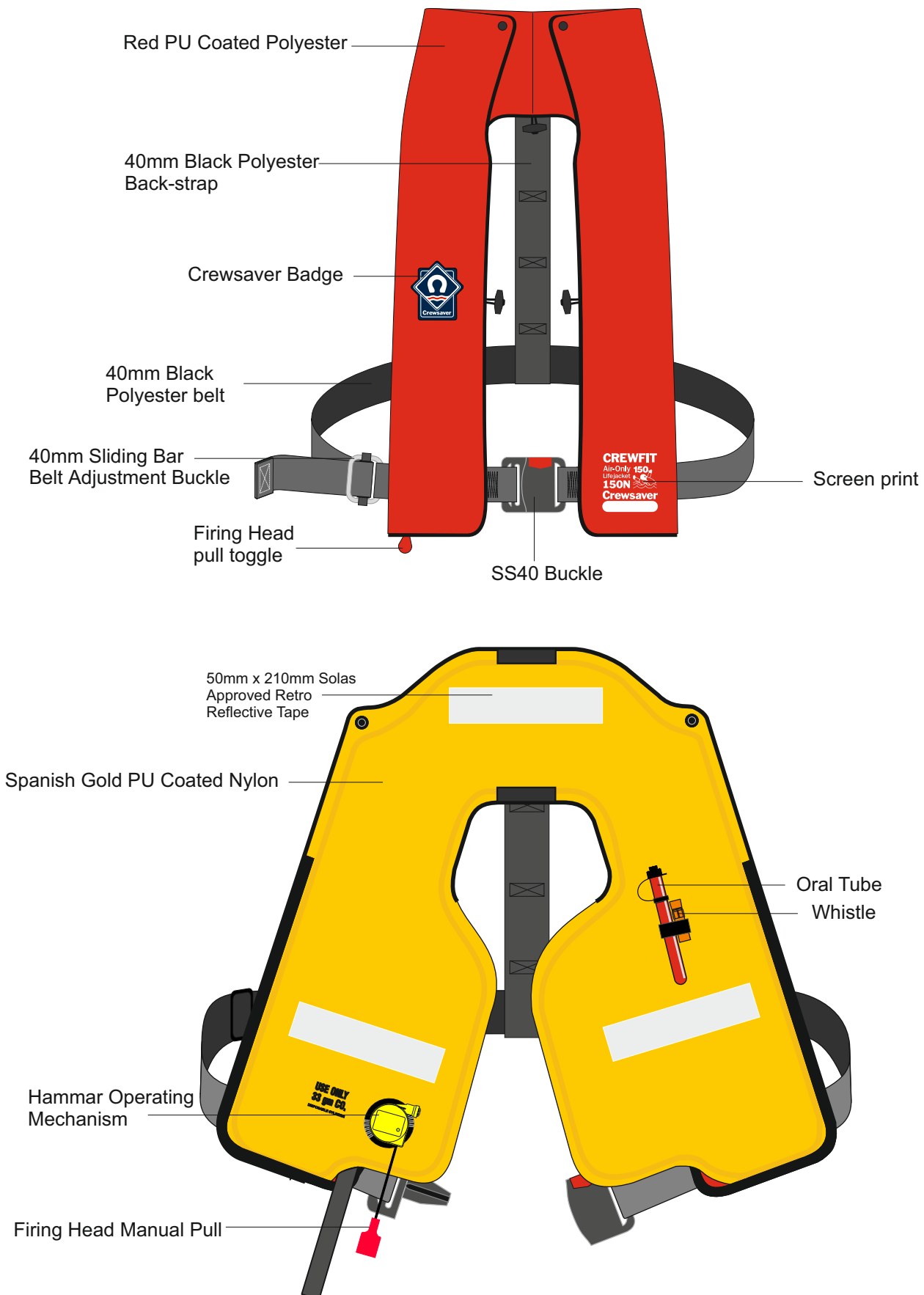

1.4.2 General Features - Crewfit 150 Harness

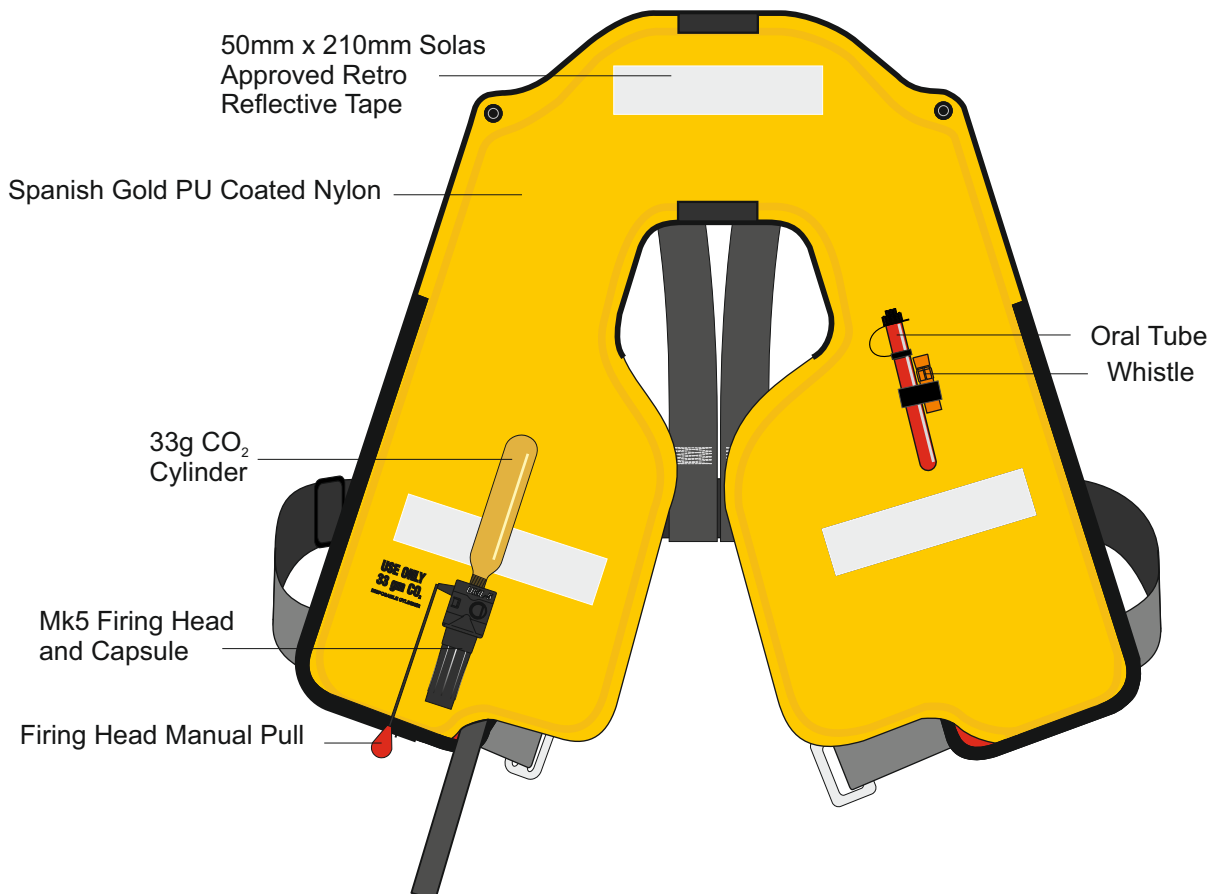
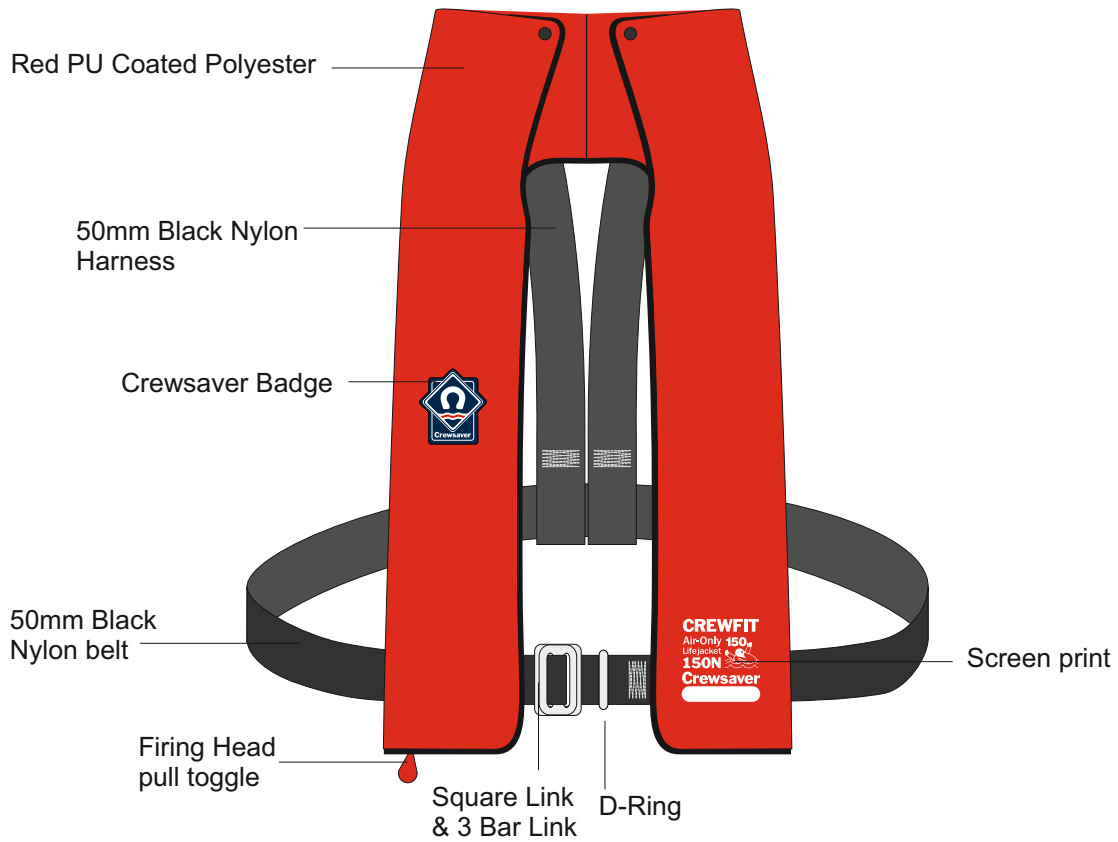

1.4.3 General Features - Crewfit Junior Non Harness

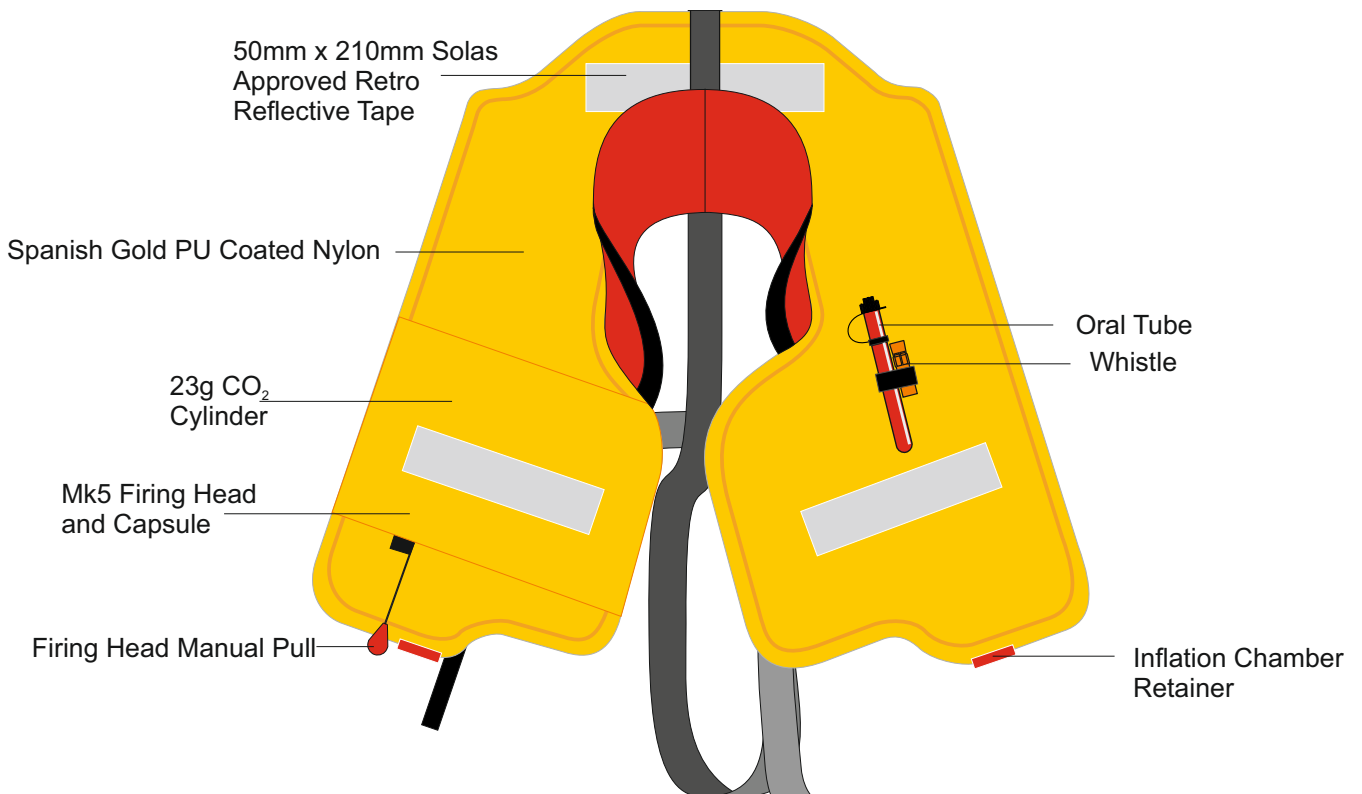
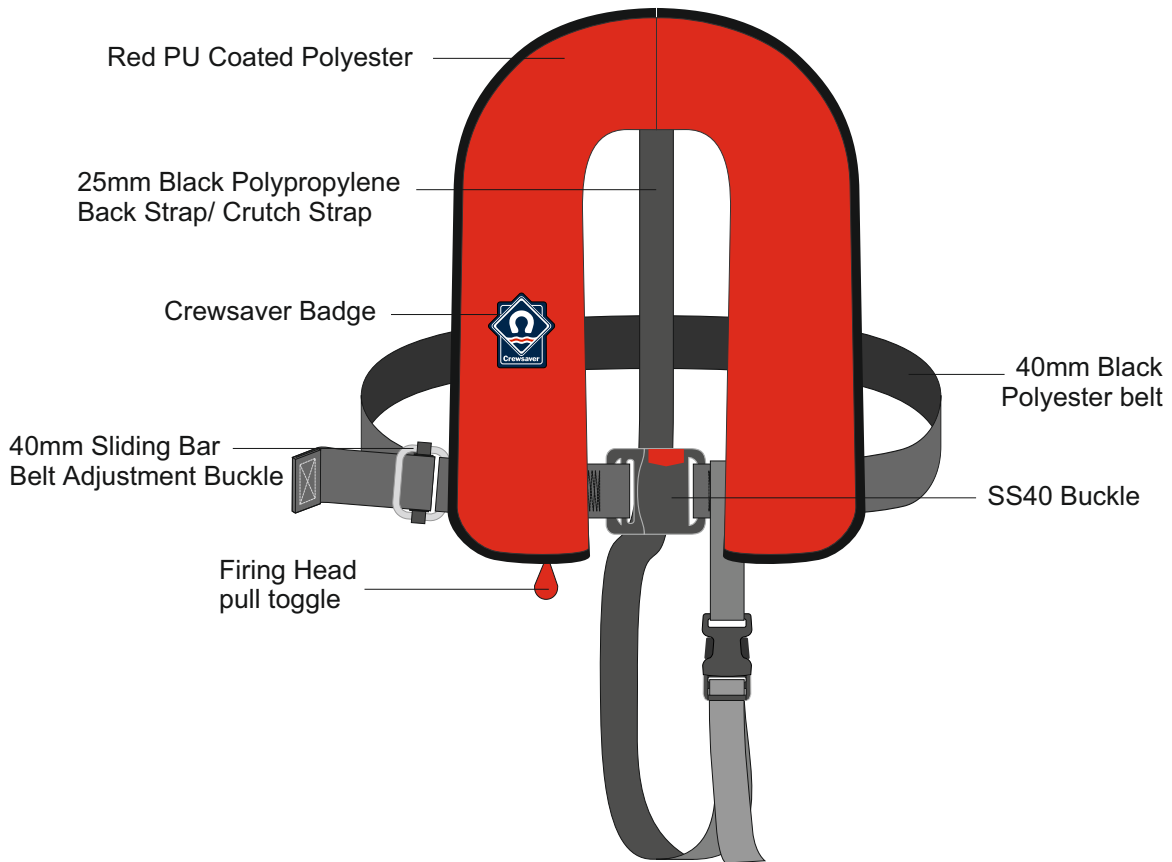

1.4.4 General Features - Crewfit Short Non Harness

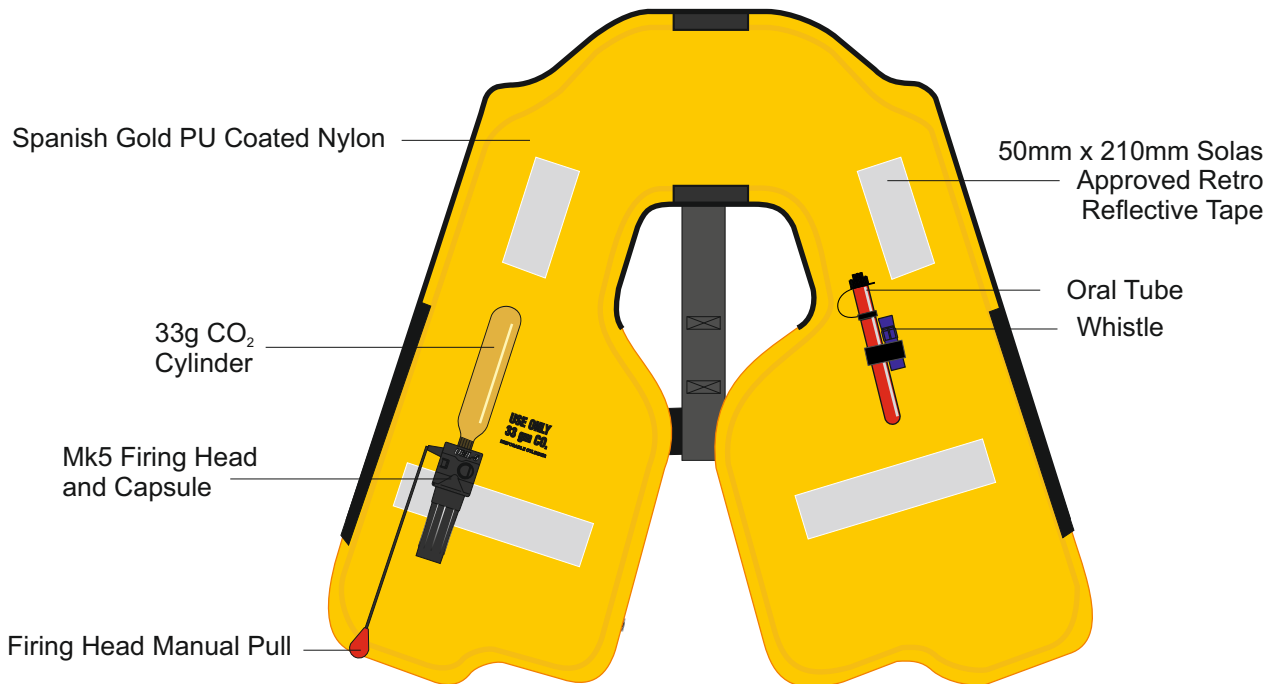
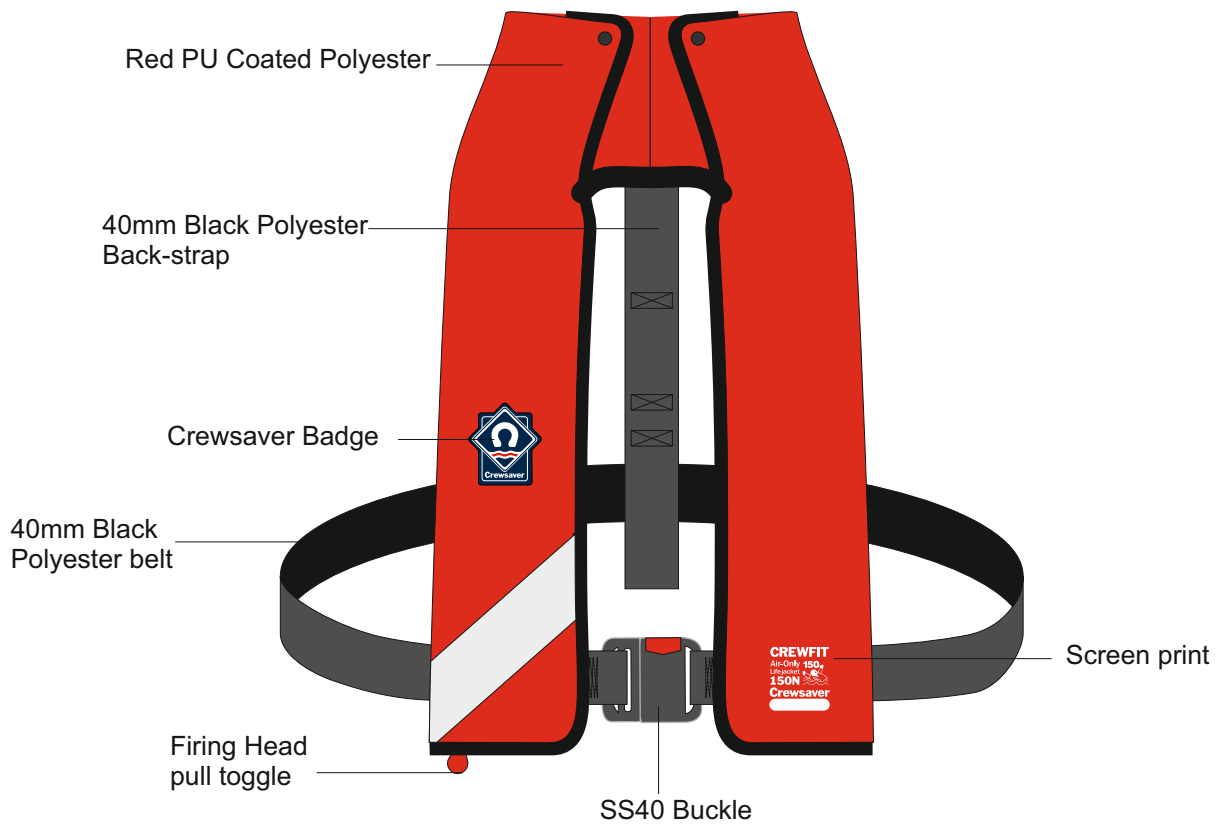

1.5.1 Donning Instructions - Crewfit 150 Non-Harness

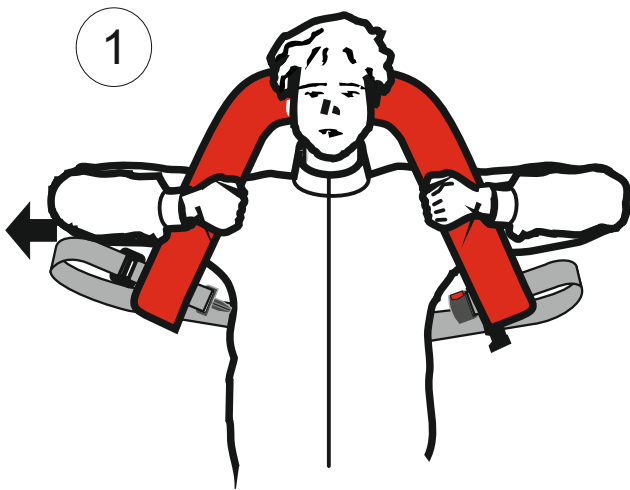

Don the lifejacket like a normal jacket

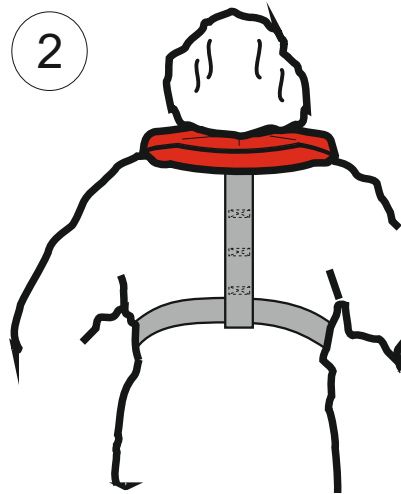

The backstrap should then be positioned down the centre of the back.

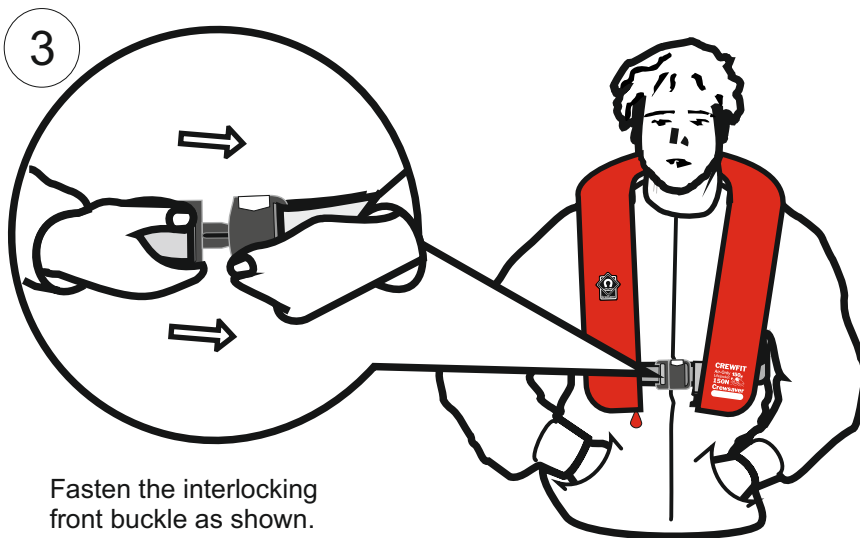

Fasten the interlocking front buckle as shown.

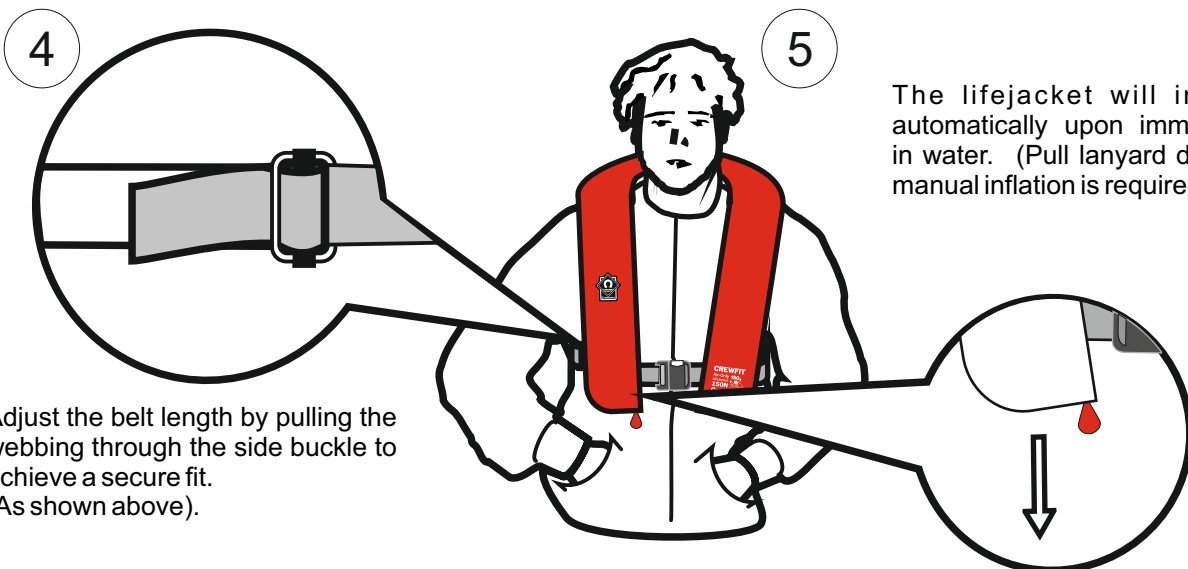

Adjust the belt length by pulling the webbing through the side buckle to achieve a secure fit. (As shown above).

The lifejacket will inflate automatically upon immersion in water. (Pull lanyard down if manual inflation is required).

1.5.2 Donning Instructions - Crewfit 150 Harness



Don the lifejacket like a normal jacket

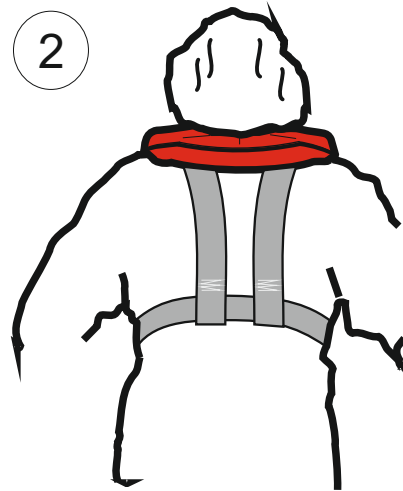

The shoulder straps should then be positioned down the centre of the back.

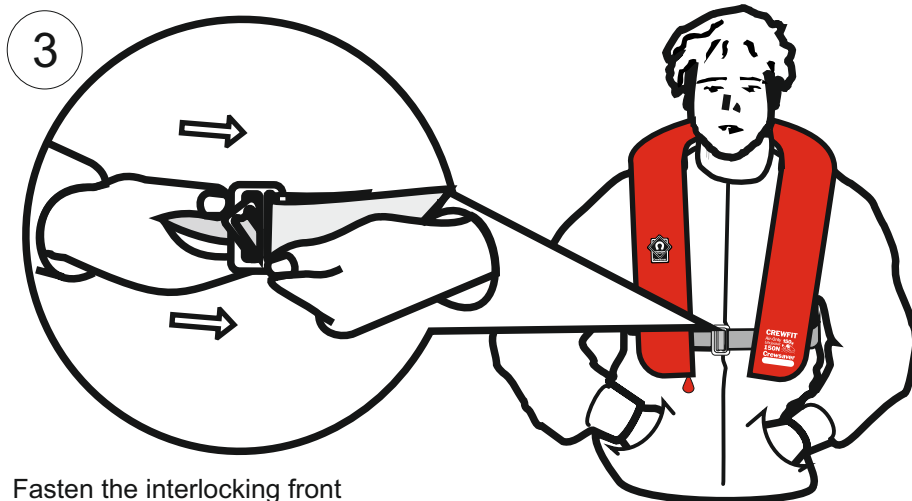

Fasten the interlocking front buckle as shown.

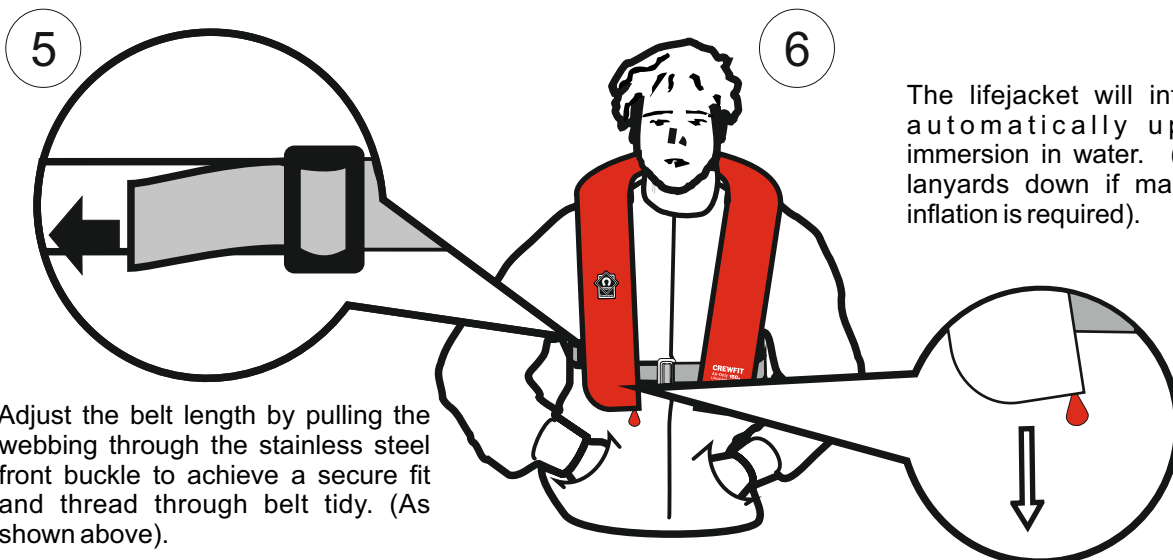

Adjust the belt length by pulling the webbing through the stainless steel front buckle to achieve a secure fit and thread through belt tidy. (As shown above).

The lifejacket will inflate automatically upon immersion in water. (Pull lanyards down if manual inflation is required).

2.1 Service Stations

- 2.1.1 Service stations shall comply with the following as a minimum;
 - 2.1.1.1 Servicing of Inflatable Lifejackets shall be carried out in a fully enclosed area only.
 - 2.1.1.2 The area shall be well lit and protected from direct sunlight.
 - 2.1.1.3 The temperature and humidity shall be sufficiently controlled to ensure that the servicing of inflatable Lifejackets may be carried out successfully.
 - 2.1.1.4 The area shall be efficiently ventilated but free from draught.
 - 2.1.1.5 Sufficient tools (including specialist tools) shall be available to ensure Lifejackets may be disassembled, tested and reassembled in accordance with this Manual. These shall include but not limited to:
 - 2.1.1.5.1 Manometers and pressure gauges.
 - 2.1.1.5.2 Oil free and dry air supply.
 - 2.1.1.5.3 Scales for weighing Gas Cylinders.
 - 2.1.1.5.4 Crewsaver Service tool kit (See 2.6). This is recommended but similar calibrated devices may also be used.
 - 2.1.1.6 Stock of materials and components to allow efficient servicing with readily available replacement parts to ensure a prompt service for the customer.
 - 2.1.1.7 Only personnel trained and certified in accordance with Crewsaver requirements are approved to carry out Servicing and Maintenance. They must be holders of a valid Certificate issued by Crewsaver.
 - 2.1.1.8 The service station shall be of an approved standard.
 - 2.1.1.9 Procedures shall be introduced to ensure that service bulletins, Manuals and replacement parts are obtained from Crewsaver.
 - 2.1.1.10 Subsequent to initial approval and thereafter the service station shall be subject to regular surveillance by Crewsaver.
 - 2.1.1.11 The service station must comply and have met all QA criteria in the Crewsaver servicing protocol file.

2.2 On Receipt Inspection

- 2.2.1 On receipt of the Lifejacket(s), check the state of the packaging before opening and notify the owner and the company delivering the package of any defects or damage.
- 2.2.2 On opening the package, check the contents for their general condition and quantity.
- 2.2.3 Prepare Servicing Record Sheet.
- 2.2.4 Visually inspect the cover and inflation chamber for damage, abrasion, contamination etc. In accordance with this manual.
- 2.2.5 Note repairs or replacements required on the record sheet.
- 2.2.6 Unless obvious damage is evident, test the Lifejacket in accordance with Section 6. If it is considered that the damage found would cause the Lifejacket to fail the tests then corrective action shall be carried out prior to testing.
- 2.2.7 Damaged areas shall only be marked using wax based crayon. Marks shall be with a small circle or cross. Ballpoint, rollerball or other forms of ink shall not be used. If in doubt refer to Crewsaver for guidance.
- 2.2.8 Repairs to the outer cover are limited to that detailed in section 7.1.
- 2.2.9 Repairs to welded components including the inflation chamber are expressly forbidden.

2.3 General Care

- 2.3.1 The Lifejacket should be stowed in accordance with the manufacturer's instructions.
- 2.3.1.1 Lifejackets should be stowed in a dry compartment. Avoid high humidity, such as a car boot.
 - 2.3.1.2 Automatic Lifejackets should have stowage facilities which are provided with a method to encourage moisture removal.
 - 2.3.1.3 Lifejackets should be stowed vertically, for example hung on hooks, in order that any trapped water or condensation can drain away naturally.
 - 2.3.1.4 Lifejackets should be rinsed in fresh water and dried thoroughly after use.

WARNING

Prior to sponging or washing remove automatic capsules from the firing mechanism. Allow to dry thoroughly afterwards.

- 2.3.2 Contaminants such as oil or diesel fuel may be sponged off immediately with clean water and allowed to dry naturally.
- 2.3.3 Mud can be removed with a stiff (not wire) brush when dry.
- 2.3.4 The outer cover may be hand washed in good quality mild detergent in cool water (40°C). Rinse well, drip dry naturally in air.
- 2.3.5 Sponge the inflation chamber with pure soap solution only. Rinse in clean water immediately, inflate and allow to dry naturally in air.

WARNING

Do not use proprietary cleaning fluids, thinners, spirits or similar substances.

- 2.3.6 In cases of severe contamination the unit shall be deemed beyond economic repair and the customer advised to purchase a replacement lifejacket.

WARNING

Make sure you know how to use and fit this Lifejacket before an emergency occurs. Always try and inflate the Lifejacket in the water. If already inflated, cross arms over the chest before jumping.

- 2.3.7 It is advised that personnel are familiarised with the operation of all Lifejackets and lifesaving appliances.

2.4 Lifejacket Servicing Tools

Fig. 2.4 Table of Tools Required

Description	Type
Crewsaver Servicing Tool Kit A fine screw driver or tool suitable for removing gaskets Boning tool Roller Brushes Scissors or good quality trimming shears "Chinagraph" pencil Tailors chalk Fine point indelible pen 1 off metal calibrated metre stick Scales to weigh gas cylinders Adaptor/tee piece for testing inflation chambers. Manometer Timing Device Thermometer Crewsaver Vemnturi Vacuum System Clean and dry air supply 1 off ball pein hammer 450mm wide bag sealer (3mm element) Back pressure test unit	0-1000gram (+1/-1 grams) 0-500Mbar 0-40°C
Suitable large surface area for the work to be carried out 1 off FR steel cabinet (adhesive store) 1 off HD industrial sewing machine (e.g. Singer 96K, Juki, Durkopp etc.)	
<p><i>N.B. In case of difficulty contact Crewsaver direct (Not sewing machines, cabinets or tables - these parts may be sourced locally.)</i></p>	
<p><i>Note: Prior consent to carry out any repairs must be pre-approved by Crewsaver. All repairs to stitching must be in accordance with this manual.</i></p>	

2.5 Lifejacket Service Record Sheet

- 2.5.1. An electronic copy of the sheet is available to aid reproduction (or copy next page).
- 2.5.2. Each lifejacket serviced should be recorded either individually or as a batch, showing the serial numbers and the work performed during the service.
- 2.5.3. The service record sheet should be signed and a copy given to the owner certifying that the lifejacket has been serviced.
- 2.5.4. All replacement parts should be noted - recording either the serial numbers of the component or the expiry date.
- 2.5.5. The record sheet shown on the next page is a recommended version. Similar record sheets, including the same information, may also be used.



CERTIFICATE NUMBER:

LIFEJACKET SERVICING SCHEDULE

W/O Number:

TYPE	
CUSTOMER	
VESSEL	
LAST SERVICED BY	DATE OF LAST SERVICE

SERIAL NUMBER/S:

CHAMBER INSPECTION	<input type="checkbox"/> <input checked="" type="checkbox"/>	COMMENTS
GENERAL CONDITION		
MATERIAL		
WELDS		
WEBBINGS		
RETRO TAPE		
WHISTLE		
ORAL TUBES		
RELIEF VALVES		
MANIFOLDS		
Schrader VALVES		
CYLINDERS		
LIGHT		
CYALUME POCKET		
BUDDY LINE		

INFLATION MECHANISM	<input type="checkbox"/> <input checked="" type="checkbox"/>	COMMENTS
OPERATING MECHANISM		
CORD		
AUTOMATIC CAPSULE		
WASHERS		
RETAINING NUT		
RETAINING CLIP		
TOGGLE		

SPRAY HOOD	<input type="checkbox"/> <input checked="" type="checkbox"/>	COMMENTS
FABRIC		
ATTACHMENT		
VELCRO		

WEBBINGS	<input type="checkbox"/> <input checked="" type="checkbox"/>	COMMENTS
WAIST BELT / HARNESS		
BACK STRAP		
LIFTING BECKET		
CROTCH STRAP		
BUCKLES		
STITCHING		

COVER	<input type="checkbox"/> <input checked="" type="checkbox"/>	COMMENTS
MATERIAL		
VELCRO		
ZIP		
PLB POCKETS		

PRESSURE TEST RESULTS

TIME		FRONT CHAMBER	REAR CHAMBER
ON			
OFF			
TEMP.		ON	OFF

RELIEF VALVE TEST RESULTS

	FRONT CHAMBER	REAR CHAMBER
OPEN		
CLOSE		

REPAIRED ITEMS (COMMENTS)

SERVICED BY:

DATE:

2.6 Lifejacket Servicing Tool Kit



Cylinder Torque Strap

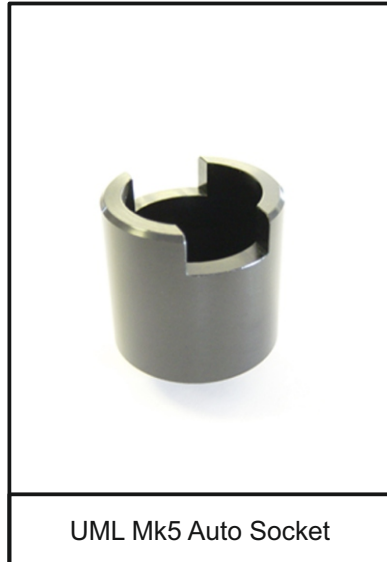

UML Mk5 Auto Socket



Manometer



Valve Extraction Tool

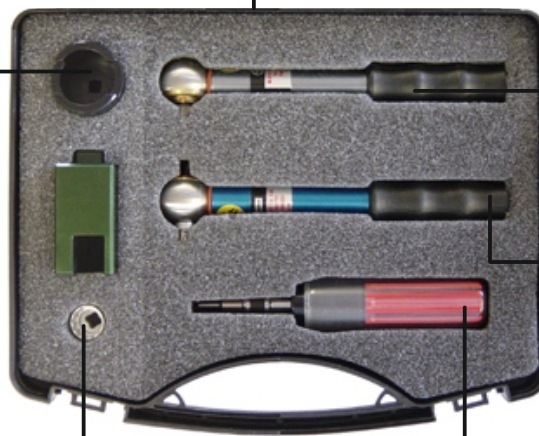

Turned Socket



Inflation Adaptor

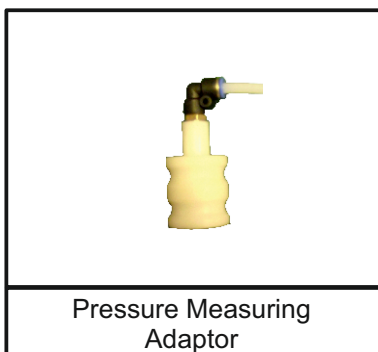

Pressure Measuring Adaptor



Calibrated Socket Driver (Tighten Cylinder)



Calibrated Socket Driver (Remove & Replace Locking Nuts For UML & HR)



Calibrated Torque Driver (Schraeder Valve)

3.1 Unpacking

- 3.1.1 Starting at the inflation mechanism side of the outer cover, un-peel the velcro or pull the zips apart (zipped version only), exposing the operating head and cylinder. Care should be taken not to snag the firing line. See Fig 3.1 for Adult version & Fig 3.2 for Junior version.

WARNING: All defects should be noted onto the service record sheet.

- 3.1.2 Remove the operating mechanisms.

- 3.1.2.1 Following unpacking refer to:

- a.) Manual Operation: Fig 3.3 - Halkey Roberts operating head removal.
- b.) Automatic Operation: Fig 3.4 - Crewsaver Mk5 Automatic operating head removal.
- c.) Automatic Operation: Fig 3.6 - United Moulders Mk3 Automatic operating head.
- d.) Automatic Operation: Fig 3.7 - United Moulders Mk5 Automatic operating head.

- 3.1.2.1.1 Automatic Only. Unscrew the Automatic Capsule if fitted from the operating mechanism. Place to one side for testing and reassembly later. See Section 6 for details.

- 3.1.2.1.2 Carefully remove the inflation cylinder by unscrewing it from the operating mechanism. Retain for further Inspection. Refer to Section 5.

- 3.1.2.1.3 Remove Operating Mechanisms (and upper and lower manifold gaskets on Halkey Roberts operating heads only) by unscrewing the retaining nut on the top of the inflation mechanism. Retain for further Inspection. Refer to Section 5.

- 3.1.2.2 If a Hammar operating mechanism is fitted, remove using the special Hammar operating head "Service Key". See Fig 3.8. Place to one side for further inspection. Refer to Section 5.

- 3.1.3. Remove light and battery if fitted and if required. Place to one side for further inspection. Refer to section 5.
- 3.1.4. For Cleaning. Refer to Section 4.
- 3.1.5. Carry out visual inspection. Refer to section 5.

Fig 3.1 Unpacking the Crewfit 150 Lifejacket

Fig. 3.1.1



Fig. 3.1.2

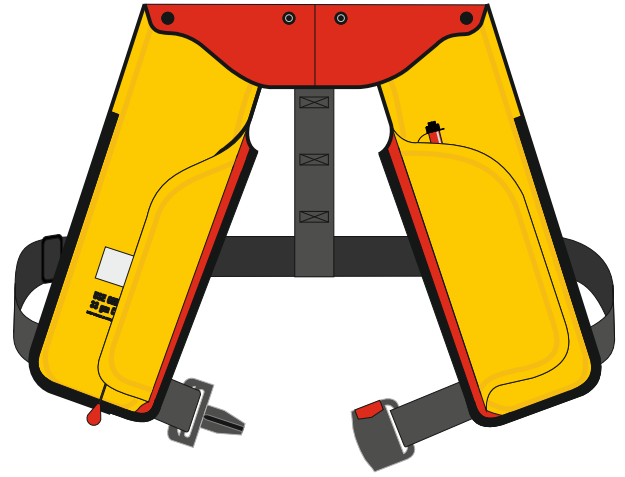

Fig. 3.1.3

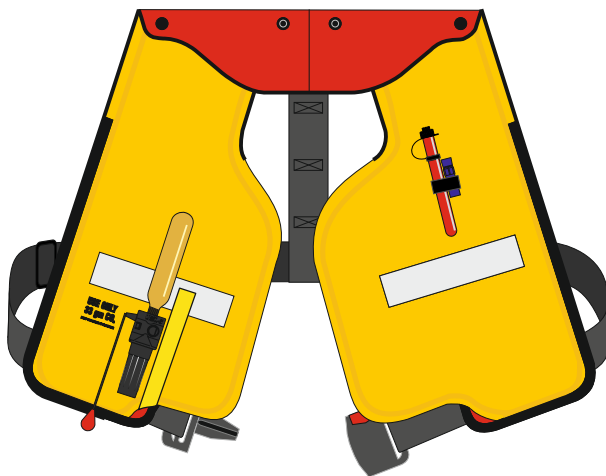

Fig. 3.1.4



Fig 3.2 Unpacking the Crewfit Junior Lifejacket

Fig. 3.2.1



Fig. 3.2.2



Fig. 3.2.3



Fig. 3.2.4

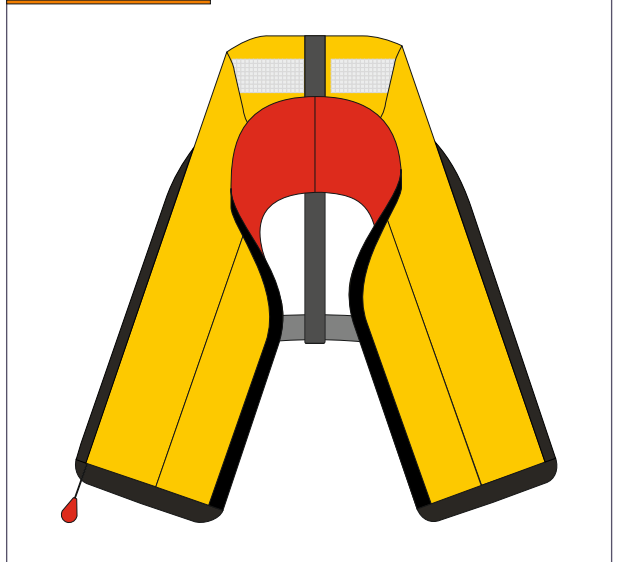

Fig. 3.2.5



Fig. 3.2.6

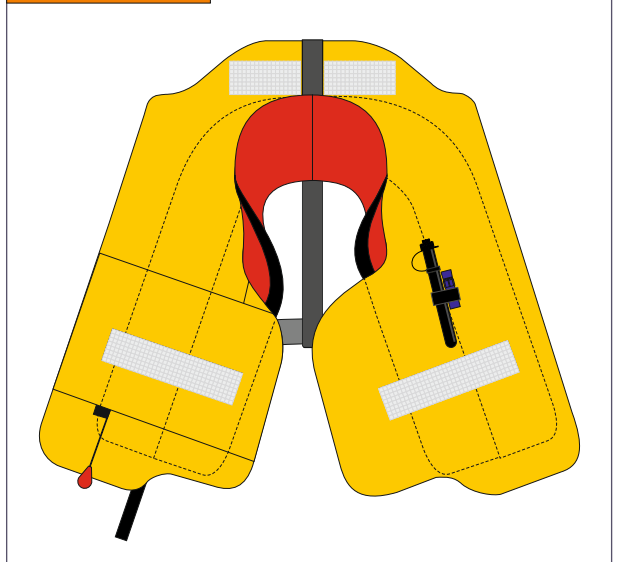
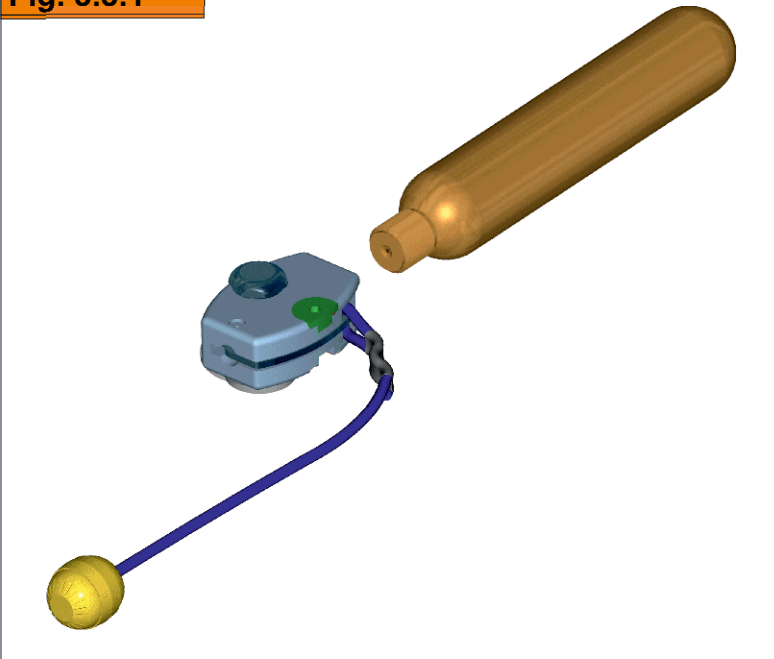

Fig 3.3 Halkey Roberts Operating Head

Fig. 3.3.1



Unscrew the 33 gram cylinder from the manual firing head. Check to see if the cylinder has been used.
 NOTE: This should be performed by check weighing. If under the min. weight as displayed on the cylinder body, discard in a safe manner.

Fig. 3.3.2

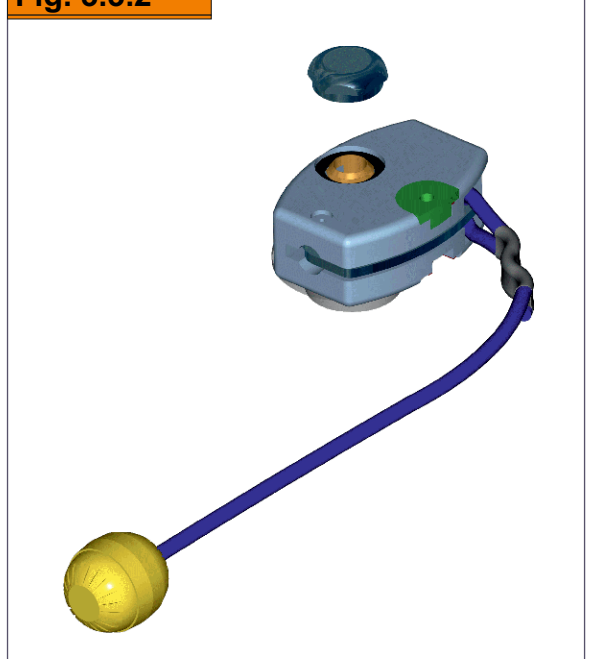

Unscrew the valve retaining nut from the top of the firing head, using a 9/16" socket or spanner. Check for corrosion, discard if corroded. Remove the top sealing gasket/ washer and discard. This must be replaced with a new part upon reassembly.

Fig. 3.3.3

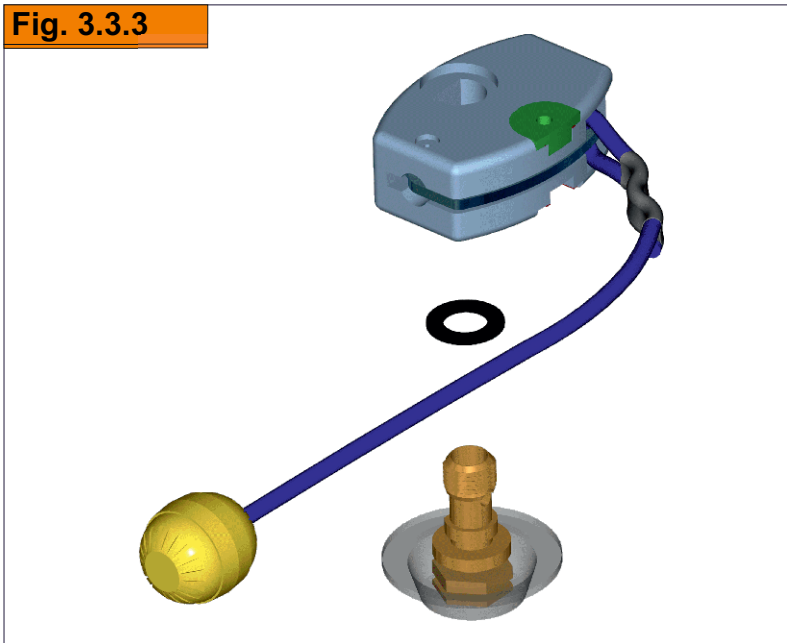

Remove the operating head from the manifold which is welded to the inflator fabric. Remove the bottom gasket / sealing washer and discard. This must be replaced with a new part upon reassembly.

Please Note: The operating head may not match the images above, but the processes are always the same.

STANDARD AUTOMATIC LIFEJACKETS

Lifejackets received for servicing may have various automatic heads and capsules fitted. Below are details of the heads and capsules that may be encountered together with instructions regarding any necessary replacements.



Mk3 Automatic Head.
Fitted to Lifejackets manufactured before 1997.
This head is obsolete and **MUST** be replaced but refer to Service Bulletin 23 regarding replacement.



Crewsaver Mk5 Automatic Head - Yellow.
Fitted to Lifejackets manufactured between 1996 and 2002.
This head is obsolete but is still servicable. If necessary replace with United Moulders Mk5 Auto Head and Capsule - Sales Code 11044.
Uses Crewsaver Mk5i Auto Capsule - Sales Code 10012.



Crewsaver Mk5 Automatic Head - Navy Blue.
Fitted to Lifejackets manufactured from 2002 until early 2012.
This head is obsolete but is still servicable. If necessary replace with United Moulders Mk5 Auto Head and Capsule - Sales Code 11044.
Uses Crewsaver Mk5i Auto Capsule - Sales Code 10012.



United Moulders Mk5 Automatic Head - Black.
Fitted to original batches of CSR 150N, Seacrewsader and House of Hardy Crewfit Lifejackets. The serial numbers are prefixed with 'L'.
This head is obsolete but is still servicable. If necessary replace with United Moulders Mk5 Auto Head and Capsule - Sales Code 11044.
Uses United Moulders Mk5i Auto Capsule - Sales Code 10017.



United Moulders Mk5 Automatic Head - Yellow.
Fitted to all current standard automatic Lifejackets. The serial numbers are prefixed with 'L'.
Sales Code 11044 (Head and Capsule together).



Mk3 Automatic Capsule without shroud.
Fitted to all automatic Lifejackets manufactured up to 2002 (unshrouded version used on Seafire Solas).
This capsule is obsolete and should be replaced with Crewsaver Mk5i Automatic Capsule - Sales Code 10012.



Mk3 Automatic Capsule with shroud.
Fitted to all automatic Lifejackets manufactured up to 2002.
This capsule is obsolete and should be replaced with Crewsaver Mk5i Automatic Capsule - Sales Code 10012.



Crewsaver Mk5 Automatic Capsule - Yellow.
This capsule has been withdrawn and should not be found fitted to any Lifejacket.
If any are found they **MUST** be replaced with Crewsaver Mk5i Automatic Capsule - Sales Code 10012.



Crewsaver Mk5 Automatic Capsule - Navy Blue.
Fitted to Lifejackets manufactured from 2002 until early 2009.
This Capsule is obsolete but is servicable up to the date shown on the Capsule.
When necessary replace with Crewsaver Mk5i Automatic Capsule - Sales Code 10012.



Crewsaver Mk5 Automatic Capsule - Navy Blue.
Fitted to Lifejackets manufactured from early 2009 until late 2011.
This Capsule is obsolete but is servicable up to the date shown on the Capsule.
If the Capsule is still in date fit protective cap R17111.
When necessary replace with Crewsaver Mk5i Automatic Capsule - Sales Code 10012.



Crewsaver Mk5i Automatic Capsule - Navy Blue.
Fitted to Lifejackets manufactured from late 2011 to early 2012.
Sales Code 10012



Crewsaver Mk5i Automatic Capsule - Blue.
Identical to the Capsule shown above. The colour has been changed to differentiate it from the black United Moulders Mk5i Capsule 10017.
Sales Code 10012



United Moulders Mk5 Automatic Capsule - Black.
Fitted to original batches of CSR 150N, Seacrewsader and House of Hardy Crewfit Lifejackets.
This Capsule is obsolete but is servicable up to the date shown on the Capsule.
When necessary replace with United Moulders Mk5i Automatic Capsule - Sales Code 10017.



United Moulders Mk5 Automatic Capsule - Black.
Fitted to Lifejackets manufactured from late 2010 up to 2012.
This Capsule is obsolete but is servicable up to the date shown on the Capsule.
If the Capsule is still in date fit protective cap R17111.
When necessary replace with United Moulders Mk5i Automatic Capsule - Sales Code 10017.



United Moulders Mk5i Automatic Capsule - Black.
Fitted to all Lifejackets manufactured from 2012 onwards.
Sales Code 10017.



Indicator Clip.
Fitted to all Crewsaver and United Moulders Mk5 Automatic Heads EXCEPT the current yellow UM Mk5 head (Sales Code 11044).
Sales Code 10111.



Indicator Clip.
Fitted to the current United Moulders Mk5 Automatic Head - Yellow.
Sales Code 11043.

Fig 3.4 Crewsaver Mk5 Operating Head

Fig. 3.4.1

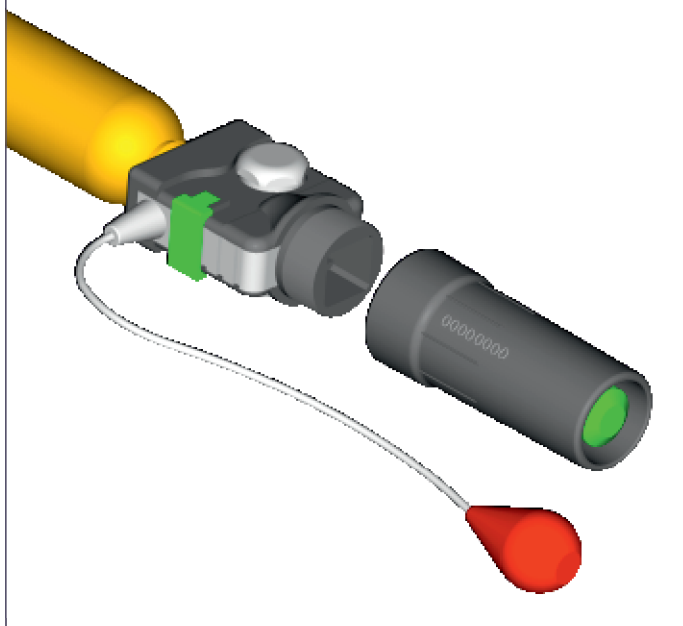

Unscrew the Automatic firing capsule from the end of the operating head. This should only be done after the test detailed in Section 6 has been performed in order to test the old unit, or if the operating head has already been fired. Discard and replace with a new automatic firing capsule upon reassembly. The Capsule must be replaced if it expires before the date of the next annual service. On the Junior version the anti-tamper devices must be removed before unscrewing the cylinder and capsule.

Fig. 3.4.2

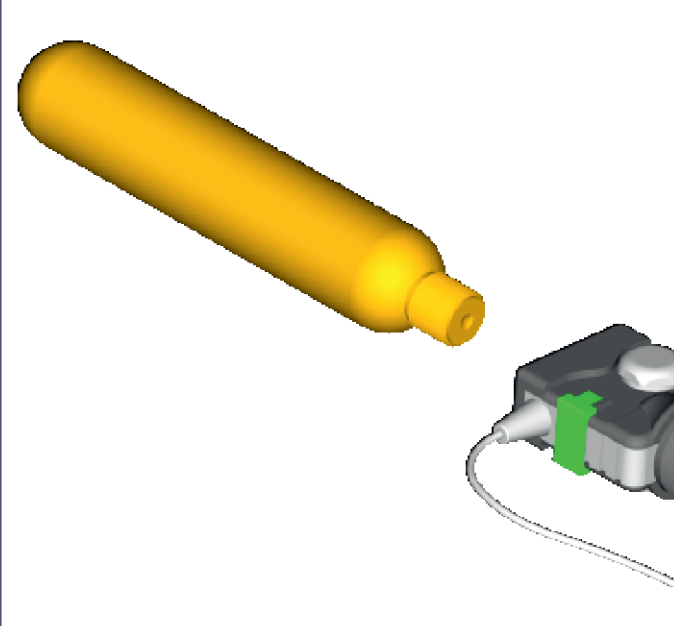

Unscrew the 33 gram cylinder (23 gram for Junior versions) from the automatic operating head. Once the cylinder has been removed inspect the cylinder O-Ring seal. Check the seal is in place and that it is in a good condition. Take the cylinder and check to see if the cylinder has been used. This should be performed by check weighing. If under the minimum weight as displayed on the cylinder body, discard in a safe manner.

Fig. 3.4.3

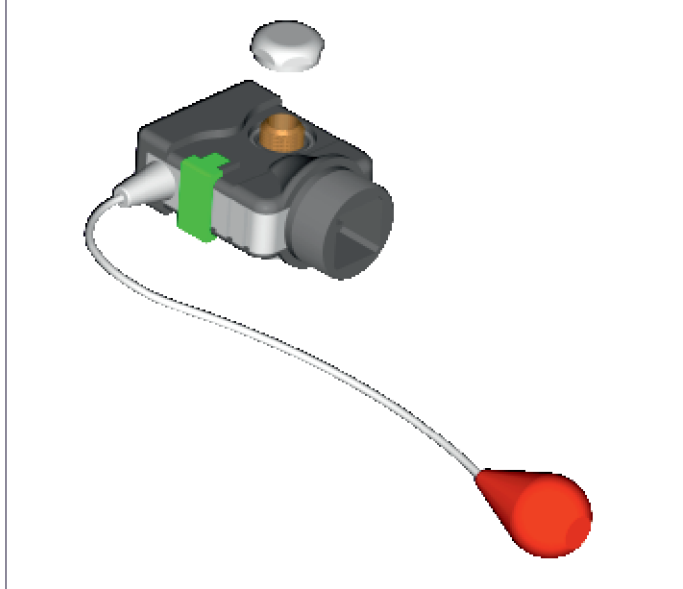

Unscrew the retaining nut from the top of the operating head. Check for corrosion and discard if corroded. Inspect the top sealing O-ring. This must be replaced with a new part if damaged.

Fig. 3.4.4

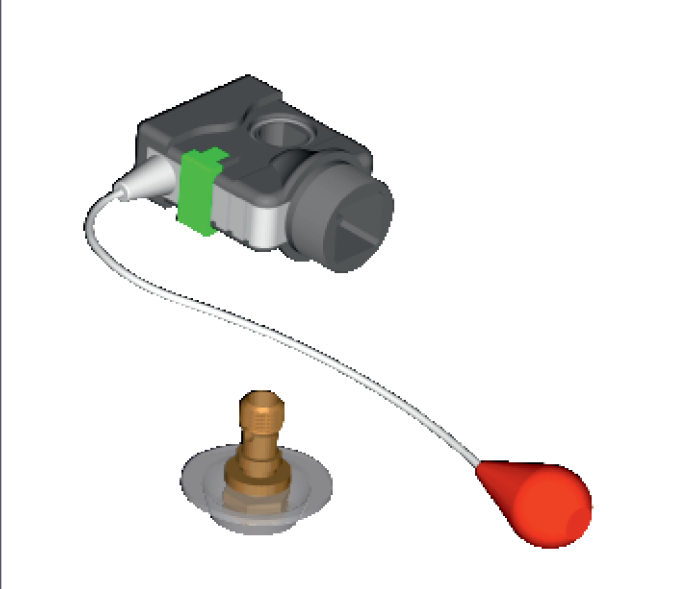

Remove the operating head from the manifold which is welded to the inflation chamber fabric. Inspect the bottom sealing O-ring. This must be replaced with a new part if damaged.

3.5 Manifold Inspection

Replacing Automatic Heads - manifold types to be considered

When replacing automatic operating heads it is important to note that the Mk. 5 operating heads must not be fitted to the old design of manifold (FIGURE 1). FIGURE 2 shows the gas flange fitted on jackets since 1993 and which is suitable for both the Crewsaver and the United Moulders Mk. 5 heads.

If fitted with the old design manifold and a new auto head is needed then the jacket must be returned to Crewsaver for a new inflation chamber to be fitted or, depending on the general condition of the cover, the jacket must be declared as Beyond Economic Repair. All lifejackets with the old design manifold will be at least 20 years old.

The reason for this is that the gas entry holes in the head and manifold no longer line up exactly and so the gas entry is restricted causing potentially slow inflation or icing especially in cold conditions. The undercut on the current design provides the additional clearance needed.

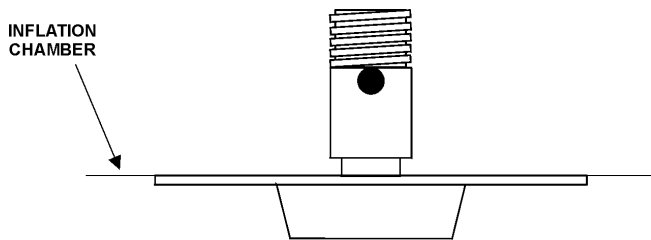

FIGURE 1

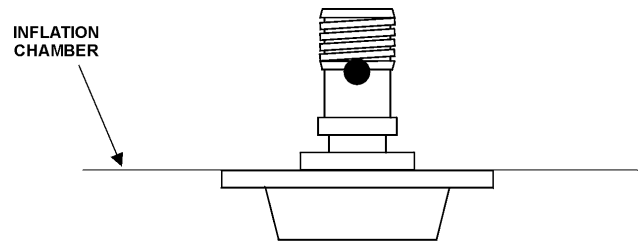
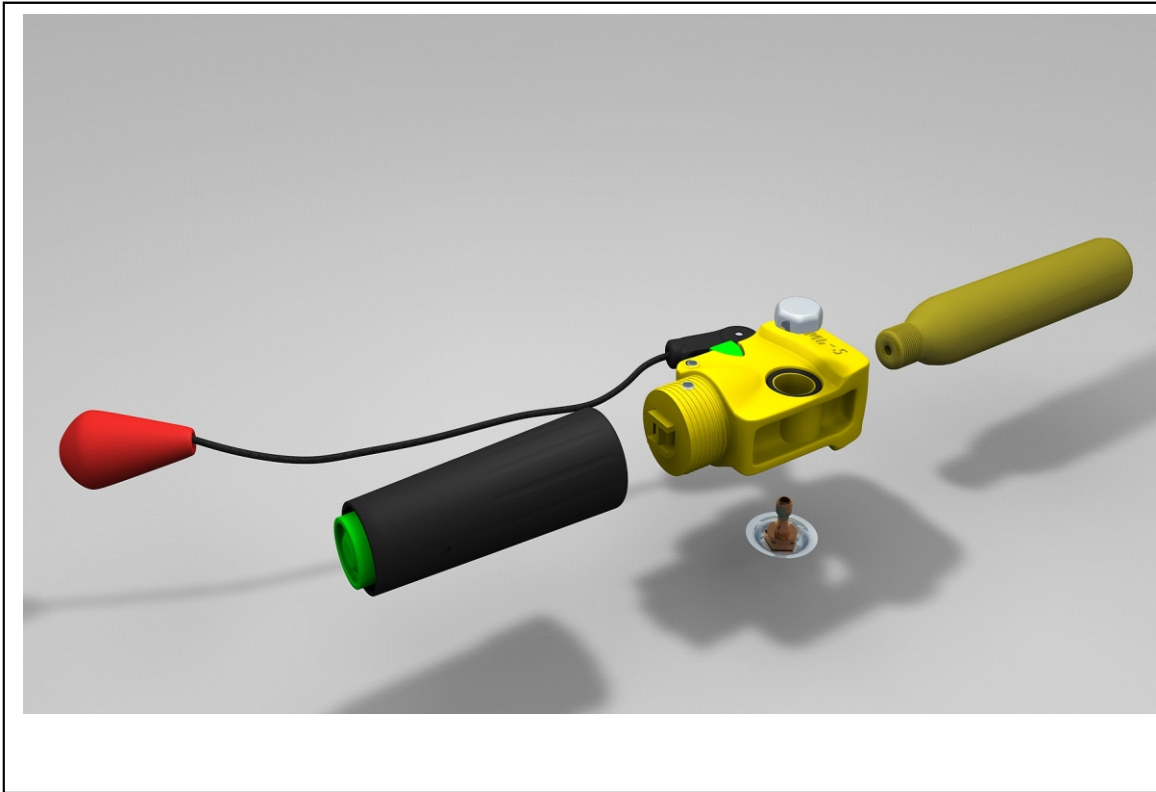

FIGURE 2

Fig 3.6 United Moulders Mk3 Operating Head



JACKETS FITTED WITH THE Mk3 OPERATING HEAD AS ILLUSTRATED ABOVE SHOULD BE RETURNED TO CREWSAVER WHO WILL DETERMINE WHETHER A REPLACEMENT Mk5 OPERATING HEAD CAN BE FITTED.

Fig 3.7 United Moulders Mk5 Operating Head

Starting in June 2010, Crewfit 150 lifejackets with Standard Auto heads will be fitted with the United Moulders Mk5 Auto Head and Mk5i Capsule illustrated above. The serial numbers of these jackets will be prefixed with the letter 'L'. Should it be necessary to change the head or the capsule of these jackets they must be replaced with the new items as shown above.

Supplies of the Crewsaver Mk5 Head and Capsule will continue to be available for fitting onto older lifejackets.

The servicing procedures for the two heads are the same with the following exceptions:

1. The top and bottom sealing 'O' rings are the same for both heads but the cylinder 'O' ring seal on the Crewsaver Mk5 head is replaced by a cutter 'O' ring on the UM Mk5 head.
2. The green retaining clips are not interchangeable.
3. It is particularly important to note that the two different Automatic Capsules are NOT interchangeable.

Fig 3.8 Hammar Operating Head

Fig. 3.7.1

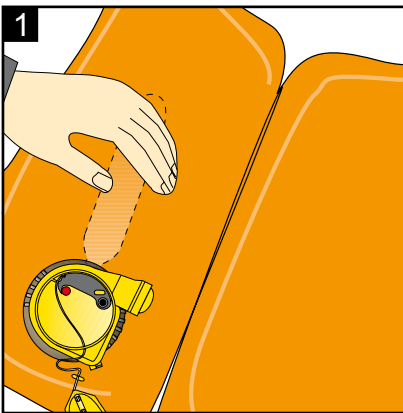

1.
Place the lifejacket on a smooth, flat surface and wipe off any water. Hold the gas cylinder through the fabric, using one hand.

Fig. 3.7.2

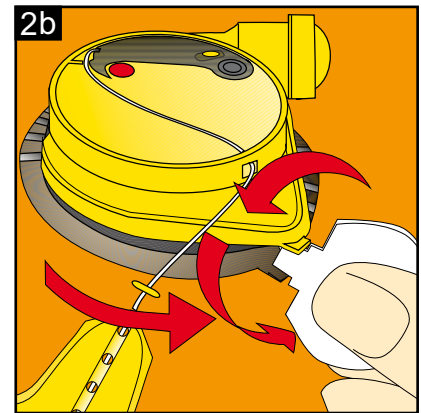
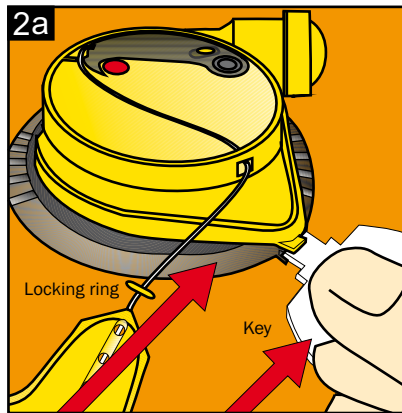

2.
Insert metal key as shown in 2a and turn the key counter-clockwise (2b) between black locking ring and labelled yellow cap. The black locking ring will now turn counter-clockwise.

Fig. 3.7.3

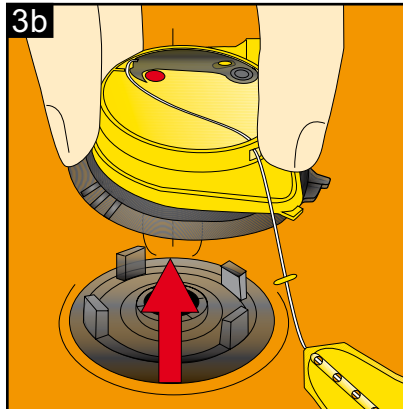
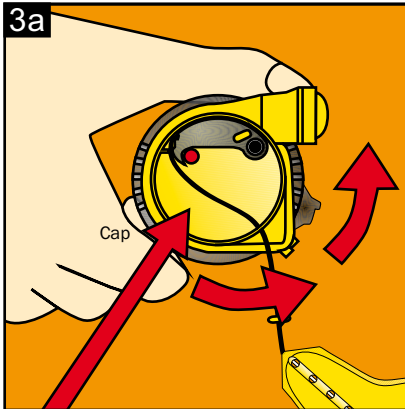

3.
Now turn black locking ring counter-clockwise (3a) and lift cap (3b). (cap = yellow inflator operating head) Dispose of used cap.

Fig. 3.7.4

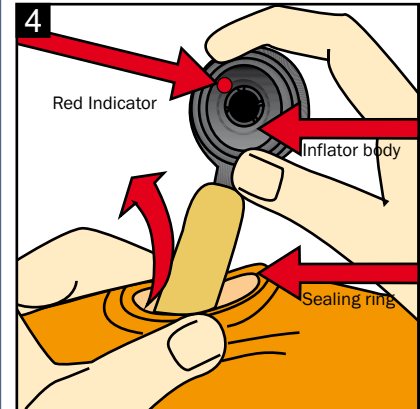

4.
Squeeze sealing ring to elongate and remove the inflator body through the sealing ring. Dispose of used inflator body in an environmentally approved manner.

Please Note: The operating head may not match the images above, but the processes are always the same.

4.1 Cleaning Lifejackets

- 4.1.1 The current standard cover of the Crewfit 150 is made from a 300d polyester fabric with a polyurethane coating that can be cleaned with care. In the event that contamination is such that the materials are inherently damaged refer to section 7.
- 4.1.2 For all types of cover, mud can be removed with clean water and the zip (if fitted) can be cleaned with a stiff (not wire) brush when dry.
 - 4.1.2.1 Contaminants such as oil or diesel fuel may be sponged off immediately with clean water and allowed to dry naturally.
 - 4.1.2.2 Mud can be removed with a stiff (not wire) brush when dry.
 - 4.1.2.3 Covers may be hand washed in good quality mild detergent in cool water (40°C). Rinse well, air drip dry.
- 4.1.3 Sponge the inflation chamber with PURE SOAP SOLUTION ONLY. Rinse in clean water immediately, inflate and air dry.

WARNING: Do not use proprietary cleaning fluids, thinners, spirits or similar substances.

5.1 Outer Cover Inspection

- 5.1.1 Visually inspect the cover material for wear, abrasion, pulled threads, contamination, cuts and holes.
- 5.1.2 If necessary the cover may be washed. Refer to Section 4.
- 5.1.3 Effect repairs if necessary and re-inspect for quality of repaired cover. Refer to Section 7.
- 5.1.4 If it is considered that the cover is beyond economic repair the customer shall be advised and offered a replacement lifejacket.

NOTE: Due to the construction of this lifejacket no individual cover is available for replacement, therefore the lifejacket as a whole must be replaced.

5.2 Inflation Chamber Inspection

- 5.2.1 Visually inspect the inflation chamber material for wear, pulled threads, contamination or signs of mistreatment .
- 5.2.2 Visually inspect all welds. See also Section 5.10 for extra checks on jackets manufactured before 1996.
- 5.2.3 Visually inspect all webbings in accordance with Section 5.6
- 5.2.4 Visually inspect the whistle and its attachment to the lifejacket for mistreatment, defects, and fraying of the cord and its attachment.
- 5.2.5 Test Lifejacket in accordance with Section 6.

5.3 Gas Cylinders

- 5.3.1 Visually examine:
 - 5.3.1.1. For Corrosion (All cylinders corroded with red rust or with visible pitting must be replaced).
 - 5.3.1.2. Pierced or damaged piercing disc.
 - 5.3.1.3. That the cylinder has the correct gas charge - 33 grams CO₂ (23 grams CO₂ Junior versions)
- 5.3.2 Check Min Weight of Cylinder against that marked on the barrel. If the lifejacket is fitted with a Hammar Inflation system (either A1 or MA1) the cylinder will be glued into the Hammar backplate. Do NOT attempt to unscrew the cylinder from the backplate. Instead add 22 grams to the minimum weight shown on the cylinder.

Fig. 5.3

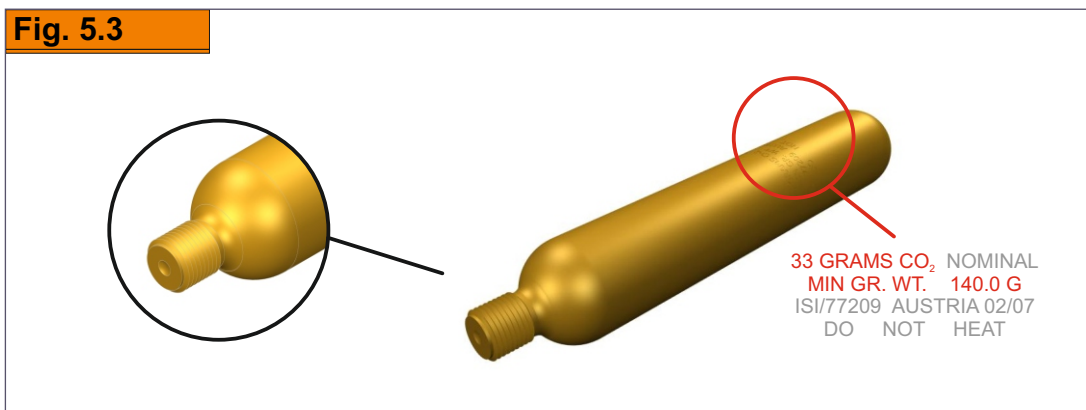

Remedial Action: If any of the above conditions are found to be incorrect the cylinder shall be replaced. See Section 9.

5.4 Mouth Inflation Valve

- 5.4.1 Visually inspect for damage.
- 5.4.2 Test in accordance with Section 6.

Remedial Action: These items are not repairable. Refer to Section 9 for replacement part.

5.5 Inflation System

- 5.5.1 Visually inspect the Operation of the Manual or Automatic Mechanism for:
 - 5.5.1.1 Operation of the Manual override lever. This shall move easily and freely.
 - 5.5.1.2 Operation of the firing pin cam action. Similarly this shall be a smooth action when the lever is operated.
 - 5.5.1.3 Firing Pin centre discharge hole clear.
 - 5.5.1.4 Activation cord for frays and damage.
 - 5.5.1.5 Moulded body for cracks and damage. Special attention to be given to the areas around the operating lever/body connection pin.
 - 5.5.1.6 Check the Automatic plunger (Automatic Head Only) at the base of the unit when depressed moves the firing pin and that the plunger and the firing pin return to their original positions when released.

Remedial Action: In the event that the Operating Mechanism fails any of the above inspection procedures, the complete unit shall be replaced. No Repairs are allowed. Refer to Section 9 for the part number of the relevant replacement part.

- 5.5.2 Visually inspect the Operation of the Automatic Capsule on the automatic Operating Head:
 - 5.5.2.1 Check plug is in place at the base of the capsule.
 - 5.5.2.2 New Capsules are to be fitted where the expiry date is before the next annual service of the lifejacket. E.g. capsules marked 'Replace by 2010' expire at the end of 2010.
 - 5.5.2.2.1 If the capsule is to be replaced – Re-fit the old capsule and carry out operational tests. Refer to section 6.
- 5.5.3 For Hammar Manual or hydrostatic remove and inspect. For the Hydrostatically operated head ensure that indicator is green, and that the handle has not been pulled, or displaced. See Fig 5.5 below.

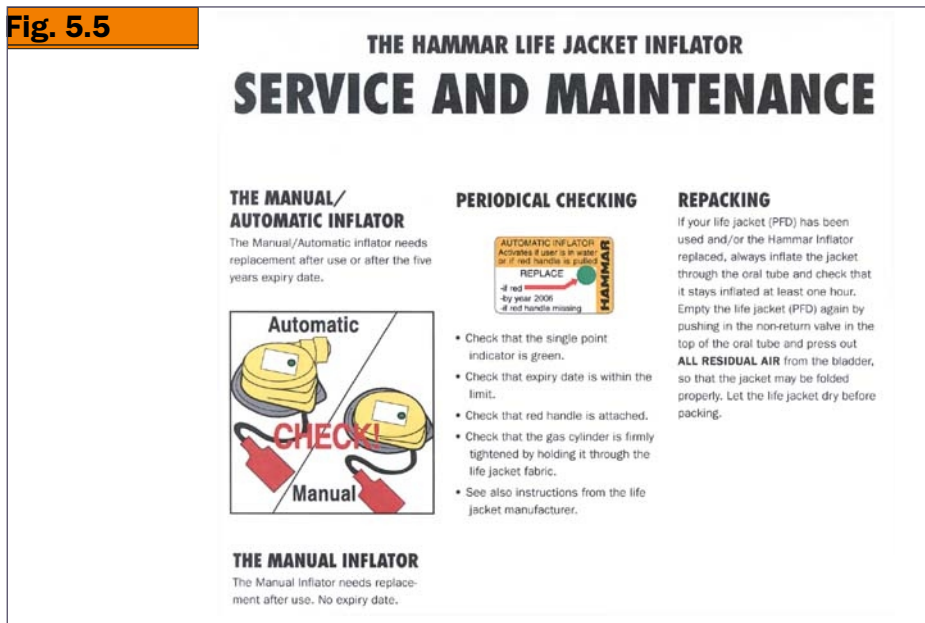

Remedial Action: In the event that the Operating Mechanism fails any of the above inspection procedures, the complete Unit shall be replaced. No repairs are allowed. Refer to Section 9 for the part number of replacement parts.

5.6 Webbings

- 5.6.1 Visually inspect for damage:
 - 5.6.1.1. Fraying
 - 5.6.1.2. Pulled Threads
 - 5.6.1.3. Broken Stitches

Remedial Action: Effect repairs in accordance with the Repair Procedures within the limits defined in Section 7.

5.7 Buckles

- 5.7.1 Visually inspect all buckles used on the webbings for signs of damage or corrosion.

Remedial Action: No repairs are allowed. In the case of damage being found, return the Lifejacket to Crewsaver.

5.8 Labelling/Markings

- 5.8.1. Check all Markings and Labelling are clear and legible.

Remedial Action: No repairs are allowed. In the case of damage being found, return the Lifejacket to Crewsaver.

5.9 Lights (if fitted)

- 5.9.1 There are many lights available and all have a means of testing the light. Each light will have an expiry date printed on the light. Below is the example of an L6 light (with manual operation) and a description on testing.

- 5.9.1.2 Inspect the light for any signs of damage. If there are chips or cracks the light must be replaced.
- 5.9.1.3 Check that the light is securely attached to the lifejacket

- 5.9.2 To test this unit to ensure the light is working correctly:

- 5.9.2.1 Press the manual activation point (B) Figure 5.2. This will activate the light which should start to blink
- 5.9.2.2 Return it to its original position by pushing the activation lanyard, Figure 5.3. This will turn the light off.

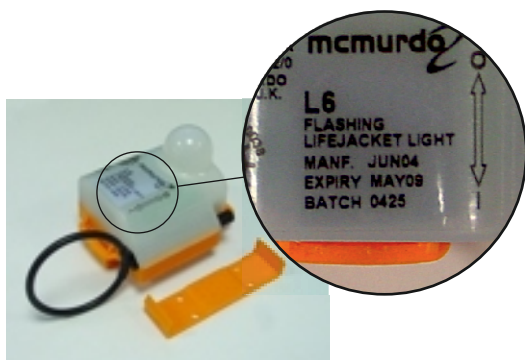

Figure 5.1

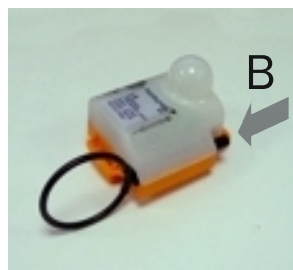

Figure 5.2



Figure 5.3

- 5.9.3 Check the expiry date (Fig. 1) and replace light if necessary.

- 5.9.4 These lights are not repairable; if the light fails inspection it must be replaced with a CSL light.

5.9.5 More recent jackets may be fitted with the Crewsaver CSL Water Activated Light.

Visually inspect the light for signs of damage to:

5.9.5.1. The switch.

5.9.5.2. the cable.

5.9.5.3. the lens and its mounting or housing.

5.9.6 Check expiry date on battery. The expiry date must exceed the date of the next annual service. If the light has expired or expires before the next service then it must be replaced. (See Section 9).

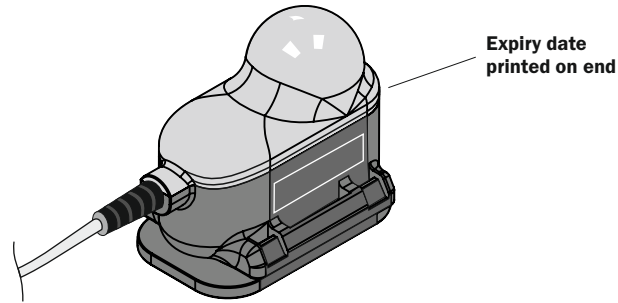

5.9.7 Ensure that the switch is in the Auto-on position.

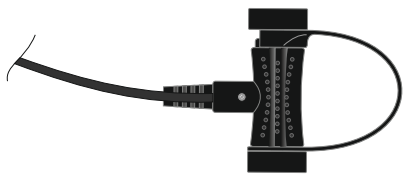

Water activated switch in Auto-on position (Earlier models)

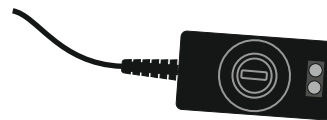

Water activated switch in Auto-on position (Later models)

5.9.8 Test the assembly as detailed in Section 6

5.10 Gas Flange and Inflation Tube Inspection

Checking and monitoring the attachment of the Gas Flange and Oral Inflation Tube

Degradation of the attachment weld of the Gas Flange and the Oral Inflation Tube can occur on older jackets depending on the climatic conditions experienced by the jacket. Newer jackets are unaffected.

1. To establish if the jacket needs to have the attachments checked establish the age of the lifejacket from the service record or from the batch and date code on the inflator. Look at the bottom right hand corner. The final 2 digits of the 6 figure code give the year of manufacture, e.g. 646193 was manufactured in 1993.

Jackets manufactured in 1995 or earlier need to be considered.

2. Where the bases of the Gas Flange and Oral Inflation Tube show as a black ring, these must be measured. All Oral Inflation Tubes will be like this but some later models of lifejacket could be fitted with a Gas Flange that has a clear base. These Gas Flanges need not be checked.
3. To measure the width of the weld on the Gas Flanges first remove the automatic head. If the jacket is a Seafire Solas the rear Gas Flange must then be pulled through the neck opening to make it accessible. Measure the width of the black annulus at its narrowest point as per the diagram below:

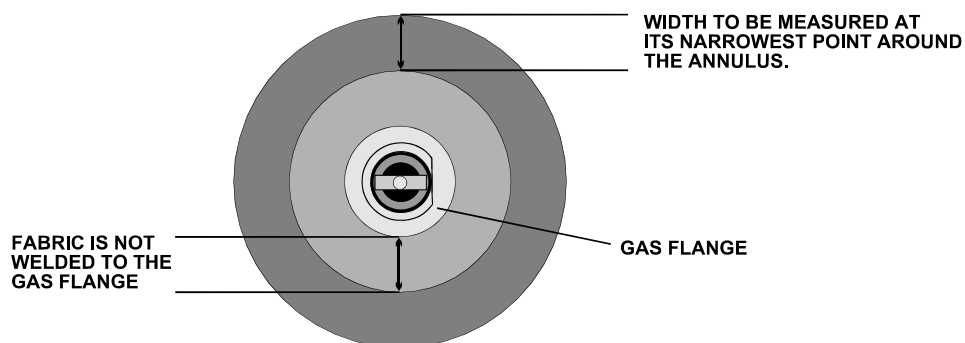

4. When measuring the width of the welds on the Oral Inflation Tubes again pull the rear Tube through the neck opening if the jacket is a Seafire Solas. Measure the width of the weld noting that the weld normally starts from the edge of the fabric. As a final test grasp the Inflation Tube and gently try to rotate it.
5. The measurements taken must be 3.00mm. or greater. If a measurement is less than 3.00mm the jacket must be returned to Crewsaver for the inflator to be replaced.

6.1 Inflation Chamber

6.1.1. Air Holding Test.

6.1.1.1 Connect through a suitable Tee piece and adaptor, the oral tube with the oral valve in the open position, to a graduated water manometer (or a similar digital device for measuring back pressure).

Note: Hammar inflators must be tested with the Hammar operating head fitted to the inflation chamber.

6.1.1.2 Slowly inflate the lifejacket from a regulated supply until manometer reads 200mbar

Warning: Regulated supply pressure must not exceed 20psi.

6.1.1.3 Close off the air supply and leave for 10 minutes to ensure pressure is stable.

6.1.1.4 Check and record the pressure and temperature reading on the Service Record Sheet.

6.1.1.5 Leave for 30 minutes.

6.1.1.6 Check and record the pressure and temperature reading on the Service Record Sheet.

The maximum difference in the two pressure readings (pressure drop) allowed is 10%. The temperature differential shall be within plus or minus 3 degrees of the original reading. For each degree Centigrade rise in temperature subtract 2.5 mbar. For each degree Centigrade drop in temperature add 2.5 mbar to the readings to obtain the actual pressure variation. Should the temperature variation be outside 3 degrees either way then the test shall be repeated.

PSI	mH ₂ O	mHg	mmH ₂ O	mmHg	kg/cm ²	bar	mbar	Pa	kPa
1.0	27.71	2.036	703.1	51.75	0.0703	0.0689	68.95	6895	6.895
1.1	30.48	2.240	773.4	56.93	0.0773	0.0758	75.85	7585	7.585
1.2	33.25	2.443	843.7	62.10	0.0844	0.0827	82.74	8274	8.274
1.3	36.02	2.647	914.0	67.28	0.0914	0.0896	89.64	8964	8.964
1.4	38.79	2.850	984.3	72.45	0.0984	0.0965	96.53	9653	9.653
1.5	41.57	3.054	1054.7	77.63	0.1055	0.1034	103.43	10343	10.34
1.6	44.34	3.258	1125.0	82.80	0.1125	0.1102	110.32	11032	11.03
1.7	47.11	3.461	1195.3	87.98	0.1195	0.1171	117.22	11722	11.72
1.8	49.88	3.665	1265.6	93.15	0.1265	0.1240	124.11	12411	12.41
1.9	52.65	3.868	1335.9	98.33	0.1336	0.1309	131.01	13101	13.10
2.0	55.42	4.072	1406.2	103.50	0.1406	0.1378	137.90	13790	13.79
2.1	58.19	4.276	1476.5	108.68	0.1476	0.1447	144.80	14480	14.48
2.2	60.96	4.479	1546.8	113.85	0.1547	0.1516	151.69	15169	15.17
2.3	63.73	4.683	1617.1	119.03	0.1617	0.1585	158.59	15859	15.86
2.4	66.50	4.886	1687.4	124.20	0.1687	0.1654	165.48	16548	16.55
2.5	69.28	5.090	1757.8	129.38	0.1758	0.1723	172.38	17238	17.24
2.6	72.05	5.294	1828.1	134.55	0.1828	0.1791	179.27	17927	17.93
2.7	74.82	5.497	1898.4	139.73	0.1898	0.1860	186.17	18617	18.62
2.8	77.59	5.701	1968.7	144.90	0.1968	0.1929	193.06	19306	19.31
2.9	80.36	5.904	2039.0	150.08	0.2039	0.1998	199.96	19996	20.00
3.0	83.13	6.108	2109.3	155.25	0.2109	0.2067	206.85	20685	20.69
3.1	85.90	6.312	2179.6	160.43	0.2179	0.2136	213.75	21375	21.37
3.2	88.67	6.515	2249.9	165.60	0.2250	0.2205	220.64	22064	22.06
3.3	91.44	6.719	2320.2	170.78	0.2320	0.2274	227.54	22754	22.75
3.4	94.21	6.922	2390.5	175.95	0.2390	0.2343	234.43	23443	23.44
3.5	96.99	7.126	2460.9	181.13	0.2461	0.2412	241.33	24133	24.13
3.6	99.76	7.330	2531.2	186.30	0.2531	0.2480	248.22	24822	24.82
3.7	102.53	7.533	2601.5	191.48	0.2601	0.2549	255.12	25512	25.51
3.8	105.30	7.737	2671.8	196.65	0.2671	0.2618	262.01	26201	26.20
3.9	108.07	7.940	2742.1	201.83	0.2742	0.2687	268.91	26891	26.89
4.0	110.84	8.144	2812.4	207.00	0.2812	0.2756	275.80	27580	27.58
4.1	113.61	8.348	2882.7	212.18	0.2882	0.2825	282.70	28270	28.27
4.2	116.38	8.551	2953.0	217.35	0.2953	0.2894	289.59	28959	28.96
4.3	119.15	8.755	3023.3	222.53	0.3023	0.2963	296.49	29649	29.65
4.4	121.92	8.958	3093.6	227.70	0.3093	0.3032	303.38	30338	30.34
4.5	124.70	9.162	3164.0	232.88	0.3164	0.3101	310.28	31028	31.03
4.6	127.47	9.366	3234.3	238.05	0.3234	0.3169	317.17	31717	31.72
4.7	130.24	9.569	3304.6	243.23	0.3304	0.3238	324.07	32407	32.41
4.8	133.01	9.773	3374.9	248.40	0.3374	0.3307	330.96	33096	33.10
4.9	135.78	9.976	3445.2	253.58	0.3445	0.3376	337.86	33786	33.79
5.0	138.55	10.180	3515.5	258.75	0.3515	0.3445	344.75	34475	34.48
5.1	141.32	10.384	3585.8	263.93	0.3585	0.3514	351.65	35165	35.17
5.2	144.09	10.587	3656.1	269.10	0.3656	0.3583	358.54	35854	35.86
5.3	146.86	10.791	3726.4	274.28	0.3726	0.3652	365.44	36544	36.55
5.4	149.63	10.994	3796.7	279.45	0.3796	0.3721	372.33	37233	37.24
5.5	152.41	11.198	3867.1	284.63	0.3867	0.3790	379.23	37923	37.93
5.6	155.18	11.402	3937.4	289.80	0.3937	0.3858	386.12	38612	38.62
5.7	157.95	11.605	4007.7	294.98	0.4007	0.3927	393.02	39302	39.31
5.8	160.72	11.809	4078.0	300.15	0.4077	0.3996	399.91	39991	39.99
5.9	163.49	12.012	4148.3	305.33	0.4148	0.4065	406.81	40681	40.68
6.0	166.26	12.216	4218.6	310.50	0.4218	0.4134	413.70	41370	41.37

- 6.1.1.7. If Lifejacket fails the Air holding test inspect as follows.
- 6.1.1.7.1 With the lifejacket inflated carefully brush or spray the surface with a weak solution of soap and water or alternatively lower the lifejacket into a tank of water to observe for bubbles.
- 6.1.1.7.2 Identify and mark the source of leakage. Wash off in clean water and allow to dry naturally in air.
- 6.1.1.7.2.1 Special Attention to be given to:
- a) Manifold Schrader Core
 - b) Oral Tube/ Top-up Valve
- 6.1.2 If the test is satisfactory deflate the Lifejacket in preparation for re-assembly. Refer to Section 8.
- 6.1.2.1. Insert the inverted oral valve dust cap into the top of the oral valve and expel the air. Lifejackets may also be deflated using the Crewsaver Venturi Vacuum System. For the part number, refer to Section 9.
- 6.1.3 Effect repairs in accordance with the Repair Procedures within the limits defined in Section 7.
- 6.1.4 Subsequent to remedial action being taken (see Section 7), retest the lifejacket in accordance with Section 6.

6.2 Valves

- 6.2.1. Oral Valve.
- 6.2.1.1. When removing the test adapter from each oral valve check that the oral valve reseats. If in doubt this may be checked by placing the valve underwater.
- 6.2.2 Schrader Valve.
- 6.2.2.1 Should a leak be found in the Schrader valve the faulty core must be removed and a new valve inserted using the Torque Screwdriver from the tool kit.

6.3 Inflation Mechanisms

- 6.3.1 Operational Test for Halkey Roberts Manual Operation.
- 6.3.1.1 Remove the operating mechanism from the lifejacket. With the cylinder also removed, pull the lever on the side of the operating head, and check that the firing pin is visibly moving inside the open end.
- 6.3.1.2 If the lever does not move, or the firing pin is not clearly moving, the operating head must be replaced. Refer to Section 9 for part number.
- 6.3.2 Operational Test for Crewsaver Mk5 Automatic Operating Heads (to be performed when capsules have expired).
- 6.3.2.1 Remove the operating mechanism from the lifejacket and remove the cylinder.
- 6.3.2.2 Assemble the expired capsule onto the body of the operating mechanism.
- 6.3.2.3 Place the complete unit into water and check that the unit operates within 5 seconds.
- 6.3.2.4 If the mechanism fails to pass repeat test replace the complete unit. Refer to Section 9 for part Number of the replacement part.

NOTE: All failures of this test must be reported to Crewsaver. Crewsaver may require the failed units to be returned. Please do not discard.

6.4 Retro Reflective Tape

- 6.4.1 If the retro reflective tape shows any signs of degradation the following tests shall be carried out in accordance with Marine Guidance Note MGN 105 (M+F) Issued by the UK Marine and Coast guard Agency March 1999.
- 6.4.1.1 Place a new piece of the same retro-reflective material to, and on the same plane as, a representative piece of material fitted to the appliance.
- 6.4.1.2 Pour water over both pieces of material.
- 6.4.1.3 Using a powerful torch or "Aldis" lamp held at eye level, compare the performance of the two pieces of material from a distance of 10 Metres.
- 6.4.1.4 If a noticeable deterioration in performance is observed then the retro-reflective material on the appliance should be replaced.
- 6.4.1.5 Dry off the lifejacket before repacking.

6.5 Lights and Batteries

6.5.1. Testing Procedure for lights fitted to lifejackets.

The following sea lights have been fitted to Crewsaver Commercial and Leisure lifejackets. All light units used have a detailed expiry date, after which the light should be carefully disposed of.

6.5.1.1 Daniamant L6

The Daniamant L6 can be tested using the switch located on the right side (as looked at). If necessary, replace with a Crewsaver CSL Light.

6.5.1.2 Crewsaver CSL Water Activated Light.

Test the light by immersing the sensor in water. The light must flash, remove the light from the water and dry it. The light must stop flashing. If the light does not flash the unit has expired and must be replaced.

7.1 Outer Cover

7.1.1 No repairs are permitted to the outer cover.

7.2 Inflation Chamber

7.2.1 No repairs are permitted to the inflator fabric or its assembly, due to the construction of this lifejacket.

7.2.2 Components attached to the inflator may be repaired in line with the limits defined below.

7.3 Gas Cylinders

7.3.1 No repairs permitted. For the Part No. of the replacement part refer to Section 9

7.3.2 Please ensure cylinders are disposed of in accordance with local regulations.
Treat empty cylinders as steel for recycling purposes.

7.4 Valves

7.4.1 No repairs permitted. For the Part No. of the replacement parts refer to Section 9

7.4.2 Replacement of the Oral valve may be achieved by.

7.4.2.1 Carefully removing the defective unit by applying force, with a blunt instrument, behind the oral valve Squeezing the tube and gently pushing the valve out.

7.4.2.2 Push the replacement valve into the oral tube.

Fig. 7.4

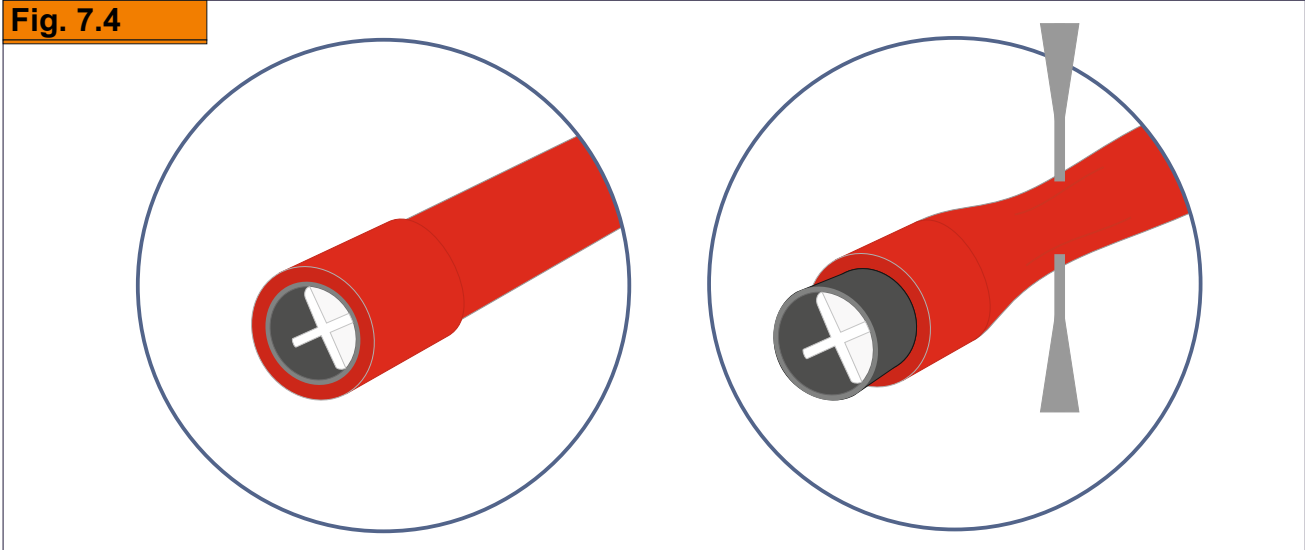

7.5 Inflation System

7.5.1 A Schrader core is located inside the Valve Stem.

7.5.1.1 Remove and replace using the calibrated torque driver for Schaefer valves set to 0.32 - 0.36 Nm. Refer to Section 9 for the Part No. of the replacement part.

WARNING: Only fit replacement Schrader valves obtained from Crewsaver.

7.5.2 Operating Mechanism.

7.5.2.1 No repairs permissible. Replace the complete unit.
Refer to Section 9 for the Part No. of the replacement part.

7.6 Webbing

7.6.1 No cuts are allowed in the webbing of any of these components. No repairs are permitted on Harness Lifejackets. Worn, broken or cracked stitches are to be over sewn by 25mm in each direction past the extent of the fault, use only approved thread. (Refer to Crewsaver). In the case of the Crutch Strap replace damaged unit. Refer to Section 9 for Part No. of the replacement part.

NOTE: Only pre approved stitching repairs are allowed. All persons carrying out repairs must be authorised by Crewsaver.

7.7 Buckles

7.7.1. These components are not repairable or replaceable. Lifejackets with damaged buckles should be returned to Crewsaver.

7.8 Repair Parameters - Stitching

All repairs to stitching must be carried out by a company deemed fit to perform the repair by Crewsaver prior to the work commencing.

- a.) Stitching repairs should be performed when the visible inspection as detailed in section 5, Para 5.1 identifies broken or pulled stitches. The following repairs maybe made:
- ai. Repairs to broken stitches should be over sewn following the same line of stitching , ensuring that the stitching continues for a minimum of 20mm past the repair section, each end must be back tacked twice.
 - aii. Repairs to pull threads should be repaired by first trimming the lose ends and then repeating the process as detailed above.
 - aiii. Any repairs carried out must be made using the correct thread available from Crewsaver. No other types of thread are to be used.
 - aiv. No stitching repairs are to be made to the inflation chamber, or parts stitched to it.
 - av. **No stitching repairs are to be made on Harness Lifejackets.**

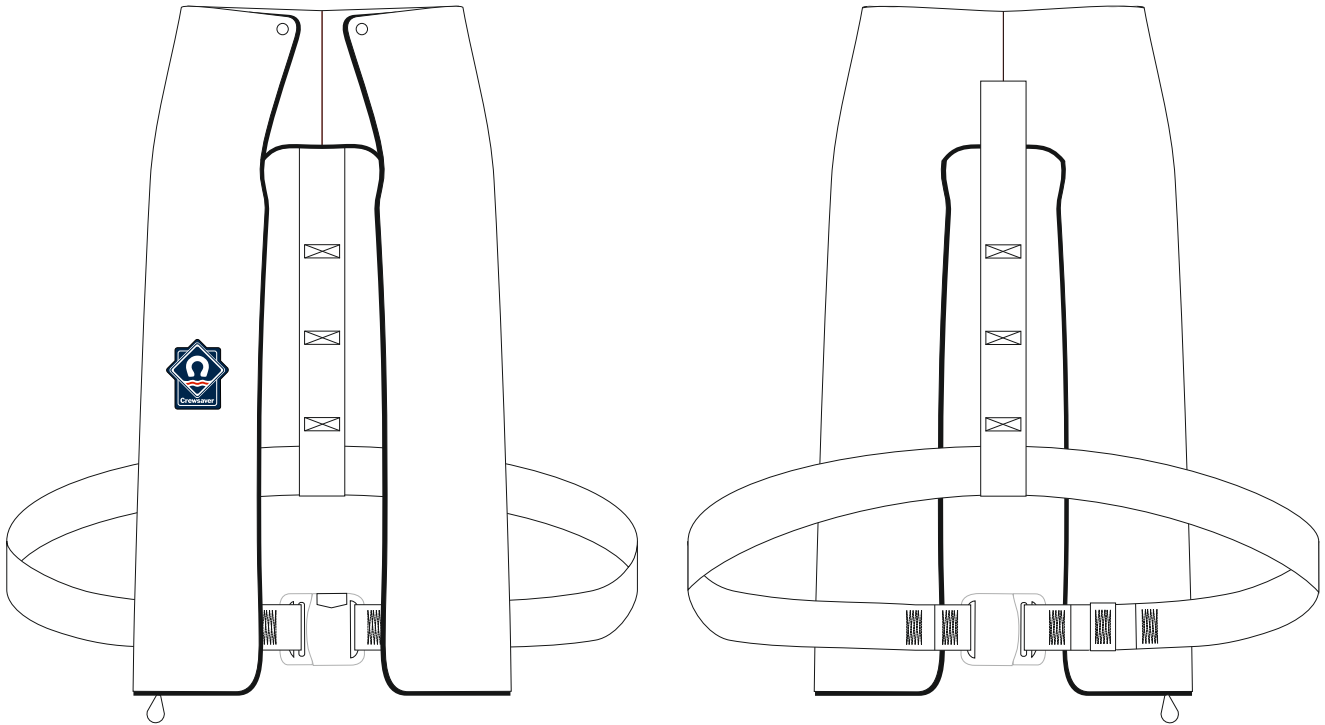

8.1 Assembly

- 8.1.1 Ensure the whistle is positioned and tied in correctly.
- 8.1.2 Expel the air from the chamber by inverting the dust cap on the oral tube. Lifejackets may also be deflated using the Crewsaver Venturi Vacuum System. For the part number, refer to Section 9.
- 8.1.3 Assemble the Operating Mechanism to the inflator.
 - 8.1.3.1 For Halkey Roberts Manual Operating Mechanisms. See Fig 8.2
 - 8.1.3.1.1 A new firing retaining pin/ clip, upper and lower manifold gaskets must be fitted. Refer to Section 9 for Part Numbers.
 - 8.1.3.1.2 Fit new lower gasket.
 - 8.1.3.1.3 Locate operating head onto manifold.
 - 8.1.3.1.4 Fit new top gasket.
 - 8.1.3.1.5 Tighten the retaining nut onto the body using the Calibrated torque driver provided in the Crewsaver servicing tools. Note: Retaining nut must be tightened to between 2.5 and 2.7 Nm.
 - 8.1.3.1.6 Firmly screw the cylinder adaptor by hand into the head
 - 8.1.3.1.7 Connect the cylinder adaptor to the pressure test unit
 - 8.1.3.1.8 Pressurise the head to between 25 and 30 psi and release the control to its vertical position.
 - 8.1.3.1.9 There may be a slight decrease in pressure over the first 2 seconds as the unit stabilises. Leave for 10 seconds and check for any further decrease in pressure shown on the gauge
 - 8.1.3.1.10 Release the pressure by turning the control to deflate.
 - 8.1.3.1.11 If there had been any decrease in pressure remove the cylinder adaptor, remove the operating head and check the following.
 - a. Thick and thin washer either side of the head.
 - b. Damage to the D post seating.
 - c. Cross thread chrome nut
 - d. The cylinder seating washer.
 - e. The schrader or pang valve in the 'D' post.
 - f. The operating head
 - 8.1.3.1.12 Fit the gas cylinder to the firing mechanism by hand then check using the torque wrench (4Nm) and head adaptor from the tool kit. The operating head is gripped in one hand and the cylinder tightened using the torque wrench with the cylinder tightening tool held in the other hand.

Warning: Care must be taken not to 'cross thread' the connection.

- 8.1.3.2 For United Moulders Mk5 Automatic Operating Mechanisms. See Fig 8.3
 - 8.1.3.2.1 A new retaining clip must be fitted. Refer to Section 9 for replacement parts.
 - 8.1.3.2.2 Fit the new automatic firing capsule to the operating head, screw hand tight.
 - 8.1.3.2.3 Locate Operating head onto the Manifold.
 - 8.1.3.2.4 Tighten the retaining nut onto the body using the Calibrated torque driver provided in the Crewsaver servicing tools. Note: Retaining nut must be tightened to between 2.5 and 2.7 Nm.
 - 8.1.3.2.5 Firmly screw the cylinder adaptor by hand into the head
 - 8.1.3.1.6 Connect the cylinder adaptor to the pressure test unit
 - 8.1.3.1.6 Pressurise the head to between 25 and 30 psi and release the control to its vertical position.
 - 8.1.3.1.7 There may be a slight decrease in pressure over the first 2 seconds as the unit stabilises. Leave for 10 seconds and check for any further decrease in pressure shown on the gauge
 - 8.1.3.1.8 Release the pressure by turning the control to deflate.
 - 8.1.3.1.9 If there had been any decrease in pressure remove the cylinder adaptor, remove the operating head and check the following.
 - a. Thick and thin washer either side of the head.
 - b. Damage to the D post seating.
 - c. Cross thread chrome nut
 - d. The cylinder seating washer.
 - e. The schrader or pang valve in the 'D' post.
 - f. The operating head

Warning: Care must be taken not to 'cross thread' the connection.

8.1.3.2.10 Fit the gas cylinder to the firing mechanism by hand then check using the torque wrench and head adaptor from the tool kit (4Nm). The operating head is gripped in one hand and the cylinder tightened using the torque wrench with the cylinder tightening tool held in the other hand.

8.1.3.3 For Hammar Hydrostatic and Manual Operating Mechanisms. See Fig 8.4

8.1.3.3.1 If the operating head has been fired, tampered with, does not comply with any of the details in 5.5.3 or the red firing handle is missing; a replacement operating mechanism must be fitted.

8.1.3.3.2 If a new CO₂ cylinder is required a replacement cylinder ALREADY ATTACHED to an inflator body must be purchased from Crewsaver.

8.1.3.3.3 Insert the cylinder and inflator body into the inflation chamber through the sealing ring, ensure that the cylinder is vertically positioned in the inflation chamber.

8.1.3.3.4 Seat the inflator body underneath the sealing ring. Locate the inflation mechanism to the sealing ring and the inflator body, with the red firing handle facing directly down the inflation chamber away from the cylinder. Using the Hammar operating head tightening key, clip the mechanism closed.

Warning: Care must be taken not to 'cross thread' the connection.

8.1.4 To re-pack the lifejacket see Fig 8.5 Fig 8.8

8.1.5 Expel additional excess air, during the packing operation, from within the inflator by again inverting the cap on the oral tube and inserting it into the oral valve. When all excess has been expelled replace the cap.

8.1.6 Mark Service Label on Lifejacket (using an indelible pen) and Service Record Sheet with the date of the service.

8.1.7 Ensure the serial number has been correctly recorded and that it is clearly marked on the Record Sheet.

Warning: The lifejacket folding procedures must be followed accurately to ensure that the lifejacket inflation mechanism operates and the lifejacket deploys correctly. The lifejacket shall not be folded and/or packed using any other method or procedure than that specified.

Fig 8.2 Halkey Roberts Operating Head

Fig. 8.2.1

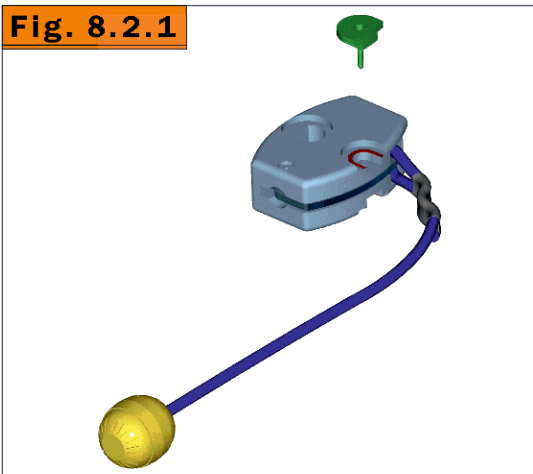

Following the inspection and testing procedures for Halkey Roberts Manual operating heads as detailed in Section 5 and 6. Fit the retaining clip or pin. Both the green retaining u-shaped clip and the green retaining pin, perform the same job, either may be fitted. The clip is fitted by pressing it over the firing arm and in to the recess either side in the centre of the operating head. The clip will click into place, thereby preventing the arm from moving. The pin is fitted by pushing down through the hole in the middle of the recess, and through the hole in the firing arm. The pin must be pushed in from the side that will be facing upwards, when the operating head is fitted on to the stole.

Fig. 8.2.2

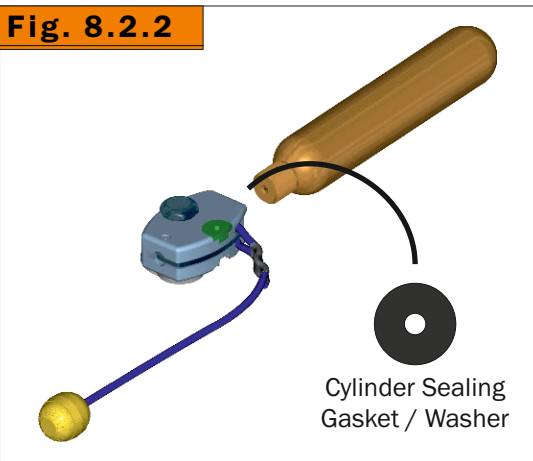

Check that the cylinder sealing gasket in the end of the operating head has been correctly fitted, or replaced if necessary. Ensure that the cylinder has been check weighed before fitting to the lifejacket. Fit the gas cylinder to the firing mechanism using the torque wrench (4Nm) and head adaptor from the tool kit. The cylinder is gripped in one hand and the head tightened using the torque wrench held in the other hand.

Fit the new bottom sealing washer / gasket on to the manifold. The gasket must sit flat on the manifold and lie underneath the bottom collar at the base of the manifold. Before fitting the operating head onto the manifold, check that the Schrader valve is fitted. If fitting a new schrader valve use a calibrated torque driver set to 0.32 - 0.36 Nm. Then place the operating head onto the manifold, so that the cylinder threaded opening is facing the cylinder elastic. (away from the bottom of the inflator).

Fig. 8.2.3

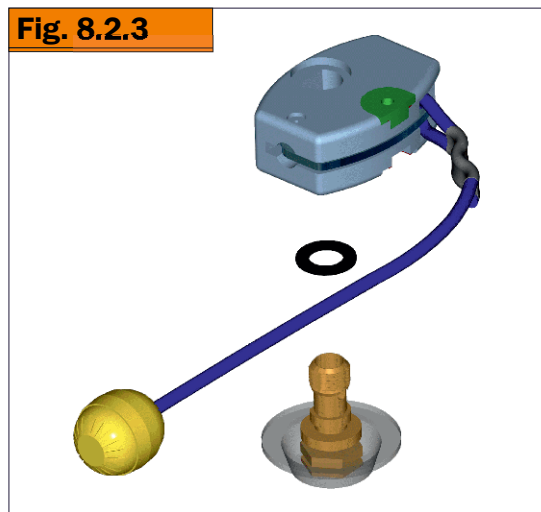

With the operating head fitted to the manifold, place the top gasket into the recess over the protruding end of the manifold. The two gaskets differ in size as shown below:-

Bottom Sealing Gasket / Washer



Top Sealing Gasket / Washer



With the top gasket in place, fit the retaining nut. The retaining nut should be screwed in to place using a torque wrench or driver fitted with a 9/16" socket. The wrench or driver should be set to between 2.5 and 2.7 Nm. This will prevent damage to the operating head and ensure a good seal is maintained.

Fig. 8.2.4

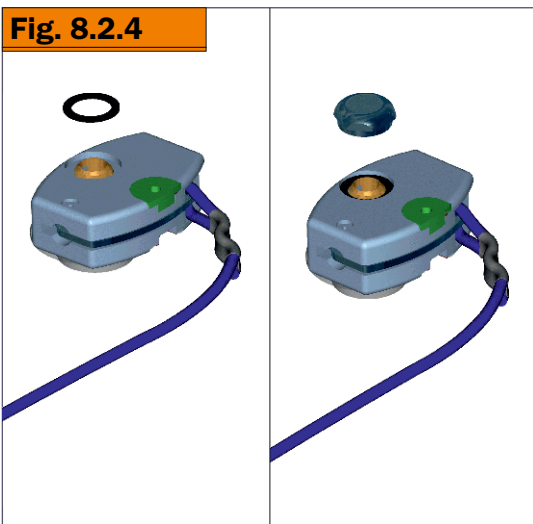

Fig 8.3 Crewsaver Mk5 Operating Head

Check that the cylinder sealing gasket in the end of the operating head has been correctly fitted, or replaced if necessary. Fit the 33 gram CO₂ cylinder. (23 gram for Junior versions) Ensure that the cylinder has been check weighed before fitting to the lifejacket. Fit the gas cylinder to the firing mechanism using the torque wrench (4Nm) and head adaptor from the tool kit. The cylinder is gripped in one hand and the head tightened using the torque wrench held in the other hand. On Junior versions of the Crewfit refit the anti-tamper device over the cylinder.

Fig. 8.3.1

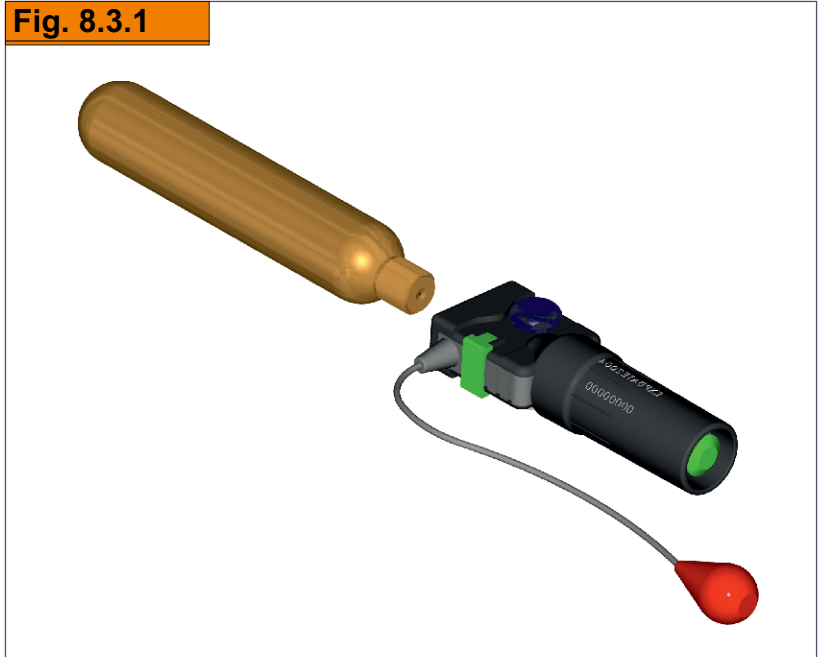

Fig. 8.3.2



Fit the new firing capsule onto the operating head. Capsules fitted on the Crewsaver Mk5 head are navy blue in colour. The capsule should be screwed tight to the end. Make a note of the batch number and manufacture date on to the service record sheet. On Junior versions of the Crewfit refit the anti-tamper device over the capsule.

If the lifejacket is fitted with a United Moulders Mk5 head a M5i firing capsule must be fitted. These are black in colour.

Fig. 8.3.3

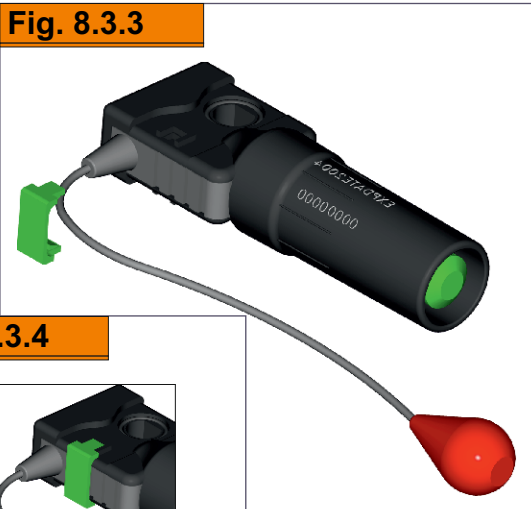

With the firing capsule fitted, fit the retaining clip. The clip is fitted by pressing it over the firing arm and in to the recess either side in the centre of the operating head. The clip will click into place, thereby preventing the arm from moving.

Fig. 8.3.4

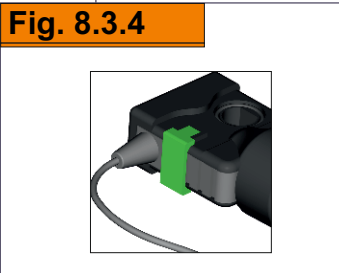

Fig 8.3 Crewsaver Mk5 Operating Head

Fig. 8.3.5



Check the bottom O-ring seal is in place. Before fitting the operating head onto the manifold, check that the Schrader valve is fitted. If fitting a new Schrader valve use a calibrated torque driver set to 0.32 - 0.36 Nm. Then place the operating head onto the manifold , so that the cylinder is pointing upwards.

Fig. 8.3.6

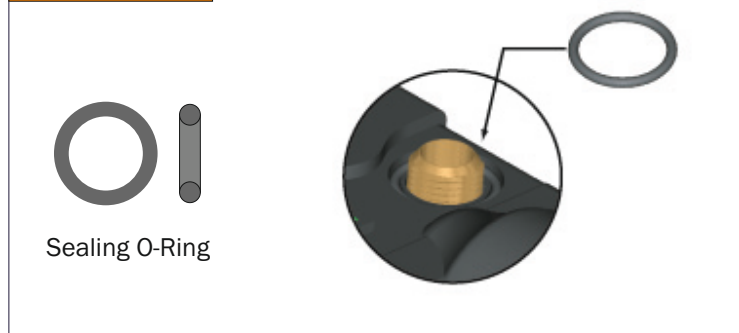

Fig. 8.3.7



Check the O-ring seal is in the recess on the top face of the operating head. With the top O-ring in place, fit the retaining nut. The retaining nut should be screwed into place using a torque wrench or driver fitted with a 9/16" socket. The wrench or driver should be set to between 2.5 and 2.7 Nm. This will prevent damage to the operating head and ensure a good seal is maintained.

Fig 8.4 Hammar Operating Head

Fig. 8.4.1

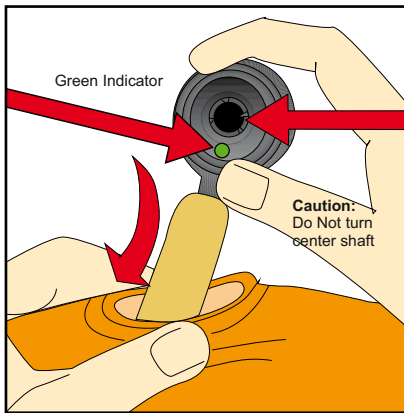

Check that the indicator is green. Insert new inflator body with gas cylinder pointing upward inside the lifejacket (PFD). Let the sealing ring rest on the inflator body around the four lugs.

Fig. 8.4.2

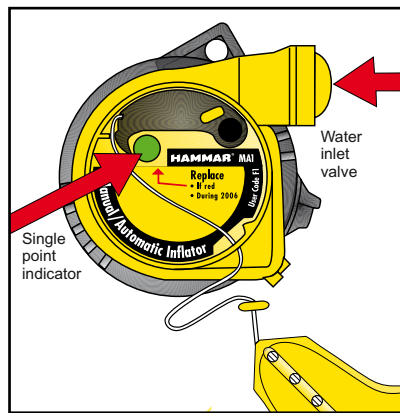

Now check the new manual/ automatic cap as follows:

1. Single point indicator showing green?
2. Expiry date OK?
If YES is the answer to both these questions, then proceed as follows.
If NO get a new cap.

Fig. 8.4.3

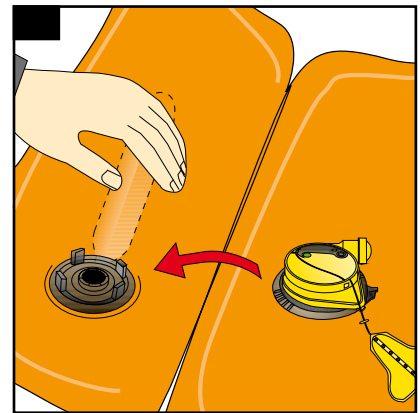

Hold the gas cylinder through the fabric of the lifejacket.

Fig. 8.4.4

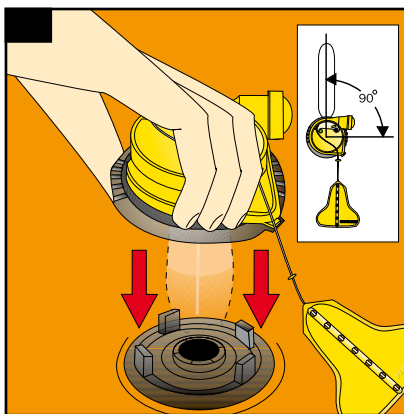

Position the replacement cap with the water inlet valve pointing to the right (7b) and press it FIRMLY onto the inflator body and sealing ring.

Fig. 8.4.5

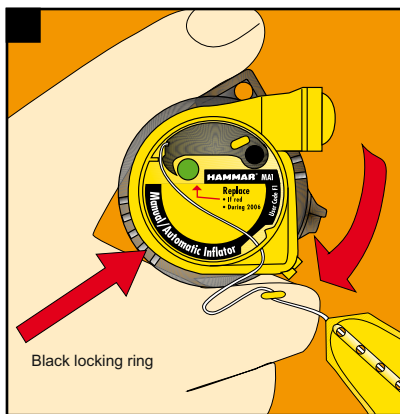

While pressing FIRMLY onto the inflator body turn the BLACK locking ring clockwise into the locked position. Pull on the cap to make sure it has locked onto the inflator body.

Please Note: The operating head may not match the images above, but the processes are always the same.

Fig 8.5 Crewfit 150 Packing Instructions

Fig. 8.5.1

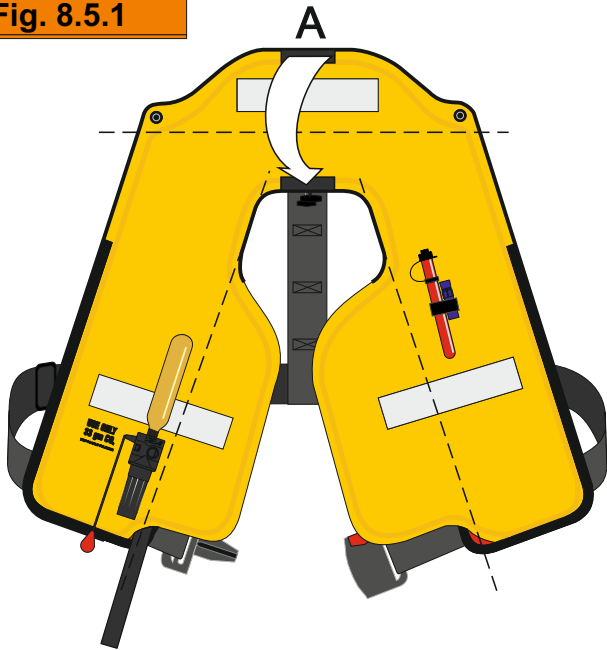

Lay Lifejacket out flat as shown in Diagram 1. Fold down the collar flap (A), line up the velcro and fasten.

Fig. 8.5.2

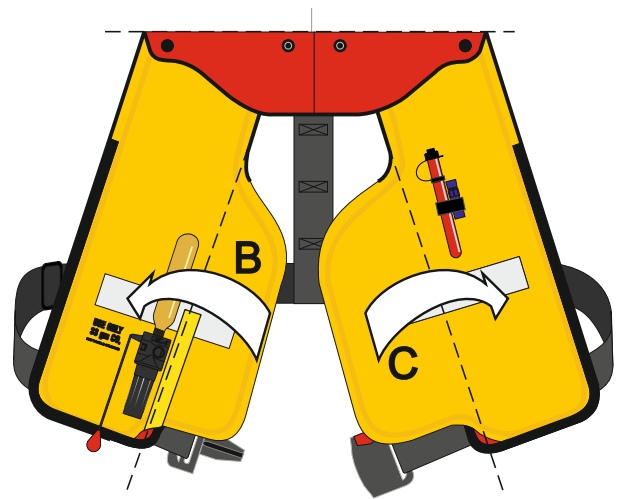

Fold lapels B and C across the front of the inflator at the dotted lines shown.

Fig. 8.5.3

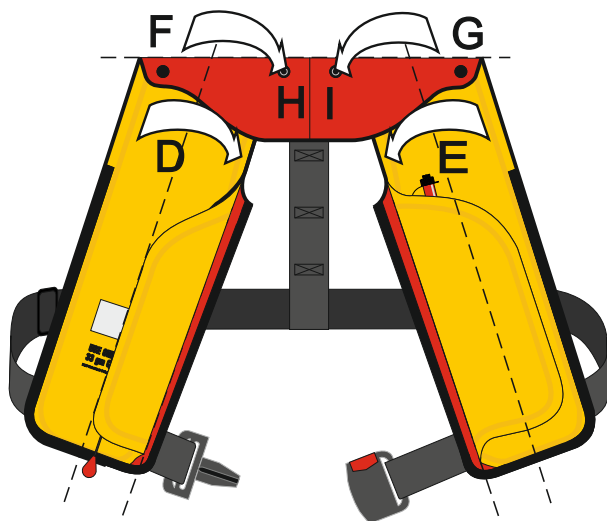

Fold sides D and E inwards and fasten the velcro. Secure the press studs at the top F onto H and G onto I.

Fig. 8.5.4



The Lifejacket is now repacked with the manual pull toggle visible.

Fig 8.6 Crewfit 150 Zipped Packing Instructions

Fig. 8.6.1



Lay Lifejacket out flat as shown in Diagram 1. Fold down the collar flap (A), line up the velcro and fasten.

Fig. 8.6.2

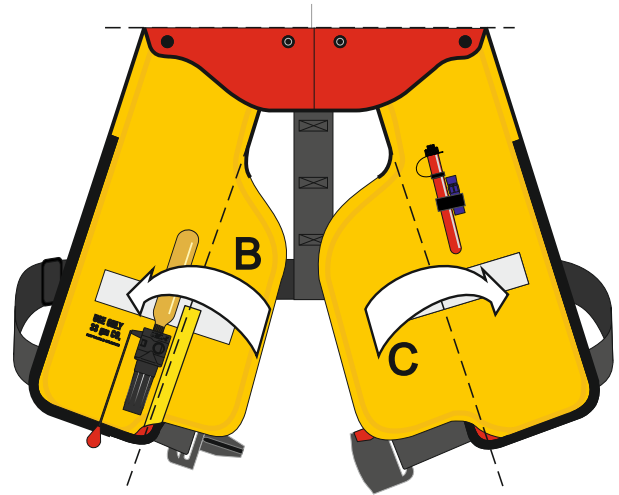

Fold lapels B and C across the front of the inflator at the dotted lines shown.

Fig. 8.6.3

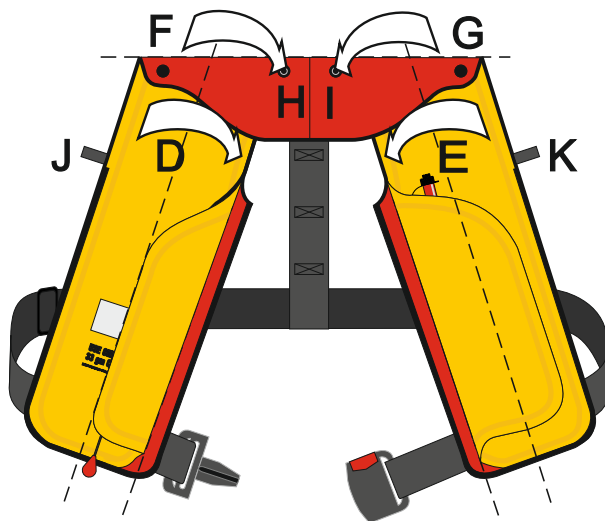

Fold sides D and E inwards, Secure the press studs at the top F onto H and G onto I. Fasten the zip by pulling the slider fully up and down again to engage the teeth. Ensure the manual pull toggle is visible. Fasten the velcro tabs J and K.

Fig. 8.6.4



The Lifejacket is now repacked with the manual pull toggle visible.

Fig 8.7 Crewfit 150 Short Packing Instructions

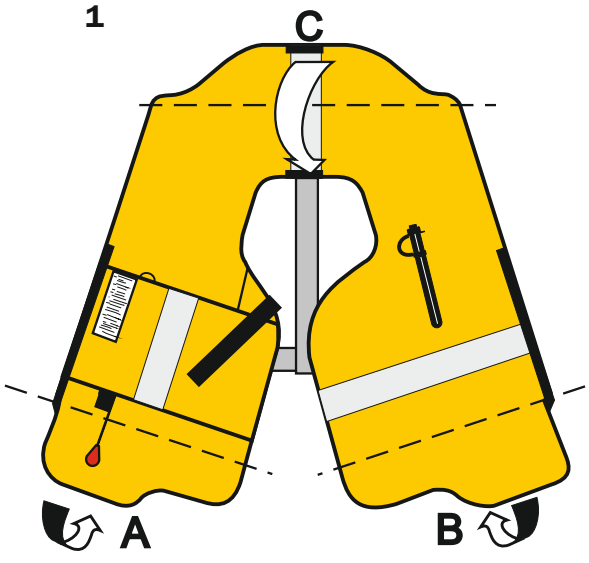
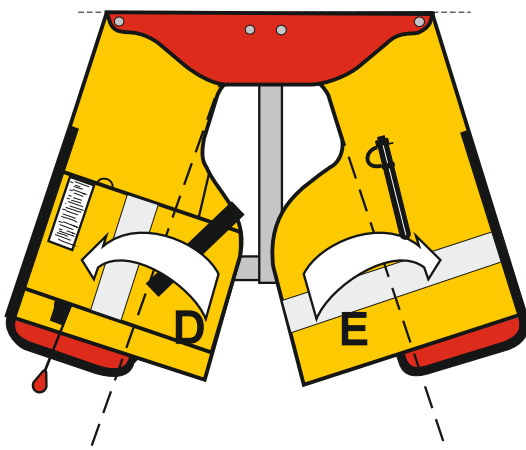
<p>1</p>  <p>Lay the jacket out as shown. Fold the bottom of the inflators A and B under and fold the collar C down and attach the velcro.</p>	<p>2</p>  <p>Fold the two inner lobes D and E in over the inflation tube and cylinder cover.</p>
--	---

<p>3</p>  <p>Fold the outer edges F and G of the inflator in towards the centre and attach the velcro along the inside edge, push together the poppers H and I onto the poppers J and K</p>	<p>4</p>  <p>The drawing above shows the correctly folded lifejacket with the manual lanyard visible and ready for use.</p>
---	--

Fig 8.8 Crewfit Junior 150 Packing Instructions

Fig. 8.8.1

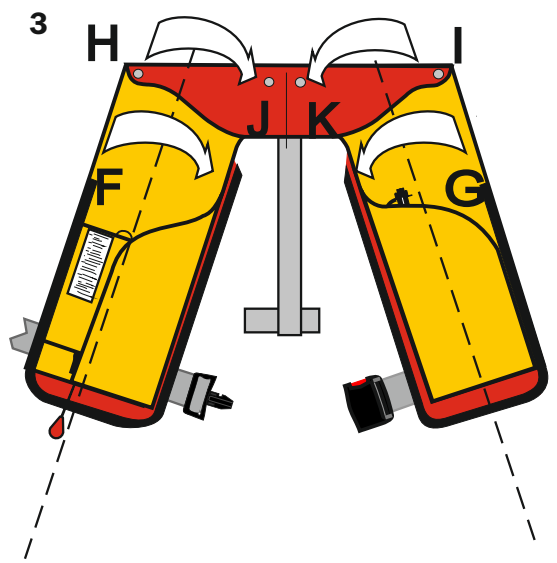
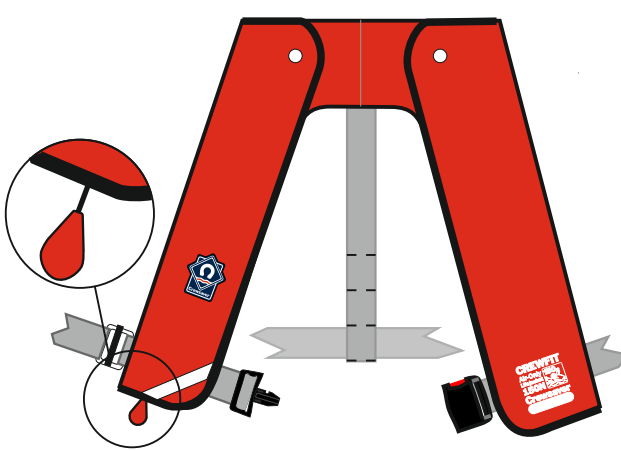
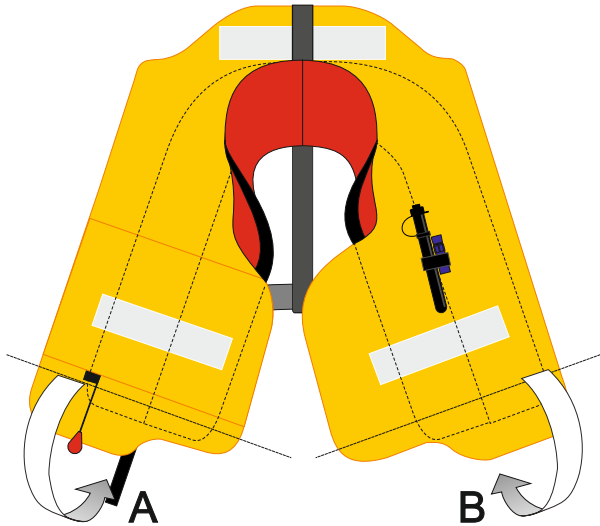

Lay Lifejacket out flat as shown in Diagram 1. Fold the bottoms of the inflator, A and B, under.

Fig. 8.8.2

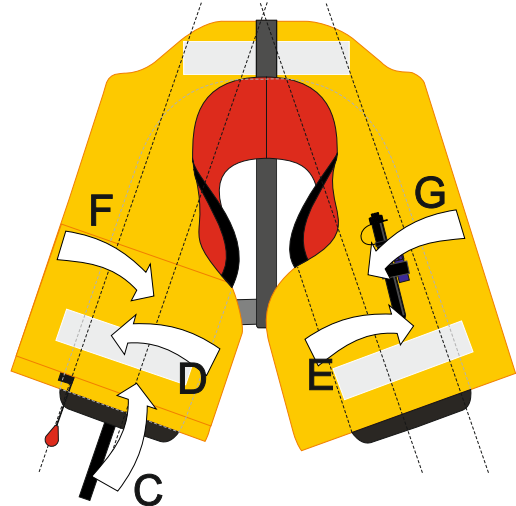

Fold the lifting becket, C, over the top of the inflator. Fold lapels D and E across the front of the inflator at the dotted lines shown. Then fold over the outside edges, F and G.

Fig. 8.8.3

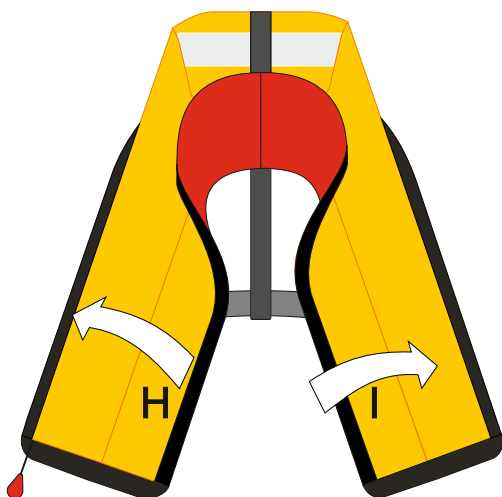

Fold over the inside edges of the cover, H and I, and fasten the velcro.

Fig. 8.8.4

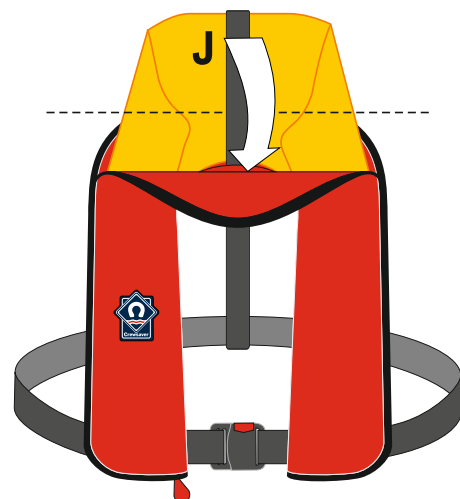

Fold the inflator, J, down below the top of the collar.

Fig 8.8 Crewfit Junior 150 Packing Instructions

Fig. 8.8.5

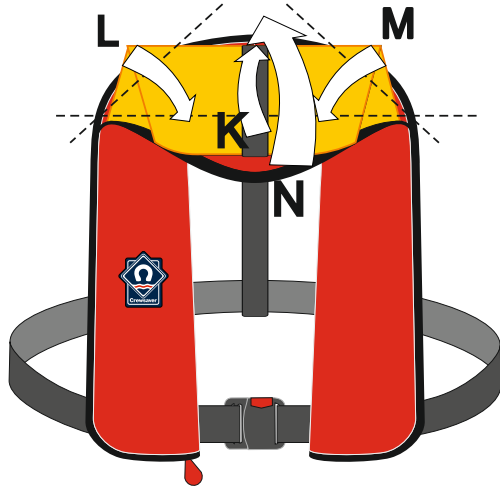

Fold the top of the inflator, K, upwards then fold the corners L and M, over diagonally and fasten the velcro around the collar.

Fig. 8.8.6



The Crewfit Junior is shown above, correctly packed with the manual pull toggle visible.

9.1 Parts List

Product Description	Part Number
33 gram CO ₂ Cylinder	12040
23 gram CO ₂ Cylinder	12020
Crewsaver Mk5i Auto Capsule	10012
Halkey Roberts Manual Head	10550
Manual Head Retaining Clip	10210
Manual Head Bottom Sealing Gasket	10096
Manual Head Top Sealing Gasket	10097
Manual Head Cylinder Sealing Gasket	10382
Crewsaver Mk5 Auto Head Retaining Clip	10111
Auto Head Sealing Gasket (Top and Bottom)	10373
Crewsaver Mk5 Auto Head Cylinder Sealing Gasket	10381
Crewfit Junior Anti-Tamper Device	R17020
UM Mk5 Auto Head (Yellow) AND Capsule	11044
UM Mk5i Auto Capsule	10017
UM Mk5 Auto Head Retaining Clip	11043
UM Mk5 Auto Head Cutter 'O' Ring	11048
Hammar Automatic Cap	11014
Hammar Back Plate with 33gm Cylinder	12070
Whistle	10677
CSL Light	10226
Crutch Straps (pair)	10032
Mouth Inflation Valve	10208
Mouth Inflation Valve Cap	10151
Schrader Valve	10049
Cover Fabric for minor repairs - Red	R76176
Cover Fabric for minor repairs - Blue	R76177
20mm Loop Velcro	R74801
20mm Hook Velcro	R74802
32mm Elastic	R74300
8 Plait Polyester Cord (White) for Whistle	R71000
8 Plait Polyester Cord (Black) for Light Cord	R71050
Venus Bonded Nylon Thread 40 Red for cover	R09020
Venus Bonded Nylon Thread 40 Blue for cover	R09050
Venus Bonded Nylon Thread 20 Black for flags	R10700
50mm Self Adhesive Retro reflective Tape	R47700
Owners Manual	R18250
Retaining Nut	11047
Venturi Vacuum System	10481
Servicing tool kit	10467
Cylinder adaptor for back pressure System	900032
Back pressure test unit	900031
Cylinder tightening tool	900030