



Crewsaver[®]
Safer By Design[®]

Newtons

290

275

190

150

Type

Buoyancy Aid

Lifejacket

Floatation

Inflatable

Foam

Combination

Chambers

Single

Twin

Harness

Fall Arrest (Optional)

Deck

Cover

Fire Retardant

Heavy Duty

Approval

SOLAS

WINDFARM LIFEJACKET

Using our years of expertise working with the renewable energy market Crewsaver introduce the Wind Farm Lifejacket, designed in conjunction with leading renewable energy operators make this jacket an easy and efficient choice for those operating on wind farms.

Unique key features purposely built within the jacket mean it is completely fit for purpose. This includes a split outer cover offering a medium weight wipe clean material providing the ultimate flexibility around the neck which is a key to making sure the lifejacket doesn't push the users helmet forward when in use. The working area of the jacket is made with a wipe clean, heavy duty material helping to maintain the longevity of the jacket.

A fleece material around the neck ensures the jacket maintains maximum comfort for the wearer, this is also easily detachable for a quick replacement when required.

Our experience working with numerous safety organisations worldwide provide unbeatable safety solutions should the wearer unexpectedly fall into the water. Inside the jacket offers exceptional turning speed and unrivalled freeboard, SOLAS approved light, whistle and reflective tape ensuring you can be located quickly, accessible lifting points located on the front of the jacket and exceptional chin support helping to keep the airways clear when in the water.

KEY FEATURES:

- Twin chamber 275N
- Split outer cover
- Hammar firing system
- Flexible neck
- ID window pocket
- Soft pull tabs helping to prevent snagging
- PLB & AIS Ready, optional Sea Marshall PLB pocket (as shown in image)



The Crewsaver industrial and commercial range has been developed over many years using only the most advanced fabrics and manufacturing processes. Continuous stringent research and development within the industry has seen Crewsaver products in use worldwide in a diverse range of commercial sectors and institutions. Designed to perform in the most arduous environments, Crewsaver has developed a range that suits all your safety needs.



REVERSE

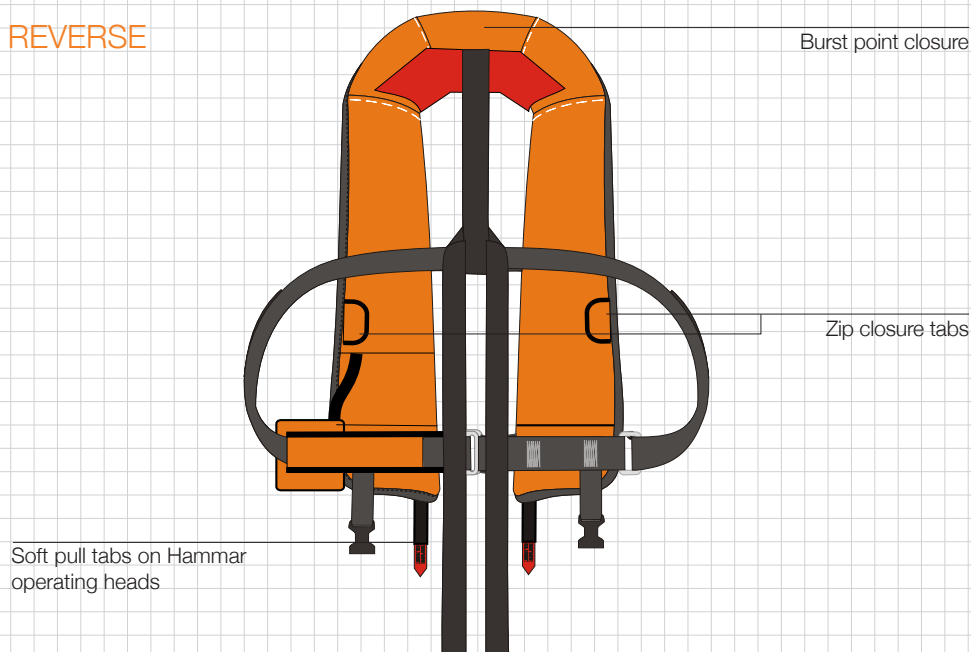

INFLATED

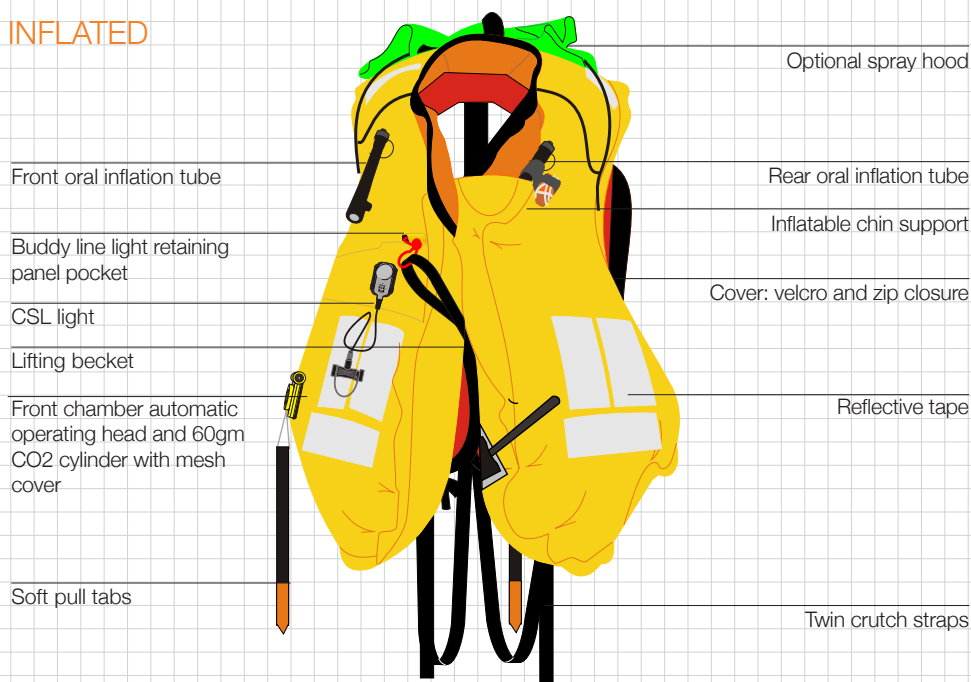

Due to Crewsaver's policy of continual improvement, we reserve the right to amend specifications where necessary without notice. Information correct at time of printing.

PART NUMBER	PRODUCT NAME
1353-WFJ	WINDFARM LIFEJACKET - AUTOMATIC
1353-WFJH	WINDFARM LIFEJACKET - AUTOMATIC WITH HOOD
1353-WFJS	SEA MARSHALL
1353-WFJSH	SEA MARSHALL - WITH HOOD

Survitec House, Lederle Lane, Gosport, Hampshire, PO13 0FZ , United Kingdom
Web: www.crewsaver.com **Email:** crewsaver.sales@survitecgroup.com

Crewsaver is a registered trademark of the Survitec Group Ltd

